

## Industrial Automation Headquarters

### Taiwan: Delta Electronics, Inc.

Taoyuan Technology Center  
No.18, Xinglong Rd., Taoyuan District,  
Taoyuan City 33068, Taiwan  
TEL: +886-3-362-6301 / FAX: +886-3-371-6301

## Asia

### China: Delta Electronics (Shanghai) Co., Ltd.

No.182 Minyu Rd., Pudong Shanghai, P.R.C.  
Post code : 201209  
TEL: +86-21-6872-3988 / FAX: +86-21-6872-3996  
Customer Service: 400-820-9595

### Japan: Delta Electronics (Japan), Inc.

Industrial Automation Sales Department  
2-1-14 Shibadaimon, Minato-ku  
Tokyo, Japan 105-0012  
TEL: +81-3-5733-1155 / FAX: +81-3-5733-1255

### Korea: Delta Electronics (Korea), Inc.

1511, 219, Gasan Digital 1-Ro., Geumcheon-gu,  
Seoul, 08501 South Korea  
TEL: +82-2-515-5305 / FAX: +82-2-515-5302

### Singapore: Delta Energy Systems (Singapore) Pte Ltd.

4 Kaki Bukit Avenue 1, #05-04, Singapore 417939  
TEL: +65-6747-5155 / FAX: +65-6744-9228

### India: Delta Electronics (India) Pvt. Ltd.

Plot No.43, Sector 35, HSIIDC Gurgaon,  
PIN 122001, Haryana, India  
TEL: +91-124-4874900 / FAX: +91-124-4874945

### Thailand: Delta Electronics (Thailand) PCL.

909 Soi 9, Moo 4, Bangpoo Industrial Estate (E.P.Z),  
Pattana 1 Rd., T.Phraksa, A.Muang,  
Samutprakarn 10280, Thailand  
TEL: +66-2709-2800 / FAX: +66-2709-2827

### Australia: Delta Electronics (Australia) Pty Ltd.

Unit 2, Building A, 18-24 Ricketts Road,  
Mount Waverley, Victoria 3149 Australia  
Mail: IA.au@deltaww.com  
TEL: +61-1300-335-823 / +61-3-9543-3720

## Americas

### USA: Delta Electronics (Americas) Ltd.

5101 Davis Drive, Research Triangle Park, NC 27709, U.S.A.  
TEL: +1-919-767-3813 / FAX: +1-919-767-3969

### Brazil: Delta Electronics Brazil Ltd.

Estrada Velha Rio-São Paulo, 5300 Eugênio de  
Melo - São José dos Campos CEP: 12247-004 - SP - Brazil  
TEL: +55-12-3932-2300 / FAX: +55-12-3932-237

### Mexico: Delta Electronics International Mexico S.A. de C.V.

Gustavo Baz No. 309 Edificio E PB 103  
Colonia La Loma, CP 54060  
Tlalnepantla, Estado de México  
TEL: +52-55-3603-9200

## EMEA

### EMEA Headquarters: Delta Electronics (Netherlands) B.V.

Sales: Sales.IA.EMEA@deltaww.com  
Marketing: Marketing.IA.EMEA@deltaww.com  
Technical Support: iatechnicalsupport@deltaww.com  
Customer Support: Customer-Support@deltaww.com  
Service: Service.IA.emea@deltaww.com  
TEL: +31(0)40 800 3900

### BENELUX: Delta Electronics (Netherlands) B.V.

Automotive Campus 260, 5708 JZ Helmond, The Netherlands  
Mail: Sales.IA.Benelux@deltaww.com  
TEL: +31(0)40 800 3900

### DACH: Delta Electronics (Netherlands) B.V.

Coesterweg 45, D-59494 Soest, Germany  
Mail: Sales.IA.DACH@deltaww.com  
TEL: +49(0)2921 987 0

### France: Delta Electronics (France) S.A.

ZI du bois Challand 2, 15 rue des Pyrénées,  
Lisses, 91090 Evry Cedex, France  
Mail: Sales.IA.FR@deltaww.com  
TEL: +33(0)1 69 77 82 60

### Iberia: Delta Electronics Solutions (Spain) S.L.U

Ctra. De Villaverde a Vallecas, 265 1º Dcha Ed.  
Hormigueras - P.I. de Vallecas 28031 Madrid  
TEL: +34(0)91 223 74 20

### Carrer Llacuna 166, 08018 Barcelona, Spain

Mail: Sales.IA.Iberia@deltaww.com

### Italy: Delta Electronics (Italy) S.r.l.

Via Meda 2-22060 Novedrate(CO)  
Piazza Grazioli 18 00186 Roma Italy  
Mail: Sales.IA.Italy@deltaww.com  
TEL: +39 039 8900365

### Russia: Delta Energy System LLC

Vereyskaya Plaza II, office 112 Vereyskaya str.  
17 121357 Moscow Russia  
Mail: Sales.IA.RU@deltaww.com  
TEL: +7 495 644 3240

### Turkey: Delta Greentech Elektronik San. Ltd. Sti. (Turkey)

Şerifali Mah. Hendem Cad. Kule Sok. No:16-A  
34775 Ümraniye - İstanbul  
Mail: Sales.IA.Turkey@deltaww.com  
TEL: + 90 216 499 9910

### MEA: Eltek Dubai (Eltek MEA DMCC)

OFFICE 2504, 25th Floor, Saba Tower 1,  
Jumeirah Lakes Towers, Dubai, UAE  
Mail: Sales.IA.MEA@deltaww.com  
TEL: +971(0)4 2690148



Digitized Automation for a Changing World

# AH Motion Controller Operation Manual

# AH Motion Controller Operation Manual

## Revision History

Version	Revision	Date
1 <sup>st</sup>	The first version was published.	2017/09/20
2 <sup>nd</sup>	<ol style="list-style-type: none"> <li>1. Correct C0, C1, C2, C3 to COM on the diagrams depicting transistor output circuits in section 2.2.3.2</li> <li>2. Add CPU module parameter settings in Chapter 4.</li> <li>3. Add EtherCAT symbols; delete AR and AM device in Chapter 5.</li> <li>4. Revise motion axes parameter description; delete un-used motion axes parameters in Chapter 6.</li> <li>5. Revise axis states and state transitions; add BufferMode function in Chapter 7.</li> <li>6. Add memory card FTP description in Chapter 8.</li> <li>7. Revise error codes indicators and troubleshooting; delete AR and AM device in Chapter 9.</li> </ol>	2018/08/31
3 <sup>rd</sup>	<ol style="list-style-type: none"> <li>1. Add information of applicable barometric pressure and equivalent altitude, silicone flammability rating, weight, isolated communication ports and isolated digital inputs/outputs to the specification in chapter 1.4.</li> <li>2. Add error codes: 16#0025, 16#005D, 16#0060, 16#1400, 16#1407, 16#1409, 16#140A, 16#340E, 16#3422, 16#3429-16#342E, 16#343C-16#343E, 16#3464-16#3482, 16#3515-16#351B, 16#3522, 16#3530-16#355E, 16#3627, 16#3632-16#3634, 16#3640, 16#3700-16#3744, 16#3770-16#3784, 16#3802, 16#3803, 16#3908, 16#390E, 16#3956-16#3962, 16#3A30, 16#3C00, 16#3D05, 16#3E00-16#3E18, 16#4001-16#4100, 16#600B, 16#600C, 16#600E, 16#6100-16#620C, 16#620E-16#6211, 16#6215-16#630B, 16#6500, 16#6600-16#6606, 16#7204, 16#7404-16#7406, 16#7411, 16#8114, 16#8241, 16#9A61-16#9A64, 16#A010-16#A808 and other related information ; Update error codes 16#005E, 16#005F, 16#0061-16#0065, 16#1801, 16#3400-16#3404, 16#3414, 16#3415, 16#3635-16#3639, 16#8242-16#8247.</li> </ol>	2023/5/10



# AH Motion Controller Operation Manual

## Contents

### Preface

<b>P.1</b>	<b>Introduction .....</b>	<b>II</b>
P.1.1	Applicable Products .....	II
P.1.2	Related Manuals .....	II
<b>P.2</b>	<b>Navigation between Manuals.....</b>	<b>III</b>

### Chapter 1 Introduction to Motion Control Operation

<b>1.1</b>	<b>Features of AH Motion .....</b>	<b>1-2</b>
1.1.1.	PLCopen based Motion Control Instructions.....	1-2
1.1.2.	Motion Network Communications.....	1-2
<b>1.2</b>	<b>AH Motion System Configurations.....</b>	<b>1-3</b>
<b>1.3</b>	<b>Basic Operating Procedures for Motion Control .....</b>	<b>1-4</b>
<b>1.4</b>	<b>Specifications of AH Motion CPU.....</b>	<b>1-6</b>
1.4.1	General Specifications.....	1-6
1.4.2	Motion Control Specifications .....	1-10

### Chapter 2 Hardware Setup

<b>2.1</b>	<b>Installation.....</b>	<b>2-2</b>
2.1.1	CPU Rack Installation in a Control Panel .....	2-2
2.1.2	Mounting a Backplane.....	2-2
2.1.3	Installing a CPU/Module .....	2-4
<b>2.2</b>	<b>Wiring.....</b>	<b>2-6</b>
2.2.1	Basic System Configurations.....	2-6
2.2.2	Wiring Power Supply Modules.....	2-6
2.2.3	Wiring AH Motion CPU Modules.....	2-12

### Chapter 3 Software Setup

<b>3.1</b>	<b>Installing and Uninstalling ISPSOft.....</b>	<b>3-2</b>
3.1.1	Installing ISPSOft .....	3-3
3.1.2	Uninstalling ISPSOft.....	3-6



<b>3.2</b>	<b>Installing and Uninstalling COMMGR .....</b>	<b>3-8</b>
3.2.1	Installing COMMGR .....	3-8
3.2.2	Uninstalling COMMGR .....	3-10
<b>3.3</b>	<b>Connecting ISPSOft with AH Motion CPU .....</b>	<b>3-12</b>
3.3.1	Direct connection via USB .....	3-12
3.3.2	Direct connection via Ethernet .....	3-12

## **Chapter 4 Operating ISPSOft**

<b>4.1</b>	<b>Quick Start .....</b>	<b>4-2</b>
4.1.1	Example .....	4-2
4.1.2	Hardware .....	4-2
4.1.3	Program .....	4-3
<b>4.2</b>	<b>Procedures for Creating a Project in ISPSOft .....</b>	<b>4-3</b>
<b>4.3</b>	<b>Creating a Project.....</b>	<b>4-4</b>
<b>4.4</b>	<b>Hardware Configuration .....</b>	<b>4-5</b>
4.4.1	Configuring a Module.....	4-5
4.4.2	Setting the Parameters in a CPU and a Module.....	4-7
4.4.3	Setting Module Parameters .....	4-9
4.4.4	Setting PLC Parameters .....	4-16
<b>4.5</b>	<b>Creating a Program .....</b>	<b>4-18</b>
4.5.1	Adding a Ladder Diagram.....	4-19
4.5.2	Basic Editing—Creating a Contact and a Coil .....	4-21
4.5.3	Basic Editing—Inserting a Network and Typing an Instruction .....	4-24
4.5.4	Basic Editing - Selection of a Network and Operation .....	4-26
4.5.5	Basic Editing - Connecting a Contact in Parallel .....	4-28
4.5.6	Basic Editing—Editing a Comment.....	4-29
4.5.7	Basic Editing—Inserting an Applied Instruction.....	4-30
4.5.8	Basic Editing—Creating a Comparison Contact and Typing a Constant ..	4-32
4.5.9	Writing a Program.....	4-33
4.5.10	Checking and Compiling a Program .....	4-34
<b>4.6</b>	<b>Testing and Debugging a Program.....</b>	<b>4-35</b>
4.6.1	Creating a Connection .....	4-35
4.6.2	Downloading a Program and Parameters .....	4-38
4.6.3	Connection Test.....	4-40

4.6.4	Setting a Real-time Clock .....	4-46
-------	---------------------------------	------

## **Chapter 5 Understanding Common Devices**

<b>5.1.</b>	<b>Introduction .....</b>	<b>5-2</b>
<b>5.2.</b>	<b>Common Devices .....</b>	<b>5-2</b>
5.2.1.	Functions of Common Devices.....	5-2
5.2.2.	Device List .....	5-2
5.2.3.	Latched Devices.....	5-4
5.2.4.	Input Relays (X) .....	5-5
5.2.5.	Output Relays (Y) .....	5-5
5.2.6.	Auxiliary Relays (M) .....	5-6
5.2.7.	Special Auxiliary Relays (SM/AM) .....	5-6
5.2.8.	Data Registers (D) .....	5-6
5.2.9.	Special Data Registers (SR/AR) .....	5-7
5.2.10.	Link Registers (L).....	5-7
5.2.11.	Stepping Relays (S).....	5-7
5.2.12.	Timers (T).....	5-7
5.2.13.	Counters (C) .....	5-9
5.2.14.	32-bit Counters (HC/AC) .....	5-10
5.2.15.	Index Registers (E) .....	5-10
5.2.16.	Values and Constants (K, 16#) .....	5-11
5.2.17.	Floating-point Numbers (F, DF) .....	5-12
5.2.18.	Strings (“\$”).....	5-14
<b>5.3.</b>	<b>EtherCAT Symbols .....</b>	<b>5-16</b>
<b>5.4.</b>	<b>Symbols.....</b>	<b>5-16</b>
5.4.1	Application of Symbols.....	5-16
5.4.2	Classes.....	5-16
5.4.3	Data Types.....	5-17
5.4.4	Using Devices, Symbols and Instructions .....	5-18
5.4.5	Modifying a Symbol with an Index Register .....	5-19
<b>5.5.</b>	<b>User-defined Data Type (ENUM).....</b>	<b>5-20</b>

## **Chapter 6 Understanding Motion Control Devices**

<b>6.1</b>	<b>Motion Control Devices.....</b>	<b>6-2</b>
------------	------------------------------------	------------

6.1.1.	Structures Applicable for Motion Control.....	6-2
6.1.2.	Parameters for Motion Axes.....	6-2

## Chapter 7 Motion Control Programming

<b>7.1</b>	<b>Introduction.....</b>	<b>7-2</b>
7.1.1	Program Organization Units and Tasks .....	7-2
<b>7.2</b>	<b>Motion Control Program .....</b>	<b>7-3</b>
7.2.1	Program Architecture and Types in ISPSOft .....	7-3
7.2.2	POUs in ISPSOft .....	7-4
7.2.3	Managing the Tasks in ISPSOft .....	7-4
<b>7.3</b>	<b>Motion Control Instructions .....</b>	<b>7-5</b>
7.3.1	Function Blocks for AH Motion Controller CPU.....	7-5
<b>7.4</b>	<b>Axis.....</b>	<b>7-7</b>
<b>7.5</b>	<b>State Transitions.....</b>	<b>7-10</b>
7.5.1	Axis States.....	7-10
7.5.2	Axis Group State.....	7-11
<b>7.6</b>	<b>Buffer Mode .....</b>	<b>7-12</b>
<b>7.7</b>	<b>Execution of Function Block Instructions .....</b>	<b>7-17</b>
7.7.1	The Interface of a Motion Control Function Block .....	7-17
7.7.2	Timing Diagram for Input/Outputs .....	7-20
<b>7.8</b>	<b>Positions .....</b>	<b>7-21</b>
7.8.1	Position Types .....	7-21
7.8.2	Applicable Positions for Each Axis Type .....	7-21
<b>7.9</b>	<b>Electronic Cam.....</b>	<b>7-21</b>
7.9.1	Introduction of Electronic Cams.....	7-21
7.9.2	Operation of an Electronic Cam .....	7-22
7.9.3	Creating Electronic Cam Data .....	7-31
7.9.4	Application of an Electronic Cam—Using a Rotary Cutter.....	7-40

## Chapter 8 Memory Card

<b>8.1</b>	<b>Overview of Memory Cards .....</b>	<b>8-2</b>
8.1.1	Appearances of Memory Cards.....	8-2

8.1.2	Specifications for SD Cards .....	8-2
<b>8.2</b>	<b>Using a Memory Card .....</b>	<b>8-3</b>
8.2.1.	Formatting a Memory Card .....	8-3
<b>8.3</b>	<b>Installing and Removing a Memory Card .....</b>	<b>8-5</b>
8.3.1.	SD Slot in a CPU .....	8-5
8.3.2.	Installing a Memory Card .....	8-6
8.3.3.	Removing a Memory Card .....	8-6
<b>8.4</b>	<b>Contents of a Memory Card .....</b>	<b>8-7</b>
8.4.1.	Initializing a Memory Card .....	8-7
8.4.2.	Folder Structure in a Memory Card .....	8-7
<b>8.5</b>	<b>Reading/Writing a Memory Card .....</b>	<b>8-8</b>
8.5.1.	Backing up the System .....	8-8
8.5.2.	Restoring the System .....	8-8
<b>8.6</b>	<b>CARD Utility.....</b>	<b>8-8</b>
<b>8.7</b>	<b>Backup .....</b>	<b>8-10</b>
<b>8.8</b>	<b>Restoration .....</b>	<b>8-14</b>

## Chapter 9 Troubleshooting

<b>9.1</b>	<b>Inspection and Troubleshooting.....</b>	<b>9-3</b>
9.1.1.	Basic Inspection.....	9-3
9.1.2.	Clearing the Error State .....	9-3
9.1.3.	Troubleshooting Procedure.....	9-4
9.1.4.	Viewing Error Logs .....	9-5
<b>9.2</b>	<b>Error Codes and Indicators.....</b>	<b>9-6</b>
9.2.1.	AHxxEMC-5A .....	9-7
9.2.2.	Analog I/O Modules and Temperature Measurement Modules.....	9-39
9.2.3.	AH02HC-5A/AH04HC-5A .....	9-41
9.2.4.	AH05PM-5A/AH10PM-5A/AH15PM-5A .....	9-41
9.2.5.	AH20MC-5A.....	9-43
9.2.6.	AH10EN-5A/AH15EN-5A.....	9-44
9.2.7.	AH10SCM-5A/AH15SCM-5A .....	9-44
9.2.8.	AH10DNET-5A .....	9-44
9.2.9.	AH10PFBM-5A .....	9-45

9.2.10.	AH10PFBS-5A .....	9-45
9.2.11.	AH10COPM-5A .....	9-46
<b>9.3</b>	<b>Troubleshooting for CPU .....</b>	<b>9-47</b>
9.3.1.	ERROR Indicator ON.....	9-47
9.3.2.	ERROR Indicator Blinking .....	9-49
9.3.3.	BUS FAULT Indicator ON .....	9-92
9.3.4.	BUS FAULT Indicator Blinking.....	9-94
9.3.5.	Others .....	9-102
<b>9.4</b>	<b>Troubleshooting for I/O Modules .....</b>	<b>9-114</b>
9.4.1.	Analog I/O Modules and Temperature Measurement Modules.....	9-114
9.4.2.	AH02HC-5A/AH04HC-5A .....	9-116
9.4.3.	AH05PM-5A/AH10PM-5A/AH15PM-5A.....	9-118
9.4.4.	AH20MC-5A .....	9-121
9.4.5.	AH10EN-5A/AH15EN-5A .....	9-122
9.4.6.	AH10SCM-5A/AH15SCM-5A.....	9-123
9.4.7.	AH10DNET-5A .....	9-123
9.4.8.	AH10PFBM-5A .....	9-124
9.4.9.	AH10PFBS-5A .....	9-125
9.4.10.	AH10COPM-5A .....	9-125
<b>9.5</b>	<b>Troubleshooting for Limitation Errors .....</b>	<b>9-127</b>
9.5.1.	Software limit errors .....	9-127
9.5.2.	Hardware limit errors .....	9-128

## Appendices

<b>A.1</b>	<b>Installing the USB Driver for an AH Motion CPU on Windows 7 .....</b>	<b>A-2</b>
<b>A.2</b>	<b>Device Addresses .....</b>	<b>A-5</b>
<b>A.3</b>	<b>Operating Principles of the CPU Module .....</b>	<b>A-7</b>
A.3.1	Operation of the CPU Module.....	A-7
A.3.2	Operating Modes of the CPU Module .....	A-9





---

# Preface

## Table of Contents

<b>P.1</b>	<b>Introduction .....</b>	<b>II</b>
P.1.1	Applicable Products .....	II
P.1.2	Related Manuals .....	II
<b>P.2</b>	<b>Navigation between Manuals.....</b>	<b>III</b>

## P.1 Introduction

Thank you for purchasing the AH series Motion Controller CPU with our advanced motion control system.

This manual introduces the concept of motion control operation, overview of software operation, motion control programming procedures, and troubleshooting information of the system. Please ensure that you understand the configuration and operations of the AH series motion control system, and use the AH series motion controller CPU correctly.

To obtain required information for different system configurations, you can navigate between different manuals of AH Motion Controller series manuals and other related manuals.

### P.1.1 Applicable Products

This manual relates to the following products

- AHxxEMC-5A (AH08EMC-5A/AH10EMC-5A/AH20EMC-5A)
- AH500 series modules

### P.1.2 Related Manuals

The related manuals of the AH Motion series motion controllers are composed of the following.

#### 1. AH Motion Controller - Hardware Manual

It introduces function specifications, electrical specifications, appearances, dimensions, and etc.

#### 2. ISPSOFT User Manual

It introduces the use of ISPSOFT, the programming languages (ladder diagrams, instruction lists, sequential function charts, function block diagrams, and structured texts), the concept of POU, the concept of tasks, and the operation of motion control programming.

#### 3. AH Motion Controller - Standard Instructions Manual

It introduces the elements for standard programming including devices, symbols and standard instructions.

#### 4. AH Motion Controller - Operation Manual

It introduces basic knowledge of motion control structure, software/hardware setup, quick start of software operations, devices to be used, motion control operations and troubleshooting.

#### 5. AH Motion Controller - Motion Control Instructions Manual

It introduces the elements for motion control programming including axis parameters, symbols and single axis/multi-axes motion instructions.

#### 6. AH500 Motion Control Module Manual

It introduces the specifications for the AH500 series motion control modules, the wiring, the instructions, and the functions.

#### 7. AH500 Module Manual

It introduces the use of special I/O modules of AH500 series PLCs. For example, network modules, analog I/O modules, temperature measurement modules, and etc.

## P.2 Navigation between Manuals

Before using the products, there are three manuals that should be utilized as fundamental information: **AH Motion Controller - Hardware Manual**, **ISPSOft User Manual**, and **AH Motion Controller - Standard Instructions Manual**.

With the fundamental manuals, you can understand the basic information of hardware configuration, operation procedures of the software, and the basic instructions for using the system.

To obtain required information for different system configurations and applications, refer to other manuals as indicated in the table below. Reading all manuals related to your system configuration helps you make the most use of the AH series motion control system.

Related manuals		AH Motion Controller series manuals						
		Fundamental			AH Motion Controller – Operation Manual	AH Motion Controller – Motion Control Instructions Manual	AH500 Motion Control Module Manual	AH500 Module Manual
		AH Motion Controller – Hardware Manual	ISPSOft User Manual	AH Motion Controller – Standard Instructions Manual				
General operation procedures								
1. Overview of AH Motion Controller series products		V						
2. Setting up hardware configuration for the system		V						
	for motion control applications				V			
	for communication (e.g. EtherCAT)							
	for additional motion control modules					V		
	for I/O extension using AH500 series modules						V	
3. Getting started with the software		V						
	for motion control applications				V			
	for communication (e.g. EtherCAT)							
	for additional motion control modules					V		
	for I/O extension using AH500 series modules						V	
4. Programming		V		V				
	for motion control applications				V	V		
	for communication (e.g. EtherCAT)							
	for additional motion control modules						V	

P

Related manuals		AH Motion Controller series manuals						
		Fundamental			AH Motion Controller – Operation Manual	AH Motion Controller – Motion Control Instructions Manual	AH500 Motion Control Module Manual	AH500 Module Manual
		AH Motion Controller – Hardware Manual	ISPSOFT User Manual	AH Motion Controller – Standard Instructions Manual				
General operation procedures								
	for I/O extension using AH500 series modules						V	
5. Testing and troubleshooting								
	for motion control applications				V*			
	for communication (e.g. EtherCAT)		V					
	for additional motion control modules			V*		V		
	for I/O extension using AH500 series modules			V*			V	
6. Maintenance and Inspection		V						

**\*Note:** Information regarding Error codes and Indicators and the associate troubleshooting information are attached as Appendices for a quick reference. For the complete troubleshooting of the system, refer to **AH Motion Controller – Operation Manual**.

---

# Chapter 1 Introduction to Motion Control Operation

## Table of Contents

- 1.1 Features of AH Motion ..... 1-2**
  - 1.1.1. PLCopen based Motion Control Instructions ..... 1-2
  - 1.1.2. Motion Network Communications ..... 1-2
- 1.2 AH Motion System Configurations ..... 1-3**
- 1.3 Basic Operating Procedures for Motion Control ..... 1-4**
- 1.4 Specifications of AH Motion CPU ..... 1-6**
  - 1.4.1 General Specifications ..... 1-6
  - 1.4.2 Motion Control Specifications ..... 1-8



## 1.1 Features of AH Motion

AH Motion Controller is the advanced motion control series with dedicated motion control CPUs and shares the same modules with AH series PLCs. Through the motion control network, such as EtherCAT, AH Motion Controller CPU can perform high-speed, high-precision machine control with the connected servo drives on the motion network.

### 1.1.1. PLCopen based Motion Control Instructions

AH Motion Controller CPUs offers motion control instructions that are standardized by PLCopen\*. In addition, you can also use the convenient function block instructions developed by Delta together with the PLCopen based instructions to optimize the control flexibility. These instructions help you achieve single-axis motion, multi-axis interpolation, G-code programming, synchronized motion (e.g. electronic cam/gear), velocity control, and torque control. You can specify the motion parameters in the motion control instructions and the axis parameters according to the application.

**\*Note:**

PLCopen is an organization promoting industrial control based on IEC61131-3, which is an international standard widely adopted for PLC programming. For more information regarding PLCopen, check the official website at: <http://www.plcopen.org/>

### 1.1.2. Motion Network Communications

The AH Motion Controller CPU with built-in motion network (e.g. EtherCAT) port can be connected with Delta servo drives that supports the same motion network to perform data exchange of all control information via high-speed communications. In comparison with the traditional pulse-type motion controllers, the motion control instructions in network-type controllers are sent via data communications, meaning the servo motors performance is optimized and is not limited by the interface specifications, e.g. the response frequency of the feedback from encoders. The motion network communications allows users to achieve a real-time control and monitoring system.

## 1.2 AH Motion System Configurations

The AH Motion Controller series CPU basic configurations include the **AH Motion Controller CPU Network Configuration**, **AH500 Series Module Configuration**, and **Supported Software**.

### AH Motion Controller Network Configuration

- AHxxEMC-5A

You can use the EtherCAT master port built in on the CPU interface to connect to slave devices such as analog and digital I/O, servo drives, AC motor drives and encoder input devices. With EtherCAT network configuration, you can design a system capable of performing very accurate sequence and motion control in a fixed cycle.

### AH500 Series Module Configuration

With the motion backplane, you can also add AH500 series I/O modules\* in addition to the EtherCAT network. AH500 series modules can be installed directly to the motion backplane where the CPU module is mounted.

\*Note: a few of AH500 series I/O modules are not supported by the motion backplane. Refer to **Ch2 System Configuration** for the list of supported products.

### Supported Software

ISPSOft is the major programming software that you use for an AH Motion Controller series. You can connect the software on the computer to the USB interface on the CPU module through a commercially available USB cable. You can also connect ISPSOft to the Ethernet port on the CPU module with an Ethernet cable or to the built-in RS-485 port on the Motion backplane with a RS-485 cable and a converting device, e.g. IFD6500 USB/RS-485 converter. In addition to ISPSOft, you can also use other software for configuring various applications based on different networks.

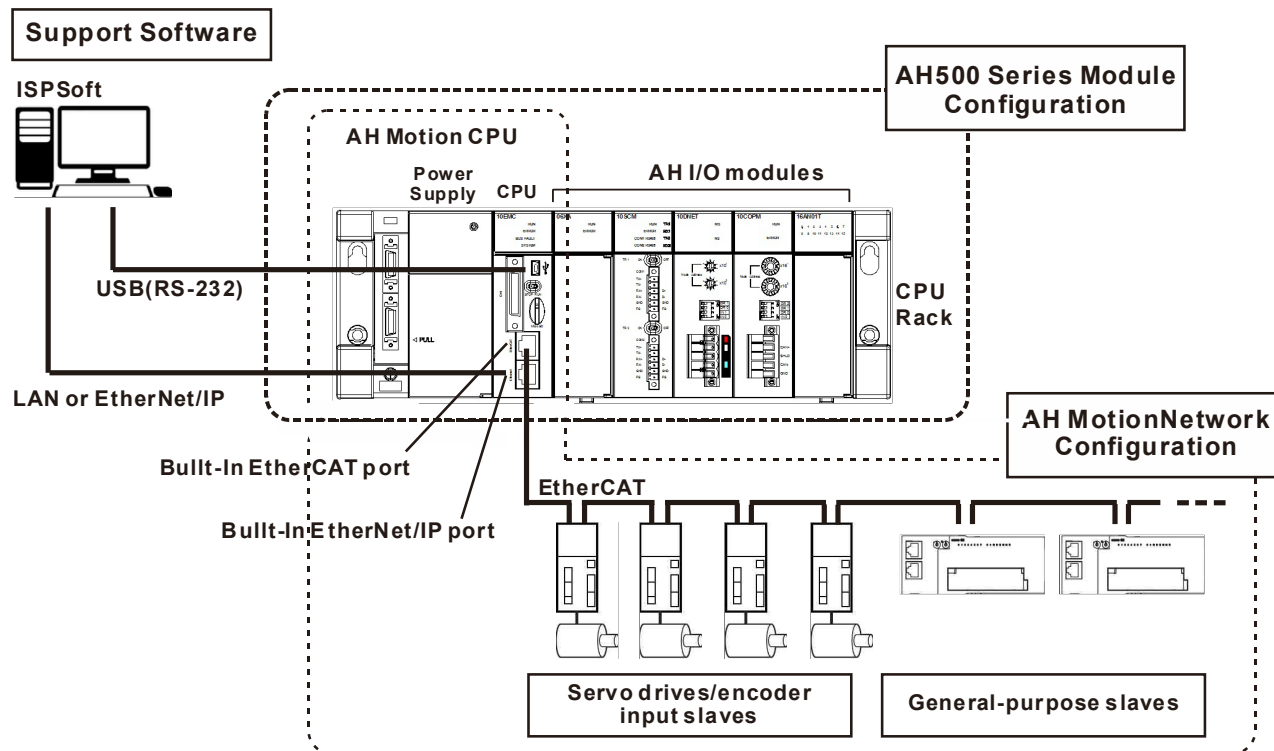

### 1.3 Basic Operating Procedures for Motion Control

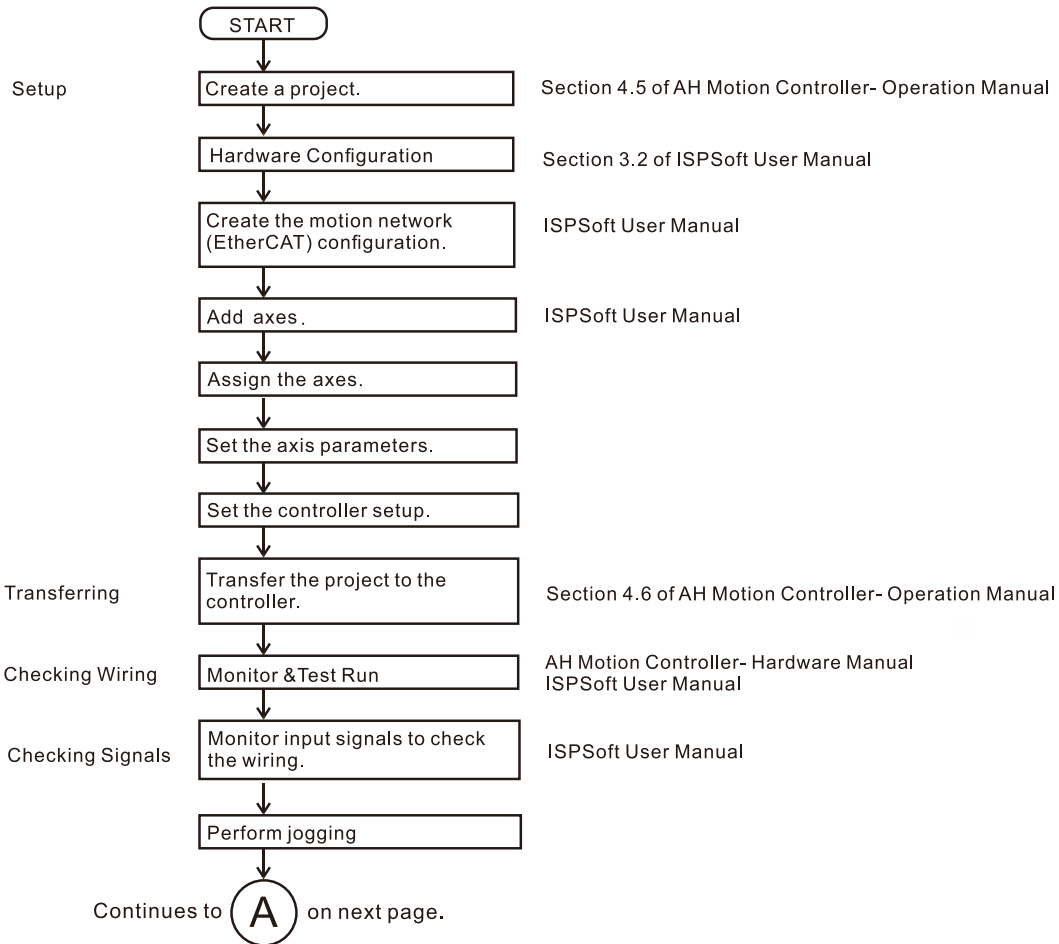

1

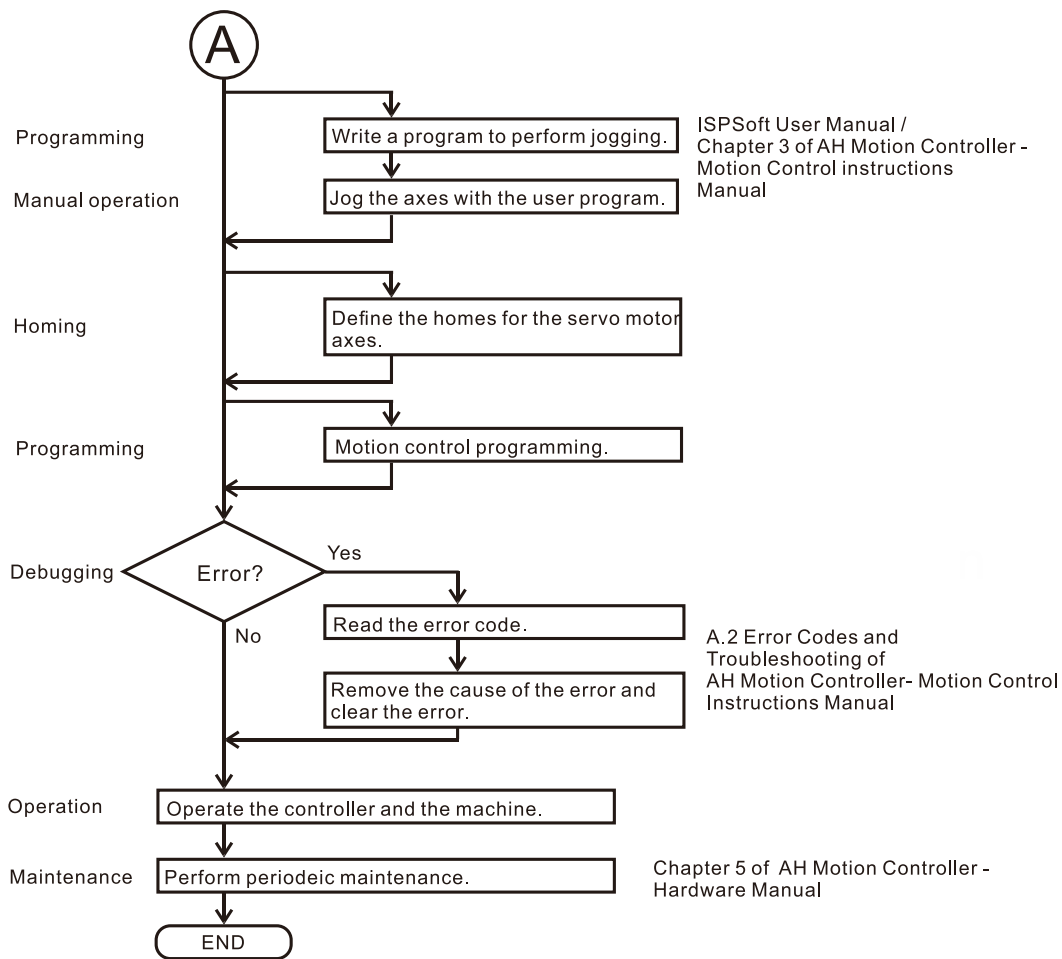

## 1.4 Specifications of AH Motion CPU

### 1.4.1 General Specifications

- AHxxEMC-5A

Environmental Specifications	
Operating temperature	-20~60°C
Storage temperature	-40~70°C
Operating humidity	5~95% No condensation
Storage humidity	5~95% No condensation
Vibration/Shock resistance	International standards IEC 61131-2, IEC 68-2-6 (TEST Fc)/ IEC 61131-2 & IEC 68-2-27 (TEST Ea)
Operating environment	No corrosive gas exists.
Installation location	In a control box
Applicable barometric pressure and equivalent altitude	Operating: 1013 ~ 795hPa (0 ~ 2000 meters) Storage: 1013 ~ 700hPa (0 ~ 3000 meters)
Pollution degree	2
Silicone Flammability Rating	UL94V-0

General Specifications		Remark
Execution	The program is executed cyclically.	
Input/Output control	Cyclically refreshed inputs/outputs Direct inputs/outputs	The inputs and outputs can be controlled through the direct inputs (DX device) and direct outputs (DY device).
Programming language	IEC 61131-3	
	Ladder diagram (LD), continuous function chart (CFC), structured text (ST), and sequential function chart (SFC).	
Instruction execution speed	0.3 ms/K steps	
Constant scan cycle (ms)	1-32000 (The scan cycle can be increased by one millisecond.)	The scan cycle time can be specified by parameters.
Program capacity (step)	256K steps	
Installation	DIN rails or screws	
Installation of modules	Modules are installed directly on a backplane.	



General Specifications		Remark
Number of modules	Five input/output modules at most can be installed on a motion backplane.	
Number of tasks	283 tasks (32 cyclic tasks, 32 I/O interrupt tasks, 212 external interrupt tasks, 1 24V LV detection, 4 timed interrupt tasks, and 2 communication interrupt tasks).	
Number of input/output devices	X/Y devices (bit): 8192 (X0.0~X511.15/Y0.0~Y511.15) X/Y devices (word): 512 (X0~X511/Y0~Y511)	Number of devices which can be used in a program
Number of inputs/outputs	328 inputs/ 324 outputs (AHxxEMC)	Number of inputs/outputs accessible to an CPU
Input relay [X]	8192 (X0.0~X511.15)	
Output relay [Y]	8192 (Y0.0~Y511.15)	
Auxiliary relay [M]	8192 (M0~M8191)	
Timer [T]	2048 (T0~T2047)	
Counter [C]	2048 (C0~C2047)	
32-bit counter [HC/AC]	HC: 64 (HC0~HC63) AC: 56 (AC0~ AC55) (AHxxEMC)	
Data register [D]	D device (bit): 1048576 (D0.0~D65535.15) D device (word): 65536 (D0~D65535)	
Stepping relay [S]	2048 (S0~S2047)	
Index register [E]	32 (E0~E31)	
Special auxiliary relay [SM]	SM: 2048 (SM0~SM2047)	
Special data register [SR]	SR: 2048 (SR0~SR2047)	
Serial communication port	One RS-232(USB), One RS-485 communication port	
Ethernet port	10/100 M	
USB port	Mini USB	
Memory card slot	Supports Micro SD card (SD 2.0)	
Real-time clock	Years, months, days, hours, minutes, seconds, and weeks	The function is available when the CPU is used together with the motion backplane
Weight	230g	
Isolated communication ports	USB/ COM - isolation voltage 500VAC Ethernet - isolation voltage 1500VAC	
Isolated digital Inputs/Outputs	Digital IO- isolation voltage 500VAC	

## 1.4.2 Motion Control Specifications

- AHxxEMC-5A

Specifications		AHxxEMC-5A
<b>Number of substantial axes supported</b>		AH08EMC: 8 axes / AH10EMC: 16 axes / AH20EMC: 32 axes (Axis 1~axis 32)
<b>Storage</b>		The capacity of the built-in storage is 256K steps.
<b>Unit</b>		Motor unit and mechanical unit
<b>Motor control</b>		EtherCAT high-speed motion control system The response time is 100 Mbps.
<b>Maximum speed</b>		EtherCAT: 100M bps Differential input: 1 MHz Open collector input: 200 KHz Open collector output: 200 KHz
<b>Input signal</b>	<b>Operating switch</b>	RUN-STOP switch
	<b>Input terminal</b>	X0.0+, X0.0-, X0.1+, X0.1-, X0.8+, X0.8-, X0.9+, X0.9-, X0.10+, X0.10-, X0.11+, X0.11-; X0.2, X0.3, X0.12, X0.13, X0.14, X0.15, X1.0, X1.1, X1.2, X1.3, X1.4, X1.5
<b>Output signal</b>	<b>Output terminal</b>	Y0.8, Y0.9, Y0.10, and Y0.11
	<b>External communication port</b>	Mini USB port Ethernet port EtherCAT port
<b>Memory card slot</b>		Supports Micro SD card The maximum capacity is 32 GB.
<b>M-code</b>		M00~M01, M03~M101, and M103~M65535: The execution of a program pauses. (WAIT) You can use them freely.
<b>G-code</b>		G0 (rapid positioning), G1 (linear interpolation), G2 (circular interpolation, clockwise), G3 (circular interpolation, counterclockwise), G4 (dwell), G17 (XY plane selection), G18 (ZX plane selection), G19 (YZ plane selection), G90 (absolute programming), and G91 (incremental programming)
<b>Number of counters</b>		6
<b>Number of high-speed capture/comparison</b>		6
<b>Number of interrupt devices</b>		216

---

# Chapter 2 Hardware Setup

## Table of Contents

- 2.1 Installation.....2-2**
  - 2.1.1 CPU Rack Installation in a Control Panel .....2-2
  - 2.1.2 Mounting a Backplane .....2-2
  - 2.1.3 Installing a CPU Module .....2-4
  
- 2.2 Wiring .....2-6**
  - 2.2.1 Basic System Configurations.....2-6
  - 2.2.2 Wiring Power Supply Modules .....2-6
  - 2.2.3 Wiring AH Motion Controller CPU Modules..... 2-12

## 2.1 Installation

This section introduces the installation of the basic configuration with backplanes and CPU/modules. For detailed installation information including other components, please refer to *AH Motion Controller – Hardware Manual*.

### 2.1.1 CPU Rack Installation in a Control Panel

The essential steps of installing an AH Motion Controller system begin with mounting a motion backplane.

The motion controller has to be installed in a closed control box. In order to ensure that the PLC dissipates heat properly, the space between the motion controller and the control box has to be larger than 50 millimeters.

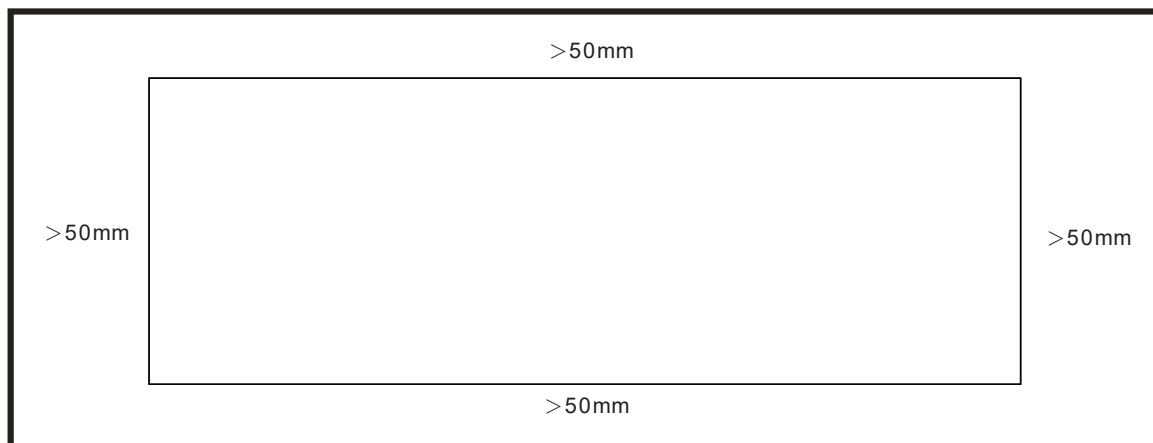

- Keep the motion controller away from high-voltage equipment, high-voltage wires, and high-voltage motors.
- In order to prevent the temperature of a motion controller from rising, do not install the motion controller vertically on the bottom/top in the control box.
- Install a motion controller horizontally in the control box, as shown above.
- If you intend to increase the number of modules, you have to leave some space for installing the modules in the control box.

### 2.1.2 Mounting a Backplane

#### ■ Fixing a backplane by screws

Mount the backplane on a plane by means of M5 screws, as illustrated below. To fix the backplane, you need to evaluate the length of a screw, the size of a thread, and whether to use a nut according to the actual condition of the plane unless there are specific specifications for a screw which are indicated in the pictures below.

1. Tighten the M5 screws in the holes indicated by **a**.

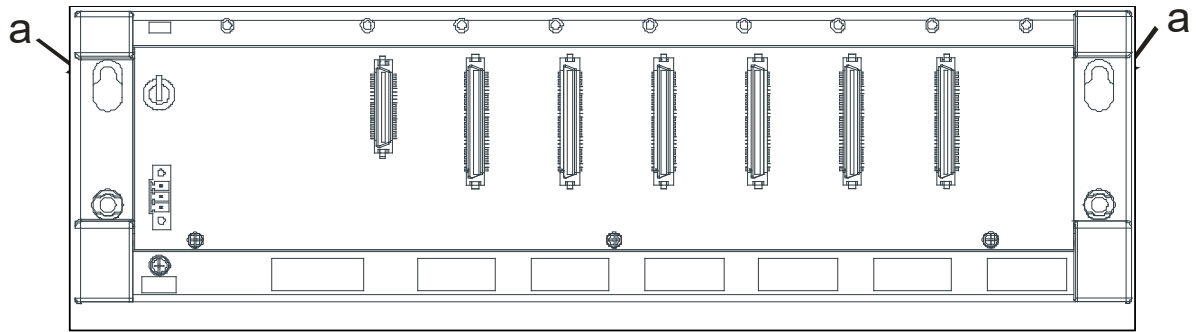

2. Tighten the two screws in the holes indicated by **b**.

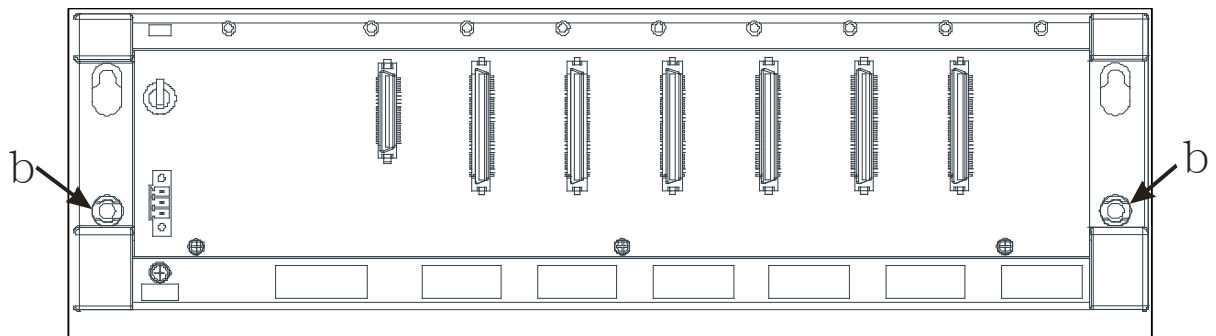

2

### ■ Installing a DIN rail

1. The installation is applicable to a 35 millimeter DIN rail.
2. Install the mounting clips on a backplane.

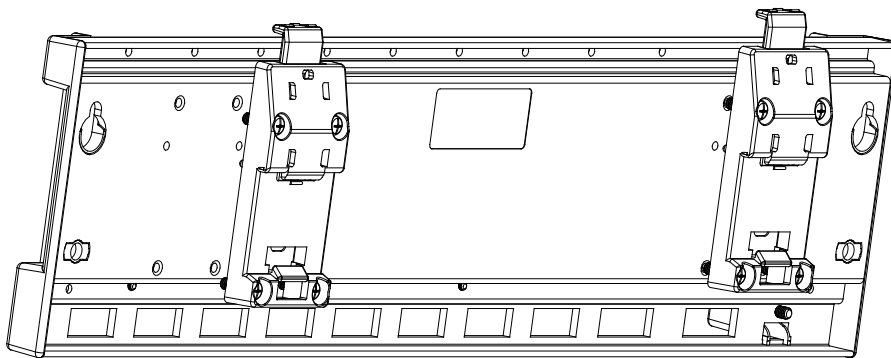

3. Install the backplane on a DIN rail.

Step 1: Press the hook in the direction indicated by the arrow.

Step 2: Mount the DIN rail clips onto a DIN rail.

Step 3: Pull the hook to fix the clips and the DIN rail.



2

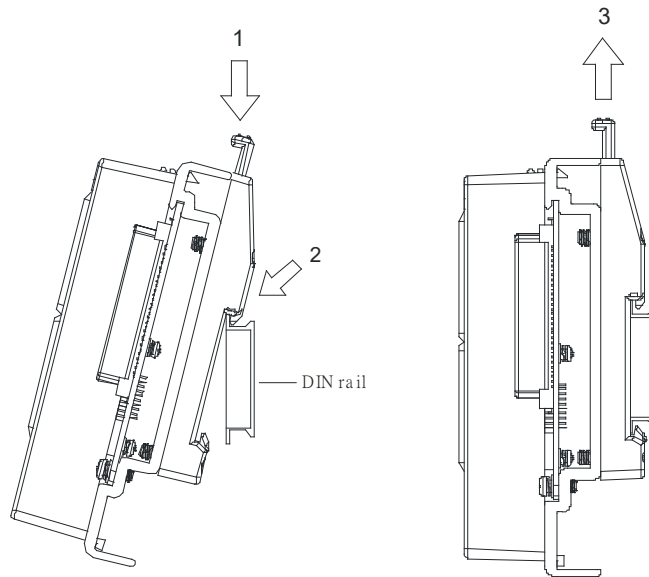

### ■ Removing a DIN rail

Step 1: Press the hook in the direction indicated by the arrow.

Step 2: Remove the backplane.

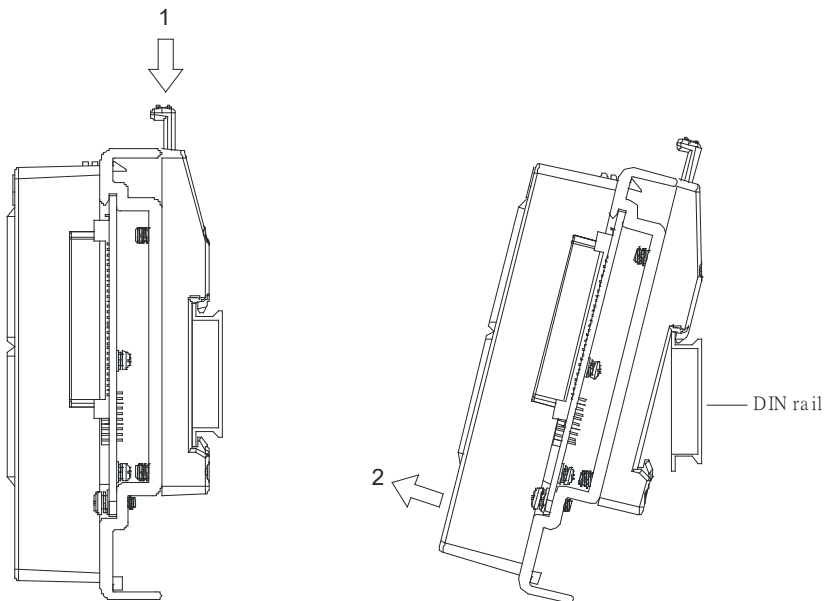

### 2.1.3 Installing a CPU Module

Insert a module into a slot, make sure that the module is installed on the backplane properly, and tighten the the screw, as illustrated below.

1. Insert the hook under the module into the hole in the backplane.

2. Push the module in the direction indicated by the arrow until it clicks.

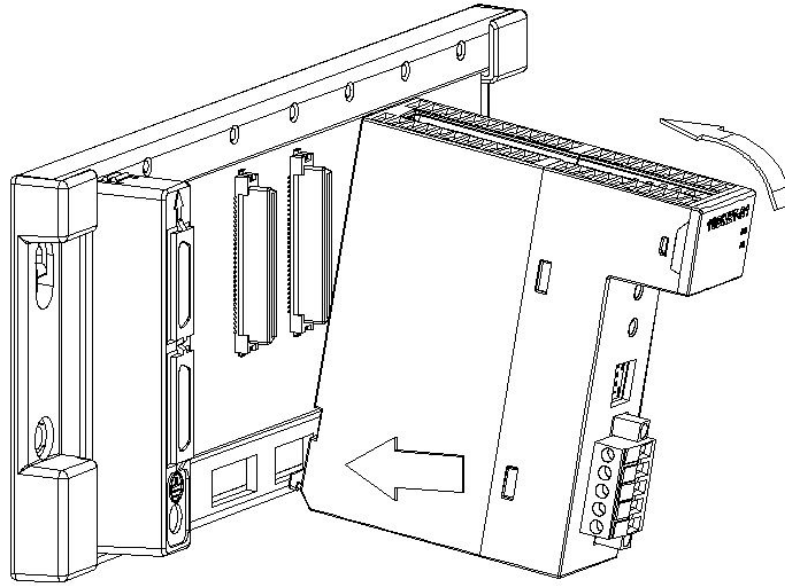

2

3. Tighten the screw on the module.

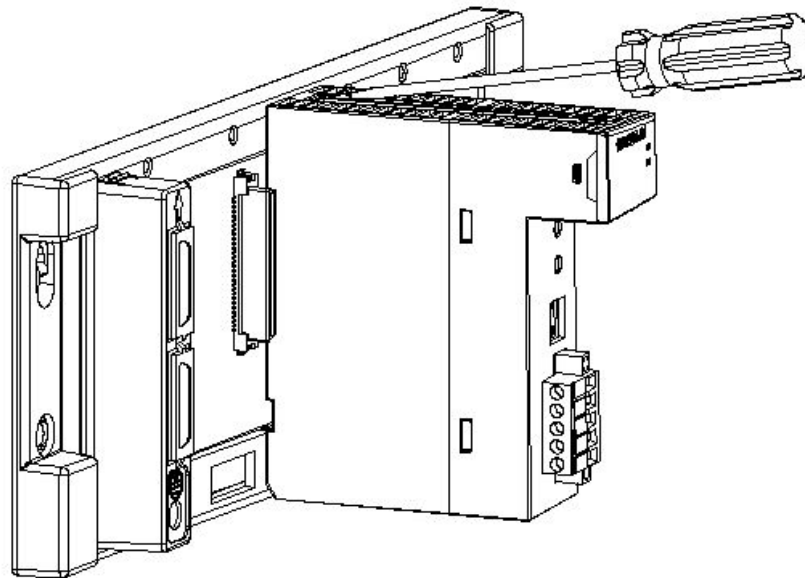

## 2.2 Wiring

This section introduces the connection structure and the wiring of the basic configuration with power supplies and CPUs. For detailed wiring information including other components, please refer to *AH Motion Controller– Hardware Manual*.

### 2.2.1 Basic System Configurations

The AH Motion Controller series CPU basic configurations include the **AH Motion Controller CPU Network Configuration**, **AH500 Series Module Configuration**, and **Supported Software**. Refer to the below diagram for the overview of the system connection structure.

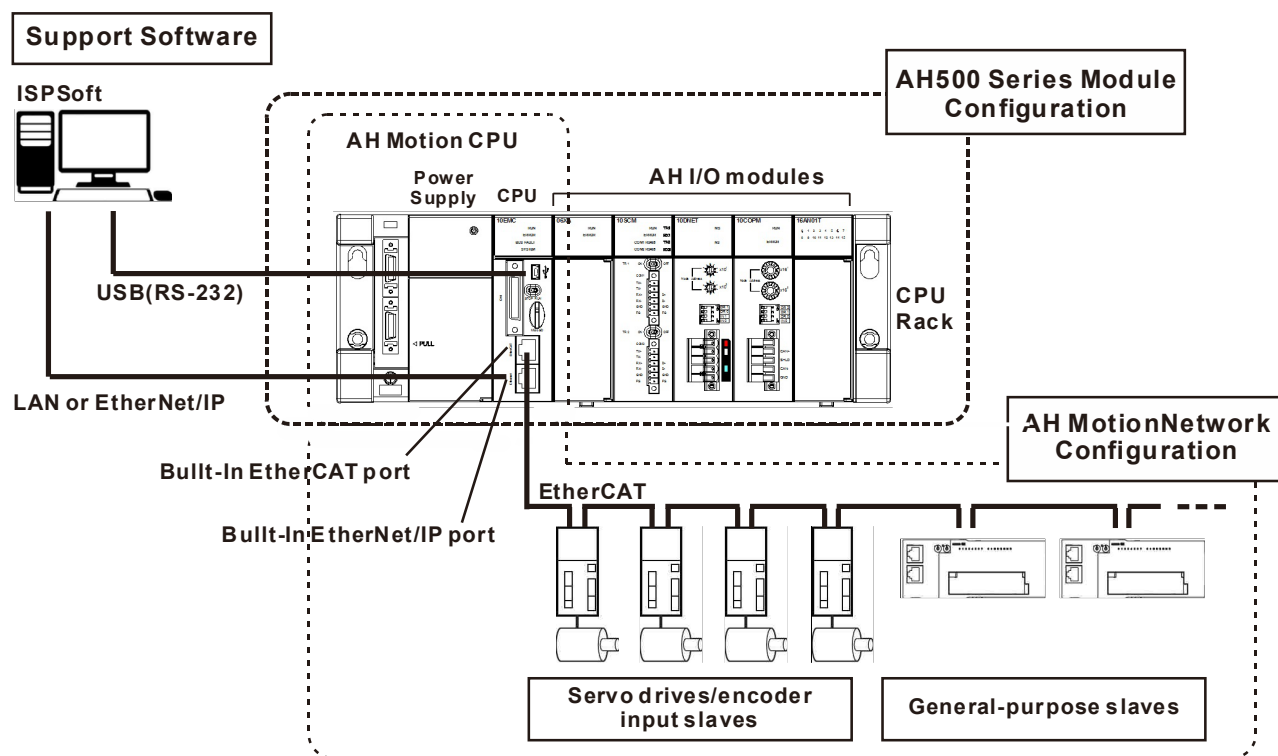

### 2.2.2 Wiring Power Supply Modules

#### ● Precautions

##### ■ Connecting AC power cables

1. Please separate the power cable of AHPS05-5A from the power cables for I/O devices and other devices. If there is much noise, connect an isolating transformer.

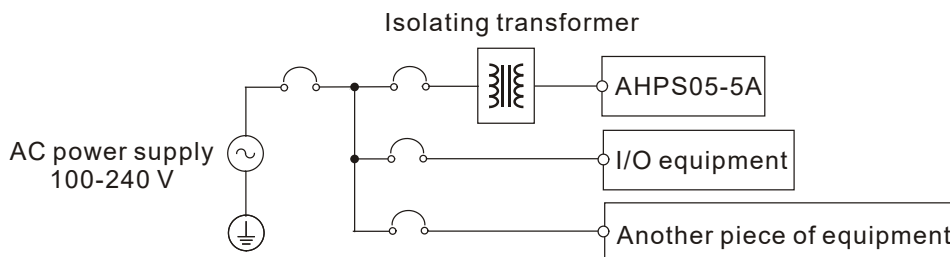

2. The 110 VAC cable, the 220 VAC cable, and the 24 VDC cable should be twisted, and connected to a module within a short distance.
3. Do not bundle 110 VAC cable, the 220 VAC cable, the 24 VDC cable, the (high-voltage high-current) main circuit, and the I/O signal cable together. Besides, it is recommended that the distance between adjacent cables should be more than 100 millimeters.
4. To prevent the surge resulting from lightning, please install a surge absorber in the way shown below.

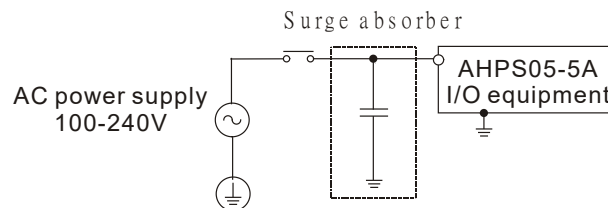

**Points for attention:**

1. The surge absorber and the PLC system should be grounded separately.
2. Please select the surge absorber whose working voltage is not less than the maximum allowable input voltage.

■ **Connecting DC power cables**

1. AHPS15-5A is independently supplied with power by a DC power supply. Please separate the power cable of the DC power supply from the power cables for I/O devices and other devices. If there is much noise, connect an isolating transformer.

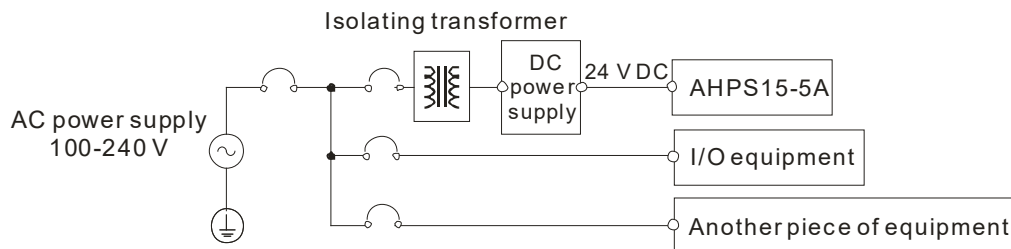

2. The 110 VAC cable, the 220 VAC cable, and the 24 VDC cable should be twisted, and connected to a module within a short distance.
3. Do not bundle 110 VAC cable, the 220 VAC cable, the 24 VDC cable, the (high-voltage high-current) main circuit, and the I/O signal cable together. Besides, it is recommended that the distance between adjacent cables should be more than 100 millimeters.
4. To prevent the surge resulting from lightning, please install a surge absorber in the way shown below.

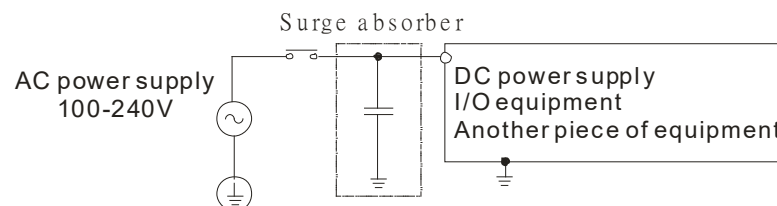

**Points for attention:**

1. The surge absorber and the PLC system should be grounded separately.
2. Please select the surge absorber whose working voltage is not less than the maximum allowable input voltage.

● **Ground**

- The diameter of the ground should not be less than the diameters of the cables connected to the terminals L and N.

- If much equipment is used, please use single-point ground.

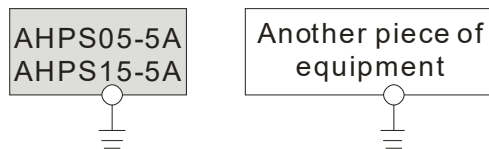

The single-point ground is better.

- If single-point ground cannot be used, please use common-point ground.

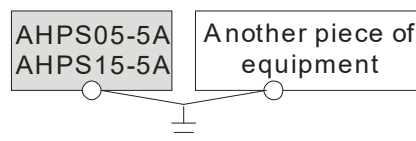

The common-point ground is permitted.

- You cannot ground equipment in the way shown on the right.

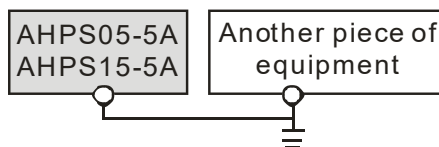

The equipment can not be grounded in this way.

● **Wiring Power Supply Modules**

- Connecting an AC power cable

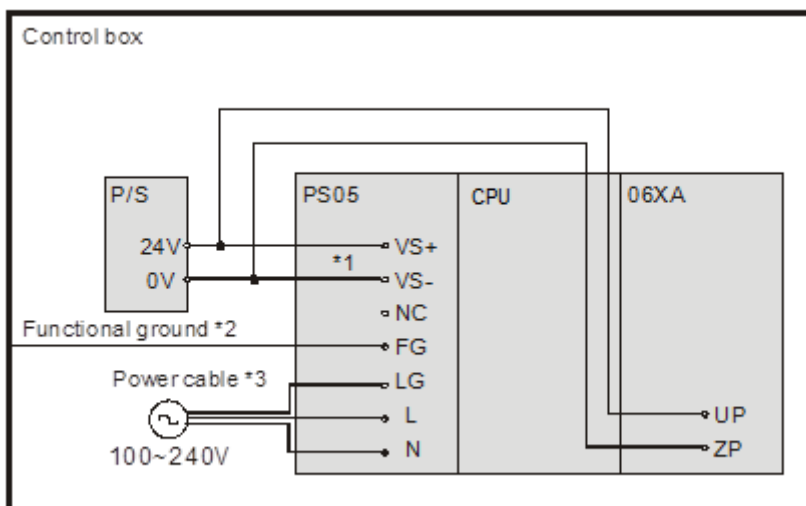

\*1. 24V on the external power supply is connected to VS+ and VS- on the power supply module. VS+ and VS- can be used to detect whether the voltage of the external power supply is stable.

\*2. FG on the power supply module is connected to the control box as the functional ground.

\*3. The live wire and the neutral wire in the AC power cable are connected to L and N on the power supply module

respectively. To prevent the system from becoming abnormal, the ground in the AC power cable has to be connected to LG on the power supply module.

The power input of AHPS05-5A is the AC input. You have to pay attention to the following points when you use AHPS05-5A.

- The alternating-current input voltage is in the range of 100 VAC to 240 VAC. Please connect the power supply to the terminals L and N. If the 110 VAC or the 220 VAC power supply is connected to the input terminals VS+ and VS-, the PLC will be damaged.
- In order to ensure that the external power supply stably provides 24 VDC power, the external power supply can be connected to VS+ and VS-. If the PLC detects that the voltage of the external power supply is lower than the working voltage, you can write a protective program.
- The length of the cable connecting with the ground should be more than 1.6 millimeters.
- If the power cut lasts for less than 10 milliseconds, the PLC keeps running without being affected. If the power cut lasts for long, or if the voltage of the power supply decreases, the PLC stops running, and there is no output. When the power supply returns to normal, the PLC resumes. (You have to notice that there are latched auxiliary relays and registers in the PLC when you write the program.)
- Please use single-core cables or multicore cables. The diameters of the cables used should be in the range of 12 AWG to 22 AWG. The torque applied to the terminal screws should be 9.50 kg-cm (8.25 lb-in). Please use copper conducting wires. The temperature of the copper conductive cables should be 60/75°C.
- Safety wiring: The PLC controls many devices, and the activity of any device affects the activity of other devices. If any device breaks down, the whole automatic control system goes out of control, and the danger occurs. The protection circuit is shown below.

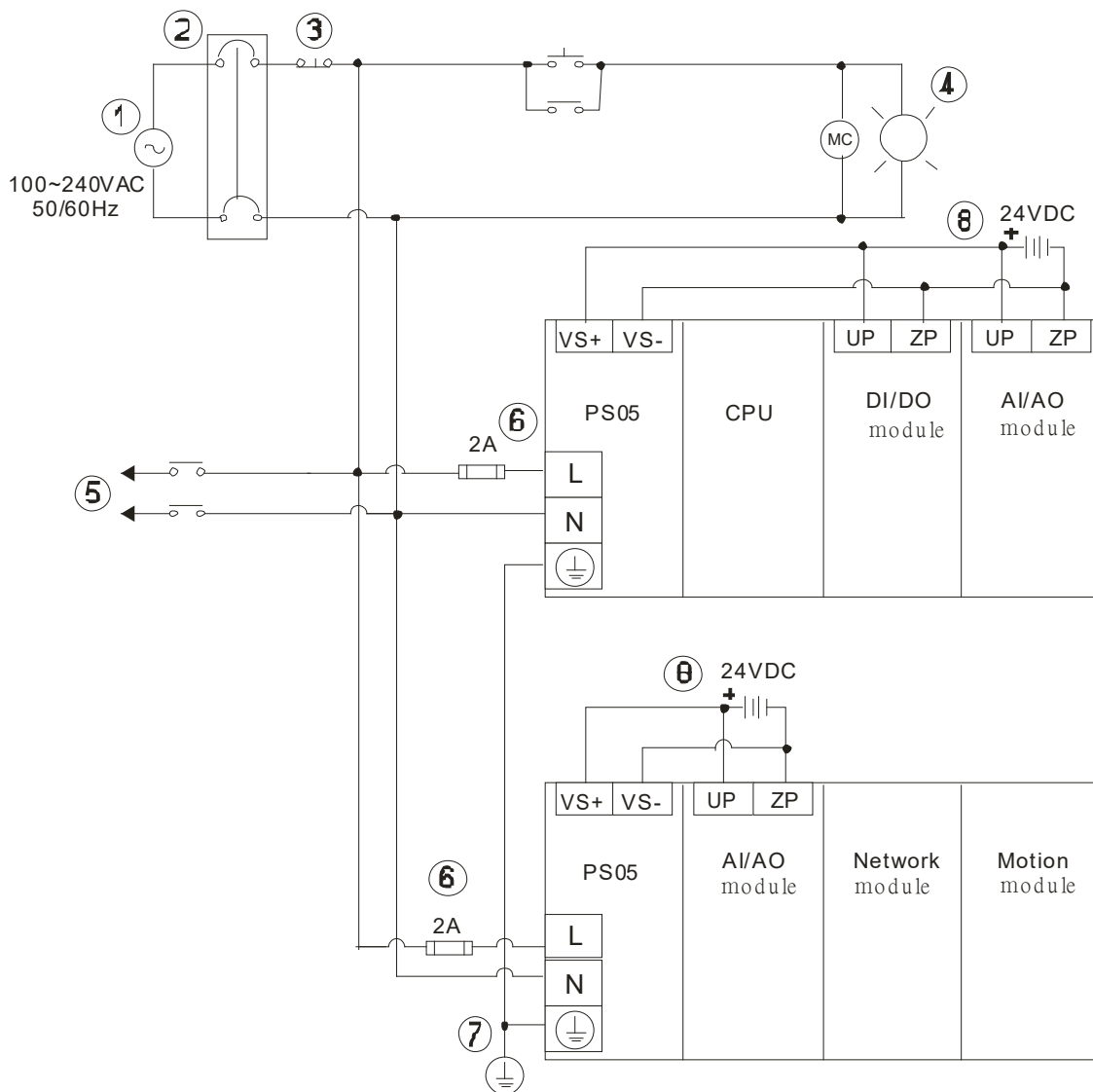

2

	Alternating-current power supply: 100~240 VAC, and 50/60 Hz
	Circuit breaker
	Emergency stop: The emergency stop button can be used to cut off the power when an emergency occurs.
	Power indicator
	Load through which the alternating current passes
	2 A fuse
	The ground impedance is less than 100 Ω.
	Direct-current power supply: 24 VDC

- Connecting a DC power cable

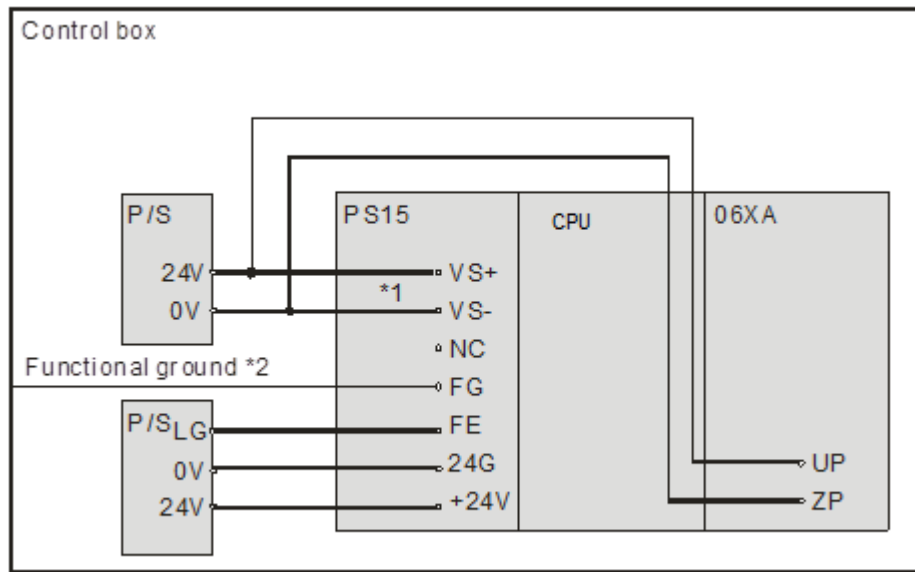

\*1. 24V on the external power supply is connected to VS+ and VS- on the power supply module. VS+ and VS- can be used to detect whether the voltage of the external power supply is stable.

\*2. FG on the power supply module is connected to the control box as the functional ground.

\*3. +24V and 24G on the power supply module are connected to 24V and 0V on the DC power supply. To prevent the system from becoming abnormal, the ground of the DC power supply has to be connected to FE on the power supply module.

The power input of AHPS15-5A is the DC input. You have to pay attention to the following points when you use AHPS15-5A.

- In order to ensure that the external power supply stably provides 24 VDC power, the external power supply can be connected to VS+ and VS-. If the PLC detects that the voltage of the external power supply is lower than the working voltage, you can write a protective program.
- The length of the cable connecting with the ground should be more than 1.6 millimeters.
- If the power cut lasts for less than 10 milliseconds, the PLC keeps running without being affected. If the power cut lasts for long, or if the voltage of the power supply decreases, the PLC stops running, and there is no output. When the power supply returns to normal, the PLC resumes. (You have to notice that there are latched auxiliary relays and registers in the PLC when you write the program.)
- Please use single-core cables or multicore cables. The diameters of the cables used should be in the range of 12 AWG to 22 AWG. The torque applied to the terminal screws should be 9.50 kg-cm (8.25 lb-in). Please use copper conducting wires. The temperature of the copper conductive cables should be 60/75°C.



## 2.2.3 Wiring AH Motion Controller CPU Modules

### 2.2.3.1 Specifications of Inputs and Outputs for Wiring

#### ■ AHxxEMC-5A

##### Description of the terminals

Terminal	Description	Response characteristic	Rated input	
			Current	Voltage
<b>X0.0+, X0.0-, X0.1+, X0.1-</b>	1. Differential input terminals. 2. The functions of the terminals: <ul style="list-style-type: none"> <li>● High-speed count:                             <ul style="list-style-type: none"> <li>◆ The terminals are the RESET input terminals for counter 0~counter 1.</li> <li>◆ X0.0+ and X0.0- are for counter 0.</li> <li>◆ X0.1+ and X0.1- are for counter 1.</li> <li>◆ High-speed capture: The terminals can function as trigger signals for high-speed captures.</li> </ul> </li> </ul>	1MHz	+/-5mA	+/-5V
<b>X0.2, X0.3, X1.4, X1.5</b>	1. Common input terminals. 2. The functions of the terminals: <ul style="list-style-type: none"> <li>● High-speed count:                             <ul style="list-style-type: none"> <li>◆ The terminals are the RESET input terminals for counter 2~counter 5.</li> <li>◆ X0.2 is for counter 2.</li> <li>◆ X0.3 is for counter 3.</li> <li>◆ X1.4 is for counter 4</li> <li>◆ X1.5 is for counter 5</li> </ul> </li> <li>● High-speed capture: The terminals can function as trigger signals for high-speed captures.</li> </ul>	100kHz(*1)	5mA	24V
<b>X0.8+, X0.8-, X0.9+, X0.9-</b>	1. Differential input terminals. 2. The functions of the terminals: <ul style="list-style-type: none"> <li>● Motion control: The terminals are for a manual pulse generator.</li> <li>● High-speed count:                             <ul style="list-style-type: none"> <li>◆ The terminals are for counter 0.</li> <li>◆ X0.8+ and X0.8- are the A-phase inputs for counter 0. X0.9+ and X0.9- are the B-phase inputs for counter 0.</li> </ul> </li> <li>● High-speed capture: The terminals can function as trigger signals for high-speed captures.</li> <li>● Interrupt inputs</li> </ul>	1MHz	+/-5mA	+/-5V
<b>X0.10+, X0.10-, X0.11+, X0.11-</b>	1. Differential input terminals. 2. The functions of the terminals: <ul style="list-style-type: none"> <li>● High-speed count:                             <ul style="list-style-type: none"> <li>◆ The terminals are for counter 1.</li> <li>◆ X0.10+ and X0.10- are the A-phase inputs for counter 1. X0.11+ and X0.11- are the B-phase inputs for counter 1.</li> </ul> </li> <li>● High-speed capture: The terminals can function as trigger signals for high-speed captures.</li> <li>● Interrupt inputs</li> </ul>	1MHz	+/-5mA	+/-5V

Terminal	Description	Response characteristic	Rated input	
			Current	Voltage
X0.12, X0.13, X0.14, X0.15, X1.0, X1.1, X1.2, X1.3	1. Common input terminals. 2. The functions of the terminals: <ul style="list-style-type: none"> <li>● High-speed count:                             <ul style="list-style-type: none"> <li>◆ The terminals are for counter 2~counter 5.</li> <li>◆ X0.12 and X0.13 are for counter 2.</li> <li>   X0.14 and X0.15 are for counter 3.</li> <li>   X1.0 and X1.1 are for counter 4.</li> <li>   X1.2 and X1.3 are for counter 5.</li> </ul> </li> <li>● High-speed capture: The terminals can function as trigger signals for high-speed captures.</li> <li>● Interrupt inputs: X0.12, X0.13, X0.14 and X0.15 can function as interrupt inputs.</li> </ul>	100kHz(*1)	5mA	24 V
Y0.8, Y0.9, Y0.10, Y0.11	1. Pulse output terminals (open collector). 2. The function of the terminals: <ul style="list-style-type: none"> <li>● High-speed comparison: The terminals can function as high-speed comparison outputs.</li> </ul>	200 kHz	15 mA	24 V

\*1. If the frequency of input signals received by an input terminal must be 200 kHz, the input terminal must be connected to a 1 kΩ (2 W) resistor in parallel.

### 2.2.3.2 Wiring AHxxEMC-5A

■ External devices for AHxxEMC-5A

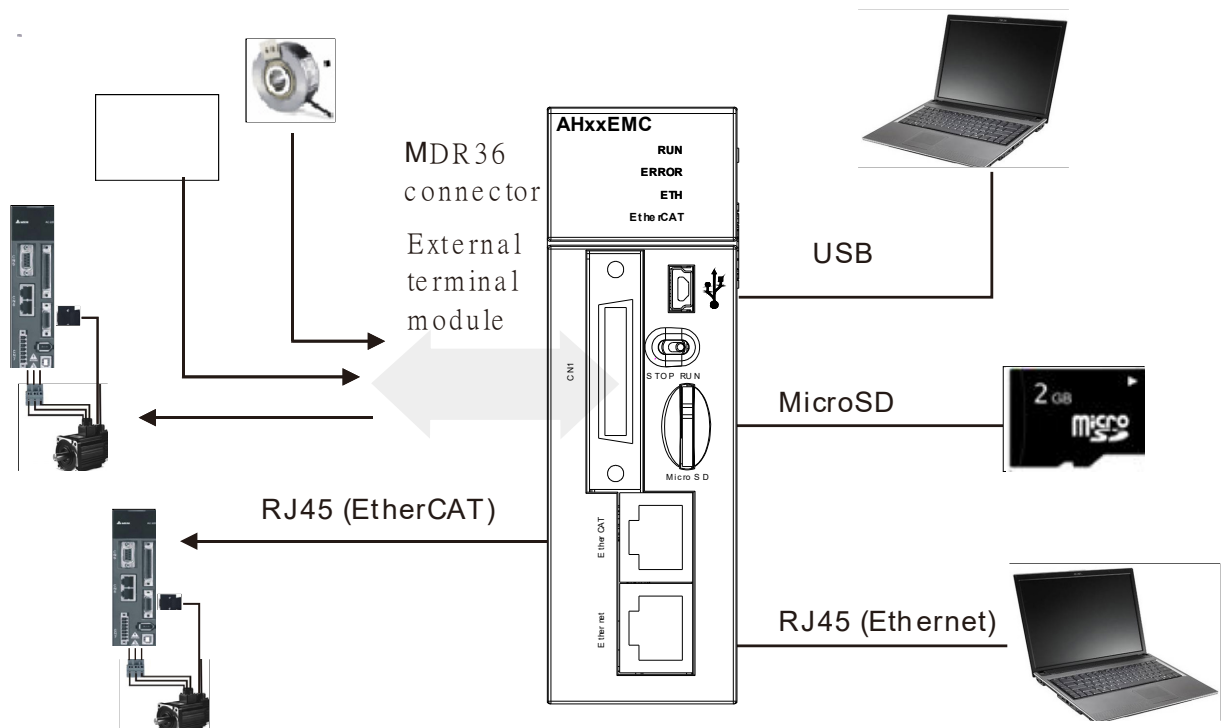

■ MDR36 connector

Pin	Function	Pin	Function
1	COM	19	Y0.11
2	COM	20	Y0.10
3	COM	21	Y0.9
4	COM	22	Y0.8
5	S/S	23	X1.3
6	X1.5	24	X1.2
7	S/S	25	X1.1
8	X1.4	26	X1.0
9	S/S	27	X0.15
10	X0.3	28	X0.14
11	S/S	29	X0.13
12	X0.2	30	X0.12
13	X0.1-	31	X0.1+
14	X0.11-	32	X0.11+
15	X0.10-	33	X0.10+
16	X0.0-	34	X0.0+
17	X0.9-	35	X0.9+
18	X0.8-	36	X0.8+

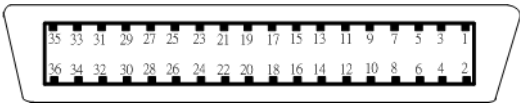

■ USB port

Pin	Function
1	VBUS (4.4–5.25 V)
2	D-
3	D+
4	Ground
5	Ground



■ EtherNet/IP port

Pin	Signal	Description
1	TX+	Transmitting data (positive pole)
2	TX-	Transmitting data (negative pole)
3	RX+	Receiving data (positive pole)

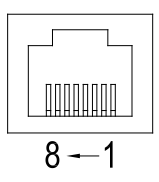

4	--	N/C
5	--	N/C
6	RX-	Receiving data (negative pole)
7	--	N/C
8	--	N/C

■ EtherCAT port

Pin	Signal	Description
1	TX+	Transmitting data (positive pole)
2	TX-	Transmitting data (negative pole)
3	RX+	Receiving data (positive pole)
4	--	N/C
5	--	N/C
6	RX-	Receiving data (negative pole)
7	--	N/C
8	--	N/C

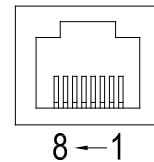

2

■ Wiring the Differential Input Terminals

The direct-current signals in voltage 5 V can pass through the high-speed input terminals X0.0+~X0.1+, X0.0~X0.1-, X0.8+~X0.11+, and X0.8~X0.11- on AHxxEMC-5A. The frequency of input signals can be up to 1 MHz. These high-speed input terminals are connected to a differential (two-wire) line driver.

- Wiring differential input terminals (The wiring below is used for high speed and high noise.)

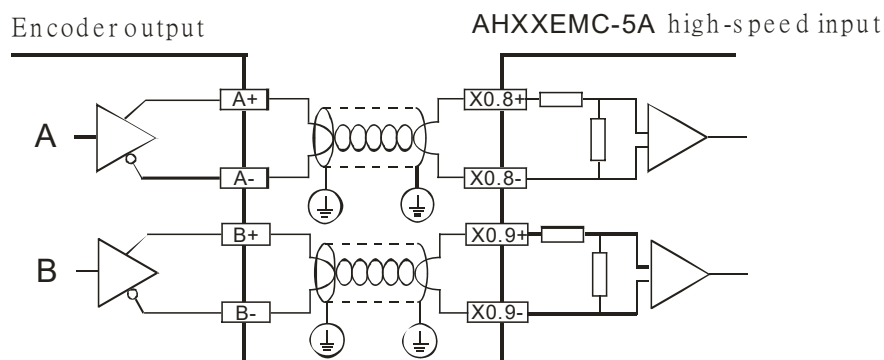

■ Transistor Output Circuit

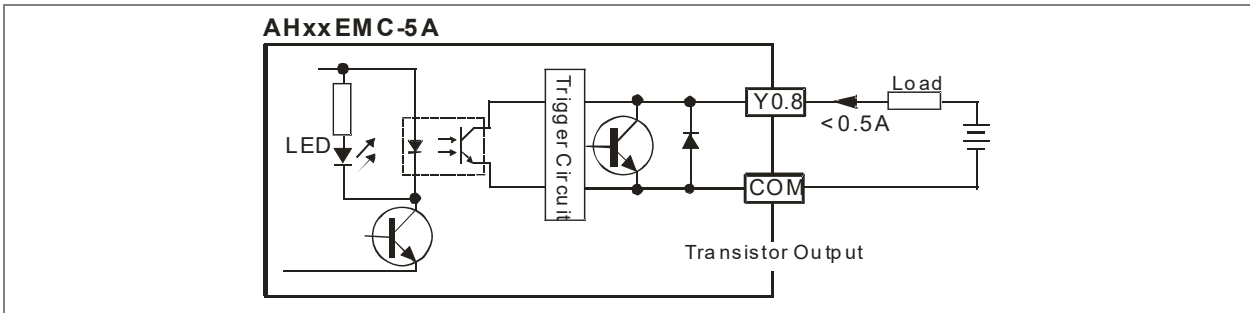

2

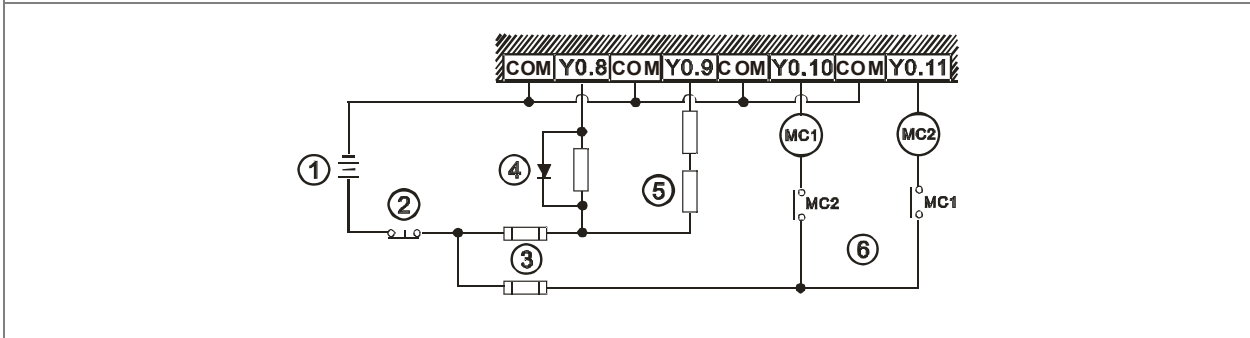

①	Direct-current power supply	②	Emergency stop	③	Fuse
---	-----------------------------	---	----------------	---	------

④ The output terminals of a transistor module are open-collector output terminals. If Y0.8 is a pulse train output terminal of a transistor module, the output current passing through its output pull-up resistor must be greater than 0.1 A to ensure that the transistor module operates normally.

A relay or a solenoid valve is used as a DC load. A diode is connected in parallel to absorb the surge voltage which occurs when the load is OFF.

D: 1N4001 diode

<p>⑤</p>	<p>A bulb (incandescent lamp) is used as a DC load. A thermistor is connected in series to absorb the surge current which occurs when the load is ON.</p> <p><b>AHxxEMC-5A</b></p> <p>NTC: 10Ω</p> <p>Y0.9 can not be connected to a power supply directly. It must be connected to a load.</p> <p><b>AHxxEMC-5A</b></p>
<p>⑥</p>	<p>Mutually exclusive output: For example, Y0.10 controls the clockwise rotation of the motor, and Y0.11 controls the counterclockwise rotation of the motor. The interlock circuit which is formed, and the program in the PLC ensure that there are protective measures if an abnormal condition occurs.</p>

**MEMO**

---

## Chapter 3 Software Setup

### Table of Contents

<b>3.1</b>	<b>Installing and Uninstalling ISPSOft.....</b>	<b>3-2</b>
3.1.1	Installing ISPSOft .....	3-3
3.1.2	Uninstalling ISPSOft .....	3-6
<b>3.2</b>	<b>Installing and Uninstalling COMMGR .....</b>	<b>3-8</b>
3.2.1	Installing COMMGR .....	3-8
3.2.2	Uninstalling COMMGR .....	3-10
<b>3.3</b>	<b>Connecting ISPSOft with AH Motion CPU .....</b>	<b>3-12</b>
3.3.1	Direct connection via USB .....	3-12
3.3.2	Direct connection via Ethernet .....	3-12



Before developing an AH Motion system, you need to install ISPSOFT and COMMGR, which are basic software. ISPSOFT is a platform for integrating the program development of a whole system, hardware configuration, and network configuration. COMMGR functions as middleware between a computer and devices. For example, it functions as a communication management interface between ISPSOFT and AH Motion system hardware.

### 3.1 Installing and Uninstalling ISPSOFT

- System Requirements

Item	System requirements	
Operating system	Windows 2000/NT/Me/XP/Vista/7/8/10	
CPU	Pentium 1.5 G or above	
Memory	256 MB or above (A memory having a capacity of 512 MB or above is recommended.)	
Hard disk drive	Capacity : 500 MB or above	
CD-ROM drive	For installing ISPSOFT It is optionally required.	
Monitor	Resolution: 800×600 or above (Setting which is suggested: 1024x768/96 dpi)	
Keyboard/Mouse	A general keyboard/mouse, or devices compatible with Windows	
Printer	A printer with a driver for Windows (It is used to print a project, and is optionally required.)	
RS-232 port	For connecting to a PLC	One of them is used, but a PLC which is connected must have a corresponding port. (*1)
USB port	For connecting to a PLC	
Ethernet port	For connecting to a PLC	
Communication software	COMMGR, a communication manager, must be installed on a computer. (*2)	
Models which are supported	AH500 series PLCs (including AH Motion CPUs)/DVP series PLCs (exclusive of DVP-PM series PLCs)/VFD-C2000 series AC motor drives/VFD-C200 series AC motor drives/VFD-CP2000 AC motor drives /VFD-E AC motor drives (*3)	

**\*Note:**

- ISPSOFT supports several ways in which a computer is connected to a PLC. You have to make sure of the port and the mode supported by a PLC before a computer is connected to the PLC.
- Please refer to section 3.2 for more information about COMMGR.
- In addition to ISPSOFT, you must use PMSOFT version 2.05 or above to develop AH10PM-5A and AH20MC-5A.
- The functions and specifications mentioned above are only applicable to ISPSOFT version 2.00 or above. The older versions are not equipped with the complete functions.

### 3.1.1 Installing ISPSOft

If an older version of ISPSOft has been installed on a computer, you have to uninstall it before install ISPSOft. Please refer to section 3.1.2 for more information about uninstalling ISPSOft. The following are the steps of installing ISPSOft.

- (1) Start the Windows 2000/NT/Me/XP/Vista/7/8/10 operating system.
- (2) Download the installation program from <http://www.deltaww.com/default.aspx?hl=en-US>. (Before the installation program downloaded from the website is installed, it has to be decompressed.)
- (3) Double-click the **setup** icon to execute the installation program.

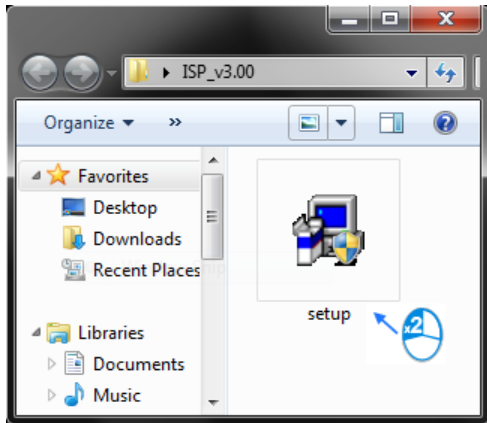

After the **ISPSOft x.xx – InstallShield Wizard** window appears, click **Next**.

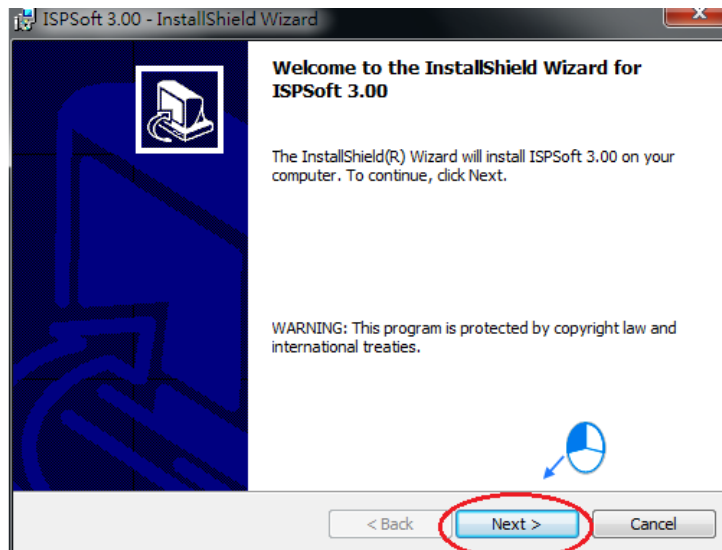

- (4) Type related information in the **User Name** box and **Organization** box, and then click **Next**.

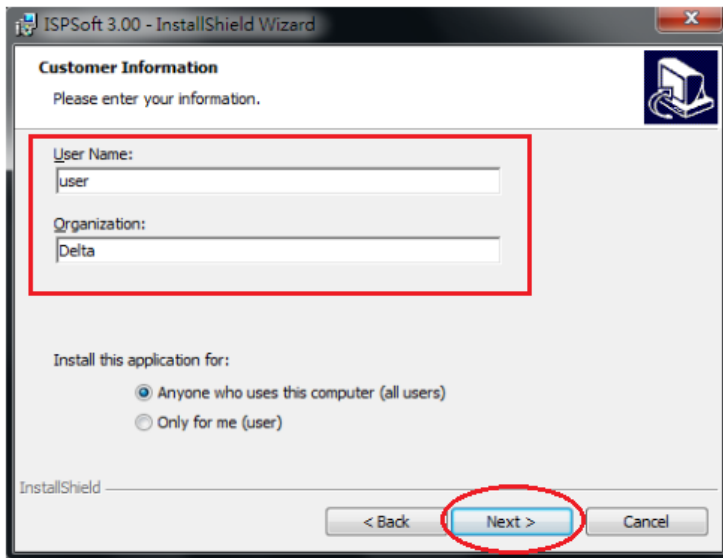

- (5) Leave the default path unchanged, or click **Change...** to change the path. Click **Next** to proceed to the next step.

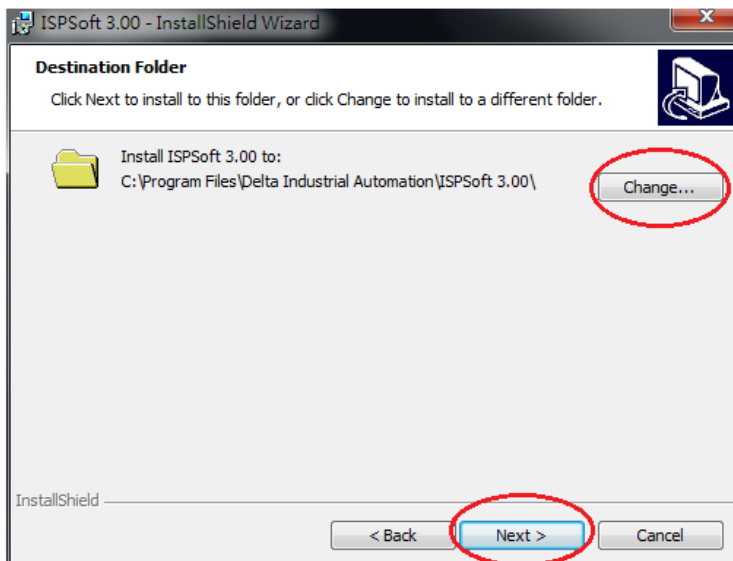

- (6) Check the installation information, and then click **Install**.

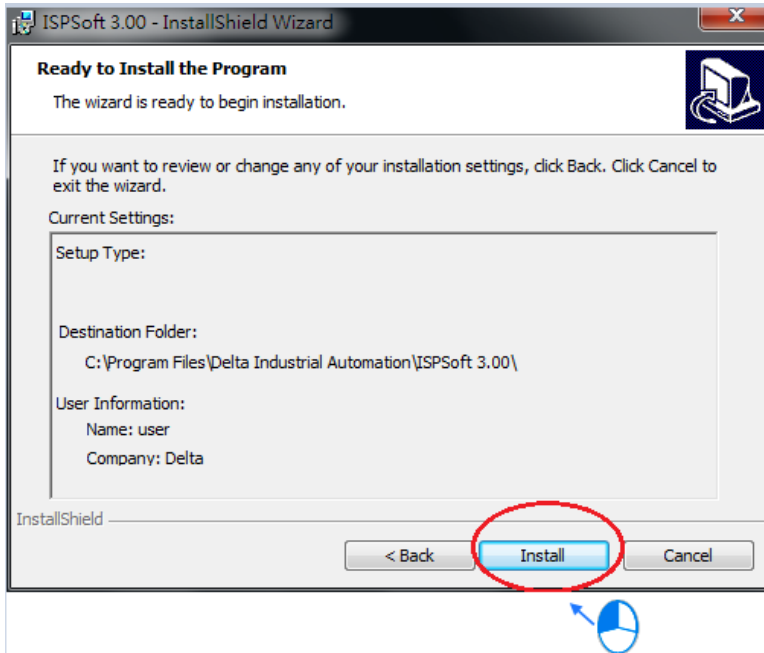

- (7) After ISPSOft is installed, shortcuts to the program are created on the desktop and the **Start** menu. Click **Finish** to complete the installation.

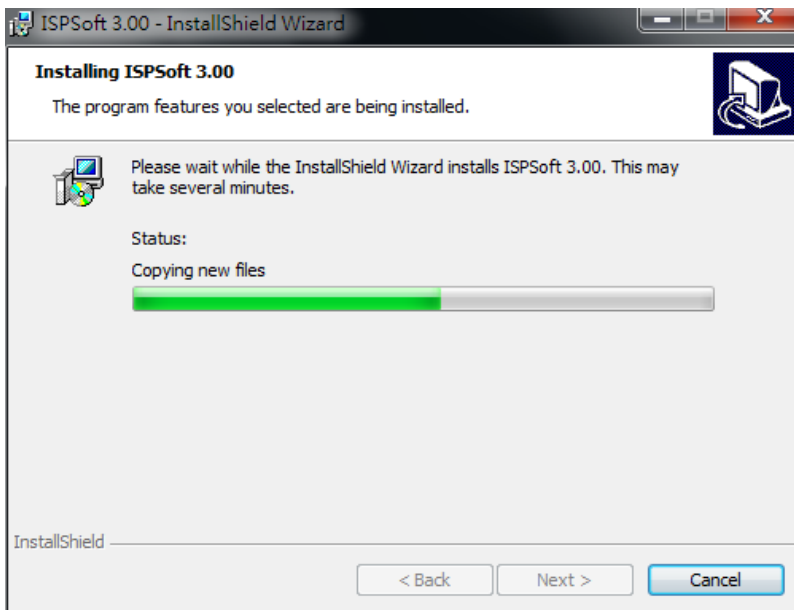

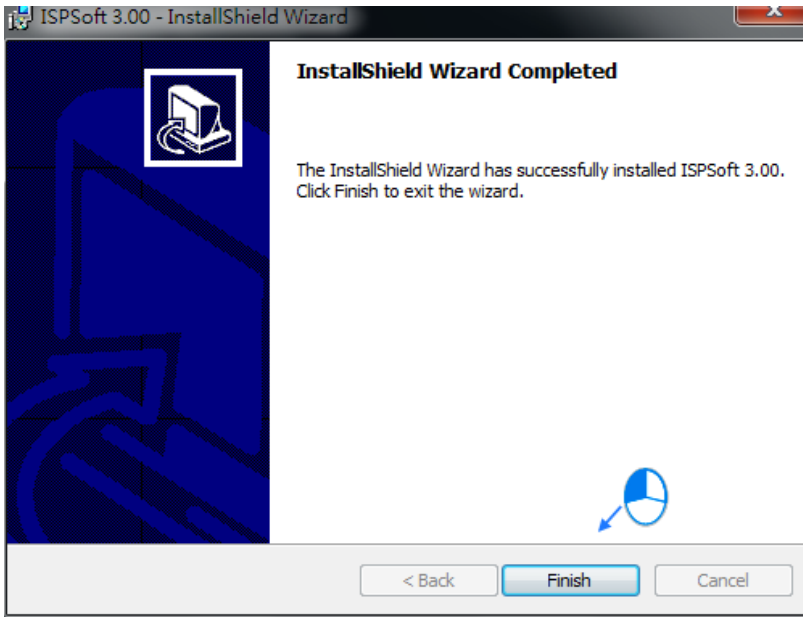

3

### 3.1.2 Uninstalling ISPSOft

(1) There are two methods of uninstalling ISPSOft.

- Method 1: Open the **Control Panel** window, and click **Uninstall or change a program** In the **Currently installed programs** box, click **ISPSOft x.xx**, and then click **Uninstall**

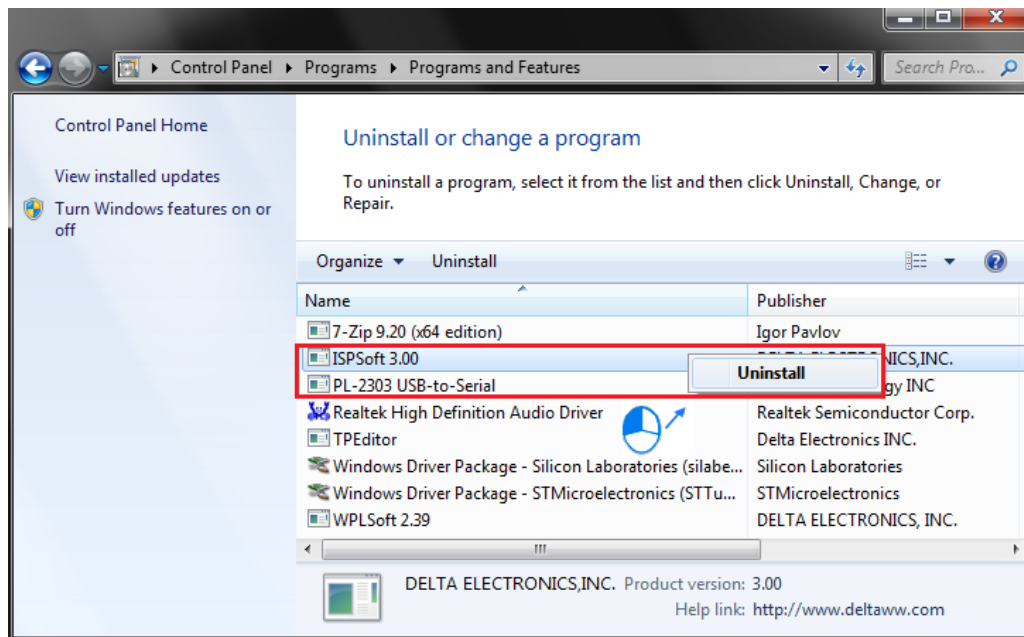

- Method 2: **Start>Programs>Delta Industrial Automation>PLC>ISPSOft x.xx>Uninstall**

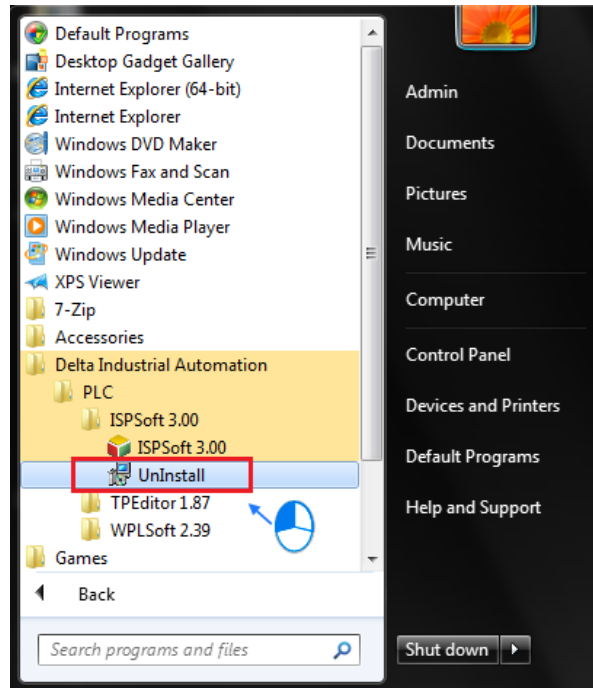

- (2) After you click **Yes**, ISPSOft will be removed.

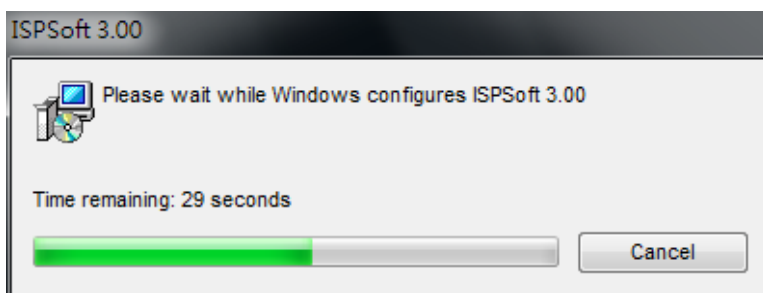
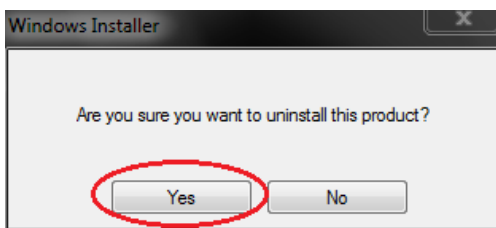

## 3.2 Installing and Uninstalling COMMGR

### 3.2.1 Installing COMMGR

If an older version of COMMGR has been installed on a computer, you have to uninstall it before install COMMGR. Please refer to section 3.2.2 for more information about uninstalling COMMGR. The following are the steps of installing COMMGR.

- (1) Start the Windows 2000/NT/Me/XP/Vista/7/8/10 operating system.
- (2) Download the installation program from <http://www.deltaww.com/default.aspx?hl=en-US>. (Before the installation program downloaded from the website is installed, it has to be decompressed.)
- (3) Double-click the **setup** icon to execute the installation program.

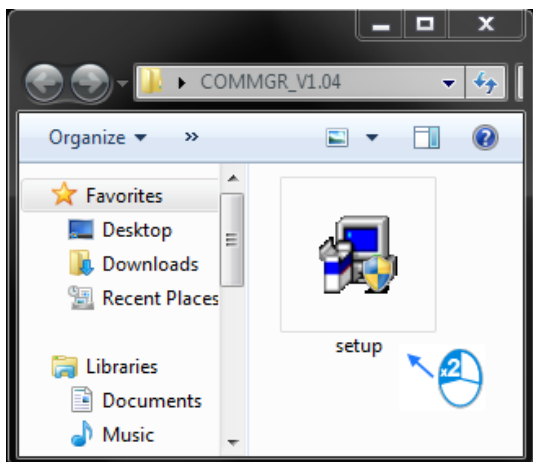

- (4) After the COMMGR x.xx – InstallShield Wizard window appears, click **Next**.

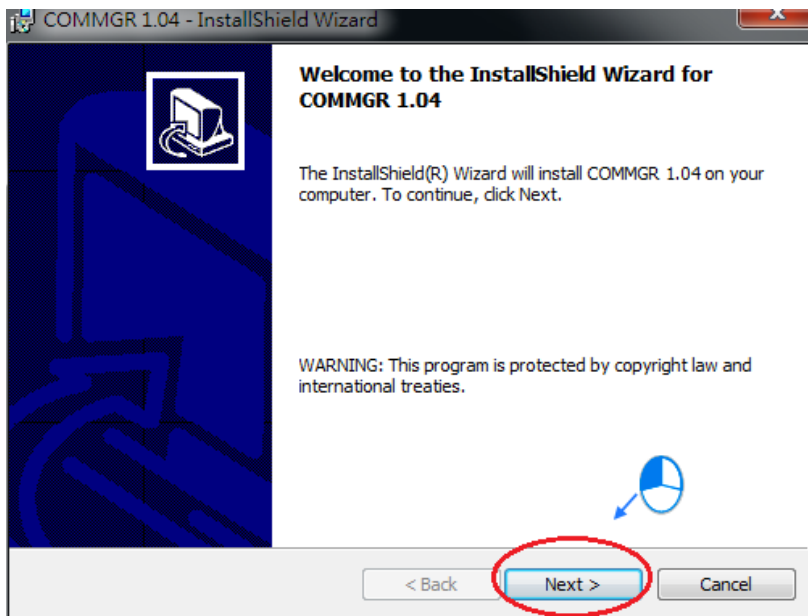

- (5) Type information in the User Name box and the Organization box, and then click Next.

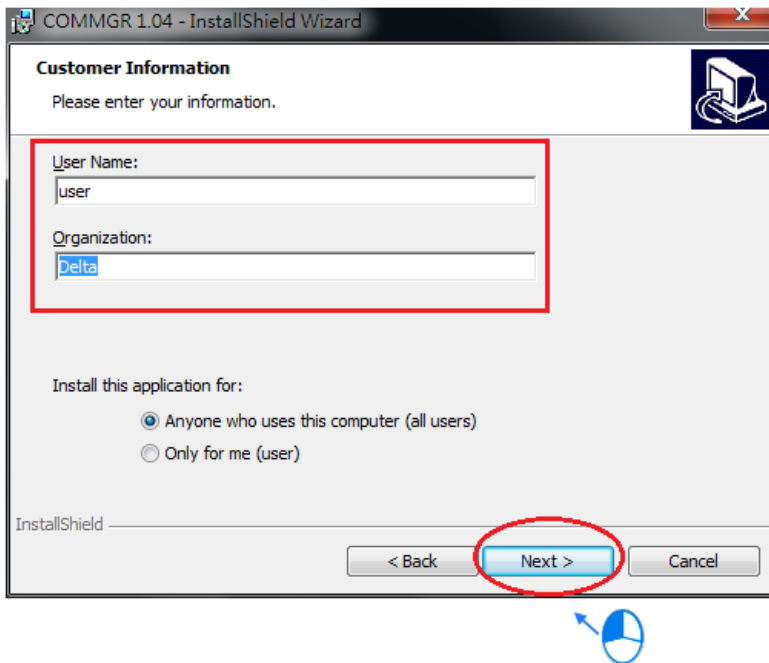

- (6) Check the installation information, and then click **Install**.

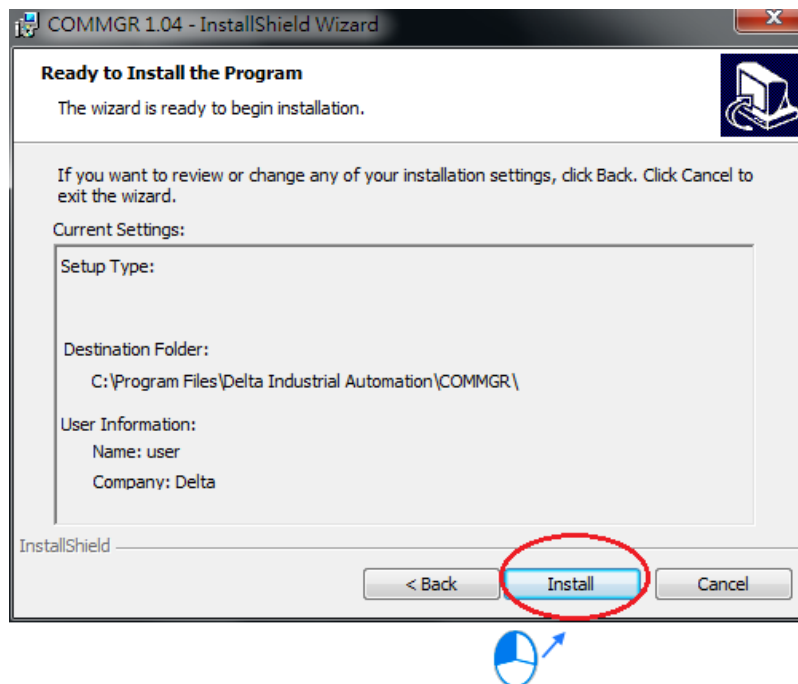



- (7) After COMMGR is installed, a shortcut to the program is created on the **Start** menu. Click **Finish** to complete the installation.

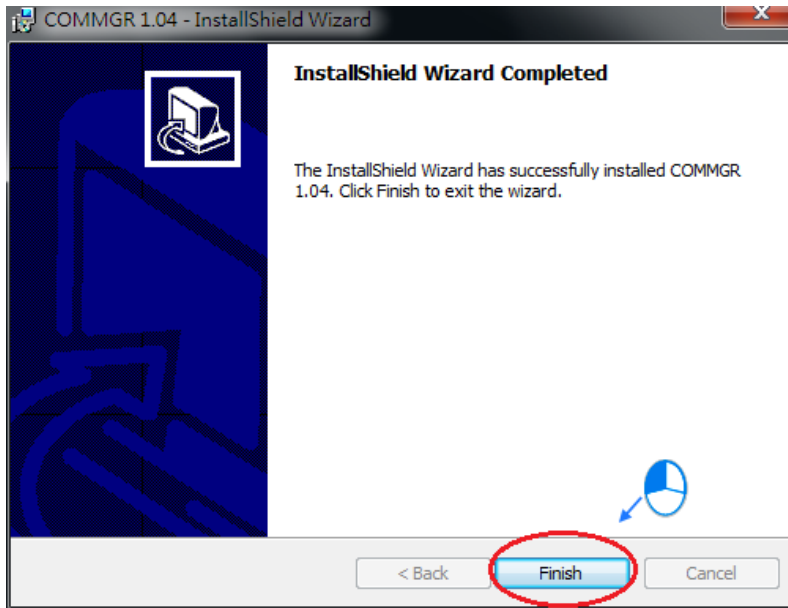

### 3.2.2 Uninstalling COMMGR

- (1) There are two methods of uninstalling COMMGR.

- Method 1: Open the **Control Panel** window, and click **Uninstall or change a program**. In the **Currently installed programs** box, click **COMMGR x.xx**, and then click **Uninstall**.

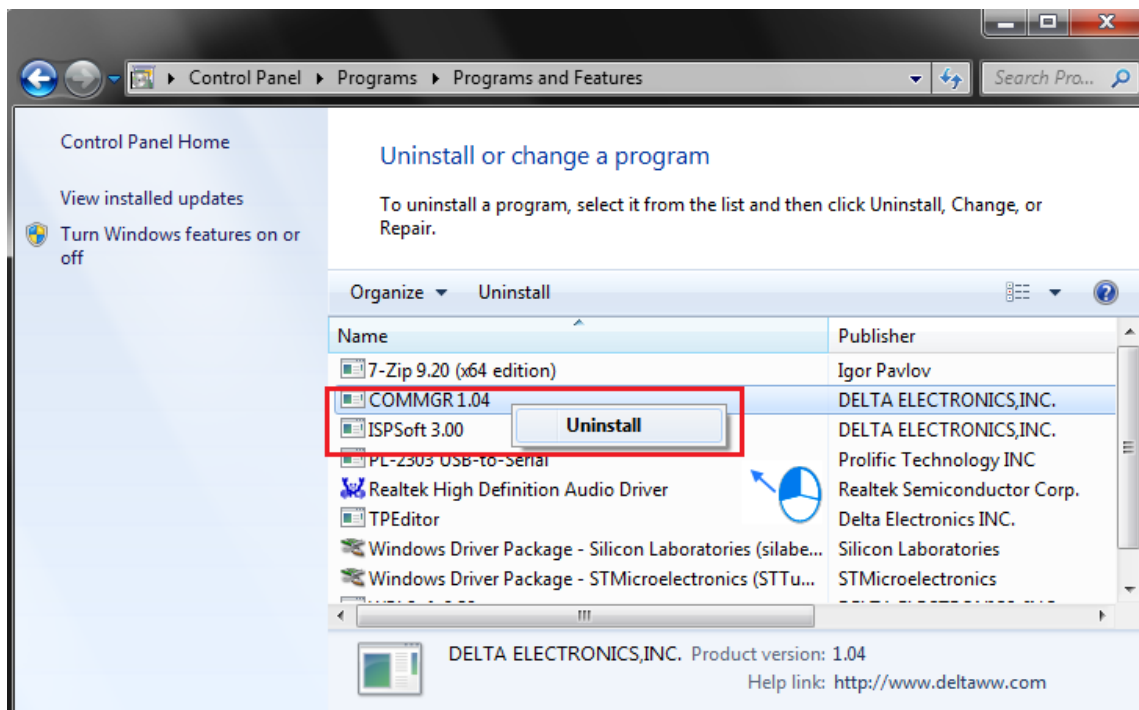

- Method 2: **Start>Programs>Delta Industrial Automation>Communication>COMMGR>Uninstall**

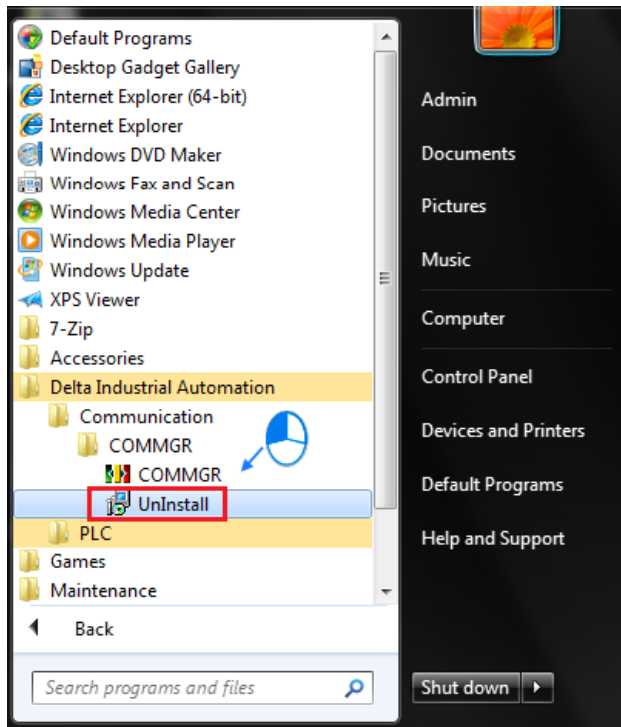

- (2) After you click **Yes**, COMMGR will be removed.

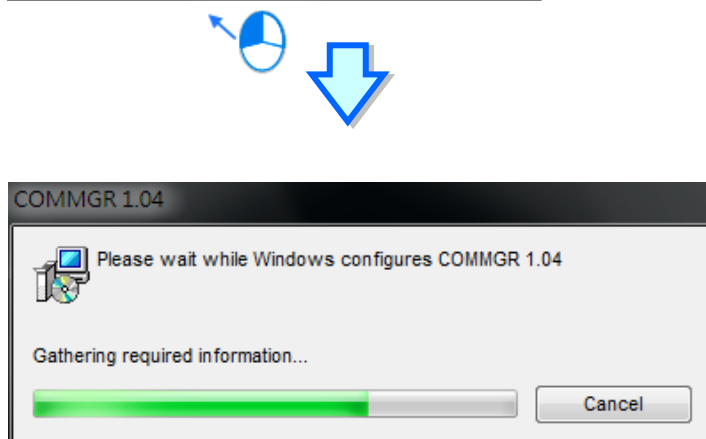
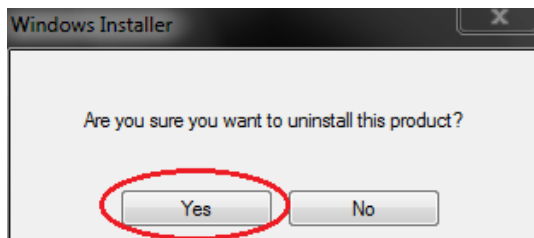

### 3.3 Connecting ISPSOft with AH Motion CPU

There are two types of hardware connections that can be used to go online with a Controller.

#### 3.3.1 Direct connection via USB

The USB port on the computer is connected directly to the peripheral USB port on the Controller.



**3**

#### 3.3.2 Direct connection via Ethernet

The Ethernet port on the computer is connected directly to the Ethernet port on the Controller.

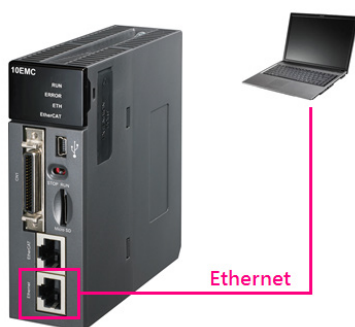

---

## Chapter 4 Operating ISPSoft

### Table of Contents

<b>4.1</b>	<b>Quick Start .....</b>	<b>4-2</b>
4.1.1	Example .....	4-2
4.1.2	Hardware.....	4-2
4.1.3	Program .....	4-3
<b>4.2</b>	<b>Procedures for Creating a Project in ISPSoft .....</b>	<b>4-3</b>
<b>4.3</b>	<b>Creating a Project.....</b>	<b>4-4</b>
<b>4.4</b>	<b>Hardware Configuration .....</b>	<b>4-5</b>
4.4.1	Configuring a Module.....	4-5
4.4.2	Setting the Parameters in a CPU and a Module .....	4-7
4.4.3	Setting Module Parameters .....	4-9
4.4.4	Setting PLC Parameters .....	4-16
<b>4.5</b>	<b>Creating a Program .....</b>	<b>4-18</b>
4.5.1	Adding a Ladder Diagram.....	4-19
4.5.2	Basic Editing—Creating a Contact and a Coil .....	4-21
4.5.3	Basic Editing—Inserting a Network and Typing an Instruction.....	4-24
4.5.4	Basic Editing - Selection of a Network and Operation.....	4-26
4.5.5	Basic Editing - Connecting a Contact in Parallel.....	4-28
4.5.6	Basic Editing—Editing a Comment.....	4-29
4.5.7	Basic Editing—Inserting an Applied Instruction .....	4-30
4.5.8	Basic Editing—Creating a Comparison Contact and Typing a Constant .....	4-32
4.5.9	Writing a Program.....	4-33
4.5.10	Checking and Compiling a Program .....	4-34
<b>4.6</b>	<b>Testing and Debugging a Program.....</b>	<b>4-35</b>
4.6.1	Creating a Connection .....	4-35
4.6.2	Downloading a Program and Parameters.....	4-38
4.6.3	Connection Test.....	4-40
4.6.4	Setting a Real-time Clock.....	4-46

## 4.1 Quick Start

The section provides a simple example, and leads users to create a traditional ladder diagram in ISPSOft in a short time. In order to help users quickly understand the functions provided by ISPSOft, and create a traditional ladder diagram, programming concepts related to IEC 61131-3 are not introduced in this section. For example, POU, function blocks, variables, and etc. are not introduced. The concepts related to IEC 61131-3 will be introduced in the following chapters.

### 4.1.1 Example

When the equipment operates, the parts on the conveyer are conveyed from left to right. If a sensor senses that a part is under an injector, the PLC will send a trigger signal to the injector, and the injector will injects the glue. How long the part will be injected is set externally, and is not controlled by the program in the PLC. However, the program in the PLC must be able to turn the trigger signal OFF so that the trigger signal can be sent next time. There are two injectors above the conveyer, and the two injectors inject glue in the same way.

Besides, there is a sensor at the left side of the conveyer. When a part passes the sensor, the sensor value increases by one increment. If the sensor value is 100, the internal completion flag will be set to ON. The state of the flag can be used by other procedures later. However, the use of the state of the flag is not introduced in this example.

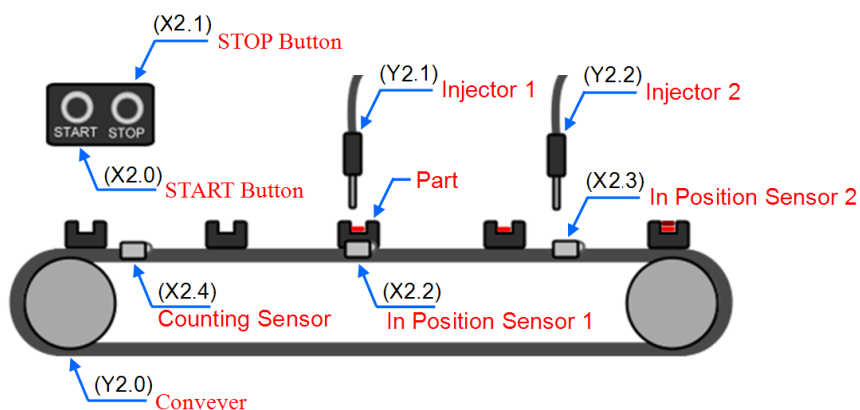

### 4.1.2 Hardware

In this example, the CPU module used is **AHxxEMC-5A**, the digital I/O module used is **AH16AP11R-5A**, and the backplane used is **AHBP05M2-5A**. The table below is an I/O allocation table.

Type	ID	Description
Digital input	X2.0	START button
Digital input	X2.1	STOP button
Digital input	X2.2	In position sensor 1
Digital input	X2.3	In position sensor 2
Digital input	X2.4	Counting sensor
Digital output	Y2.0	Conveyer
Digital output	Y2.1	Trigger signal for injector 1
Digital output	Y2.2	Trigger signal for injector 2

### 4.1.3 Program

- (1) When the START button (X2.0) is turned from OFF to ON, the internal operation flag is set to ON, and the conveyer (Y2.0) starts to run. When the STOP button (X2.1) is turned from OFF to ON, an error occurs (the error flag is ON), the operation flag is reset to OFF, and the conveyer stops running.
- (2) When in position sensor 1 (X2.2) is ON, the trigger signal for injector 1 (Y2.1) is set to ON. When in position sensor 1 is OFF, the trigger signal for injector 1 is reset to OFF.
- (3) When in position sensor 2 (X2.3) is ON, the trigger signal for injector 2 (Y2.2) is set to ON. When in position sensor 2 is OFF, the trigger signal for injector 2 is reset to OFF.
- (4) When the counting sensor (X2.4) is turned from OFF to ON, the sensor value increases by one increment. If the sensor value is larger than or equal to 100, the internal completion flag will be set to ON.

## 4.2 Procedures for Creating a Project in ISPSOft

The procedures for creating a project in ISPSOft is as follow. You can adjust the procedure according to the practical application and their habits.

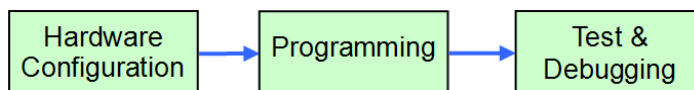

### ● Hardware configuration

You can set the parameters such as a range of latched devices, set the parameters for data exchange, and set a port number in a PLC. Besides, you have to configure modules used with an AHxxEMC-5A, and set the parameters in these modules.

### ● Programming

After you write a program in ISPSOft, you can compile the program. If the compiling of a program is unsuccessful, the messages in the **Compile Message** page can lead users to the places where errors occur to check the program code.

### ● Test and debugging

You can download a program which is compiled, a hardware configuration, and a network configuration to a PLC. Besides, you can test and debug the program online by means of the functions provided by ISPSOft.

Because the example introduced in this chapter does not discuss a network configuration, only the following procedure is carried out. The procedure will be introduced in the following section.

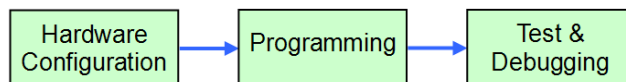

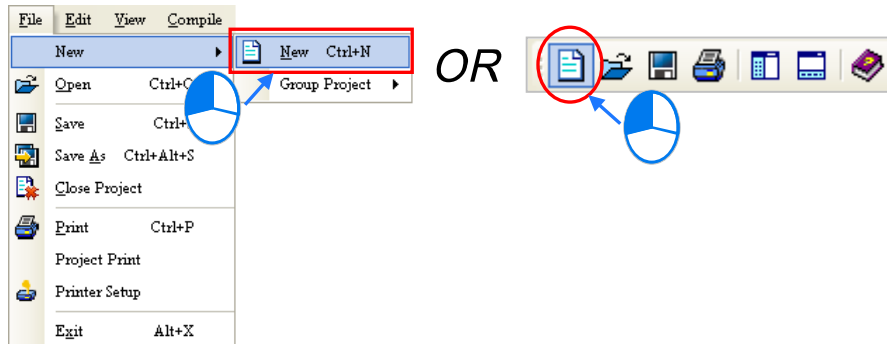

### 4.3 Creating a Project

After ISPSOft is started, you can click the **File** menu, point to **New**, and click **New** to create a new project. You can also create a new project by clicking  on the toolbar after ISPSOft is started.

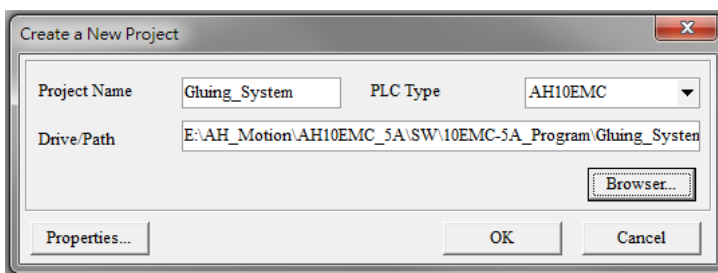

In the **Create a New Project** window, type a project name in the **Project Name** box and a path in the **Drive/Path** box, select a PLC in the **PLC Type** drop-down list box, and click **OK**. (The PLC used in this example is AHxxEMC-5A.)



After the project is created successfully, a project management area will appear at the left side of the main screen. The relation between the items listed in the project management area is represented by a hierarchical tree structure. If the project management area does not appear, you can click **Workspace** on the **View** menu, or click  on the toolbar.

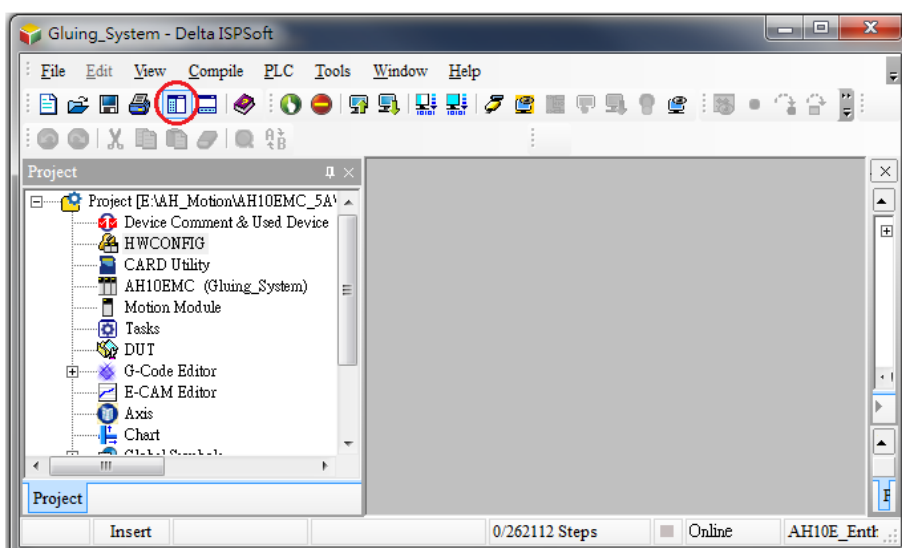

## 4.4 Hardware Configuration

After you double-click **HWCONFIG** in the project management area, the **HWCONFIG** window will appear.

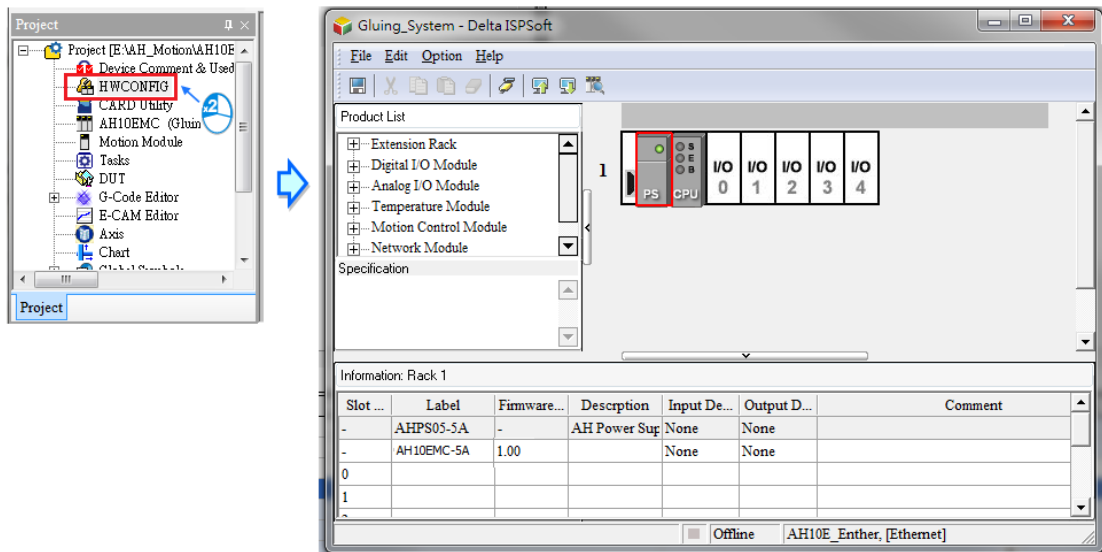

### 4.4.1 Configuring a Module

In the **HWCONFIG** window, there is a five-slot backplane on which a CPU module and a power supply module are installed. However, the backplane used in this example is the three-slot backplane **AHBP03M2-5A** on which the digital I/O module **AH16AP11R-5A** is installed.

If you want to replace the backplane, you can right-click the left side of the rack in the system configuration area, click **Replace** on the context menu, and double-click **AHBP03M2-5A** in the Rack Selection window.

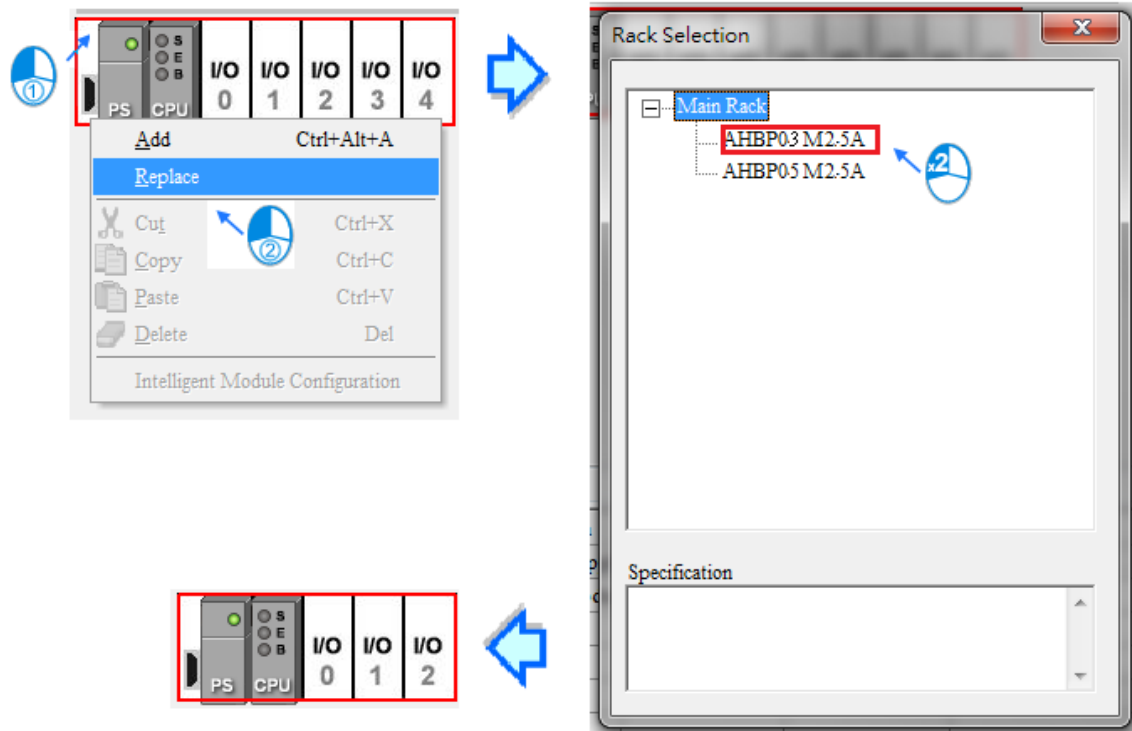



Unfold the **Digital I/O Module** section on the product list, find **AH16AP11R-5A**, and drag the module to a vacant slot on the backplane in the system configuration area. After the module is added successfully, the related information and the devices assigned to the module will be listed in the table at the bottom of the window.

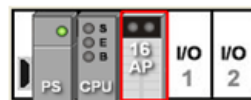
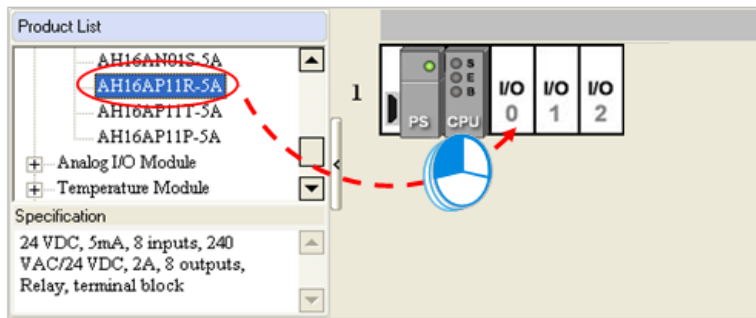

Information: Rack 1

Slot No.	Label	Firmware...	Description	Input Device ...	Output Device...	Comment
-	AHPS05-5A	-	AH Power Supply Module	None	None	
-	AH10EMC-5A	1.00	Basic CPU module building	None	None	
0	AH16AP11R-5A	-	8 x DI VDC, 8 x DO VAC/VD	X0.0 ~ X0.15	Y0.0 ~ Y0.15	
1						

4

The system automatically assigns devices to a module which is added. If the devices assigned to a module do not conform to what is expected, you can click the **Input/Output Device Range** cell for the module, click **...** in the cell, and type a device address in the **Manual Assignment** window.

Information: Rack 1

Slot No.	Label	Firmware...	Description	Input Device ...	Output Device...	Comment
-	AHPS05-5A	-	AH Power Supply Module	None	None	
-	AH10EMC-5A	1.00	Basic CPU module building	None	None	
0	AH16AP11R-5A	-	8 x DI VDC, 8 x DO VAC/VD	X0.0 ~ X0.15 ...	Y0.0 ~ Y0.15	
1						



**Manual Assignment**

Input Device Range

Device X

Number

Length 1

OK

Cancel

#### 4.4.2 Setting the Parameters in a CPU and a Module

After **AH16AP11R-5A** is configured, you can set the parameters in the CPU module and the parameters in the extension module. After you double-click the CPU module or the extension module, a corresponding window will appear.

After the CPU module is double-clicked, the **PLC Parameter Setting** window will appear. You can click the primary tabs at the top of the window, and the secondary tables at the bottom of the window to set the parameters. In this example, you only need to define the name of the CPU module.

After you click the **CPU** tab at the top of the window, and the **Name** tab at the bottom of the window, you can type a name in the **Name** box. You will find the default name in the **Name** box is the same as the project name. Delete the default name, type "Main\_Controller" in the **Name** box, and click **OK**.

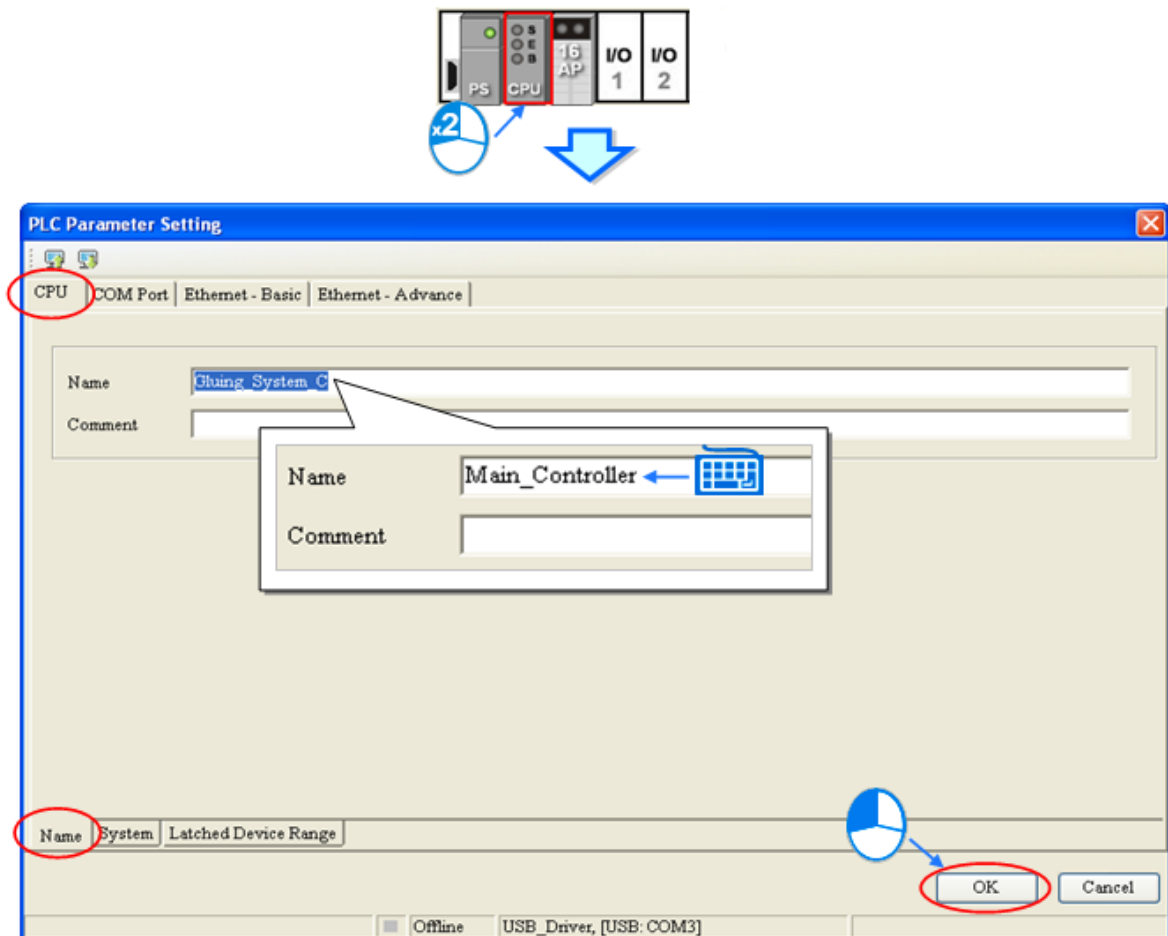

After you double-click AH16AP11R-5A, the **Parameter Setting** window will appear.

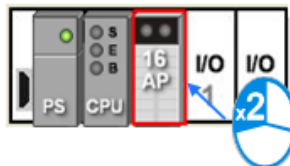

After the **Parameter Setting** window is opened, you can view the information related to the module. You can select the parameter type at the left side of the window, and then set the parameter in the table at the right side of the window.

In this example, the default values are retained. Therefore, the step of setting the parameter in AH16AP11R-5A is skipped.

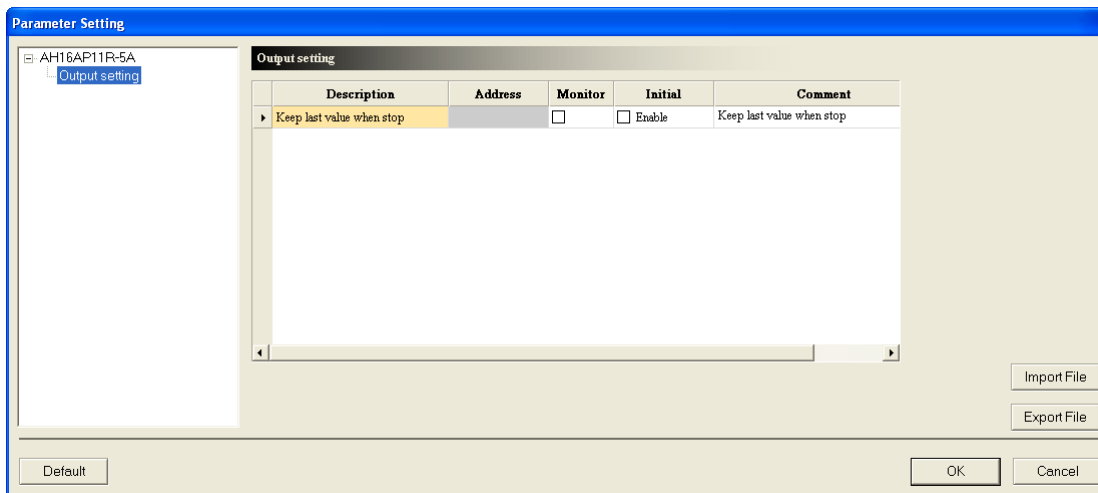
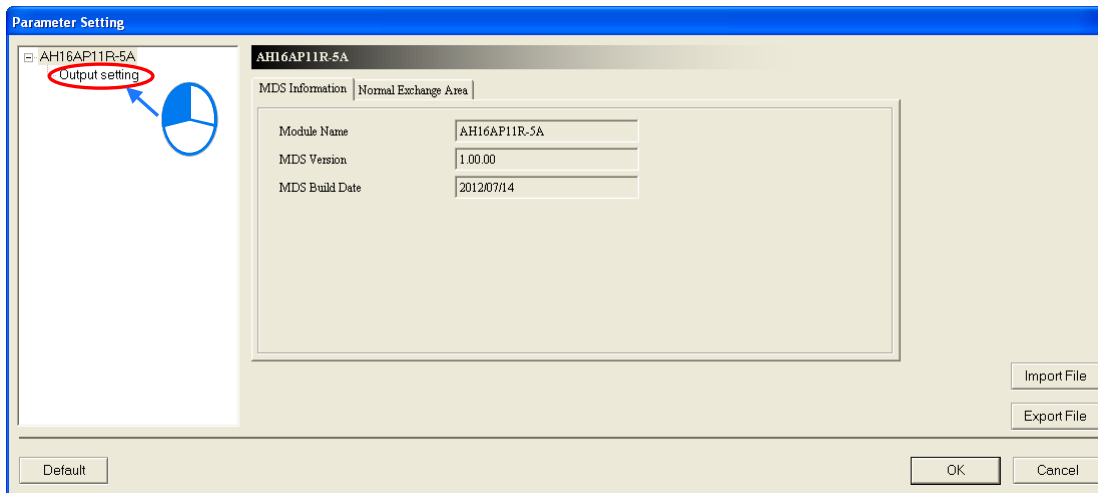

4

The hardware configuration is not complete until the parameters in the CPU module and AH16AP11R-5A are set. However, the configuration and the setting must be downloaded to the CPU module so that you can take effect. The configuration and the setting are saved here, and will be downloaded with the program in the project later.

If you want to save the configuration and the setting, you can click **Save** on the **File** menu, or  on the toolbar. After the configuration and the setting are saved, you can close the **HWCONFIG** window.

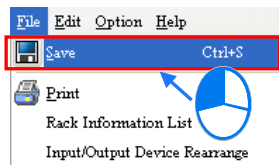

OR

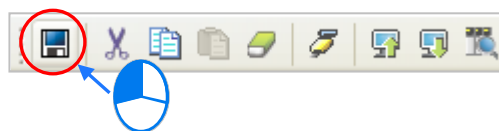

**\*Note: Please refer to section 4.4 for more information about HWCONFIG.**

### 4.4.3 Setting Module Parameters

Setting Parameters for Analog Input/Output Modules

(1) AH04AD-5A

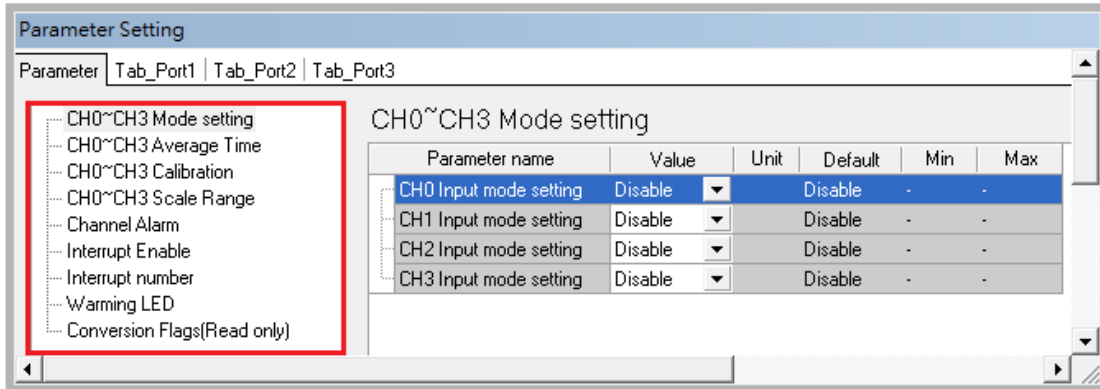

(2) AH08AD-5B

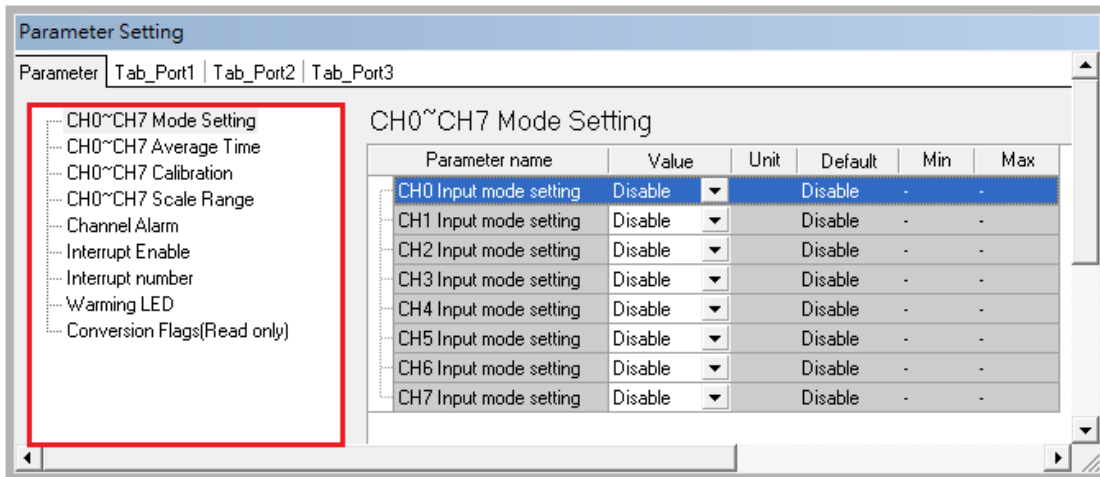

(3) AH08AD-5C

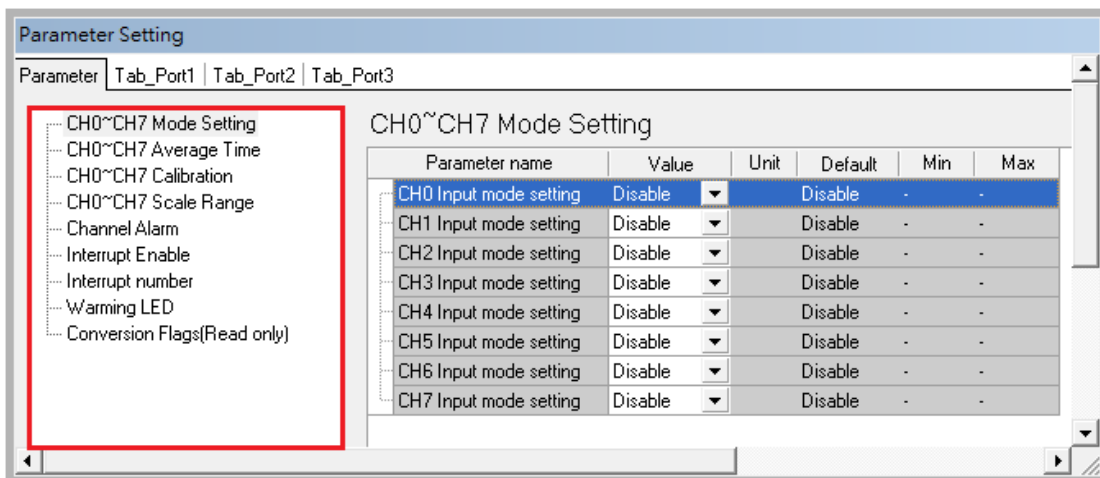

(4) AH04DA-5A

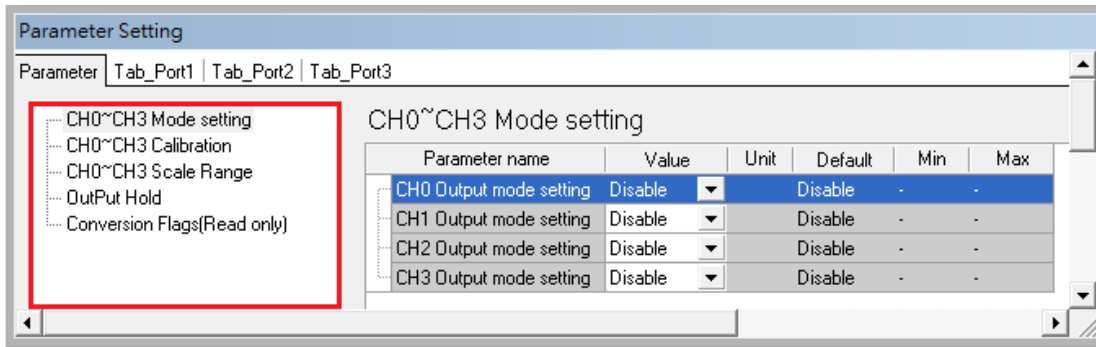

(5) AH08DA-5B

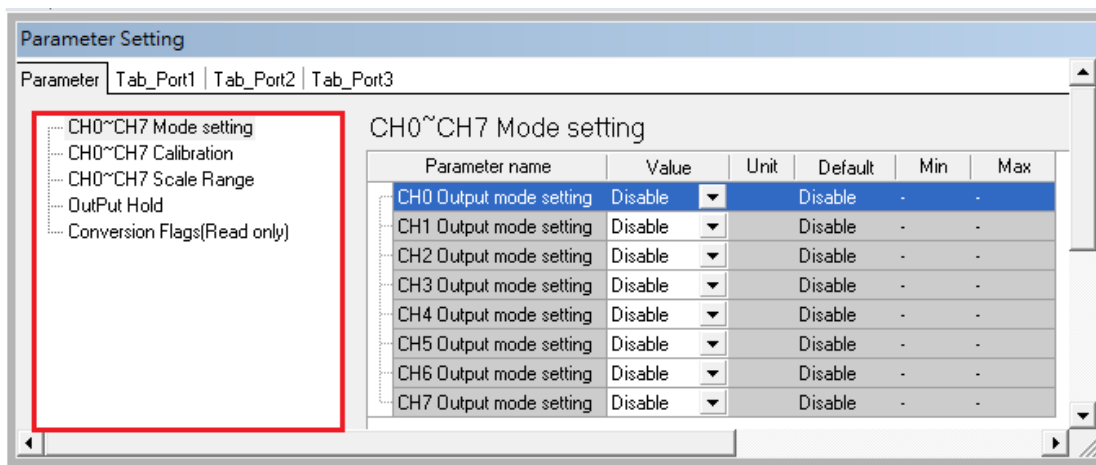

(6) AH08DA-5C

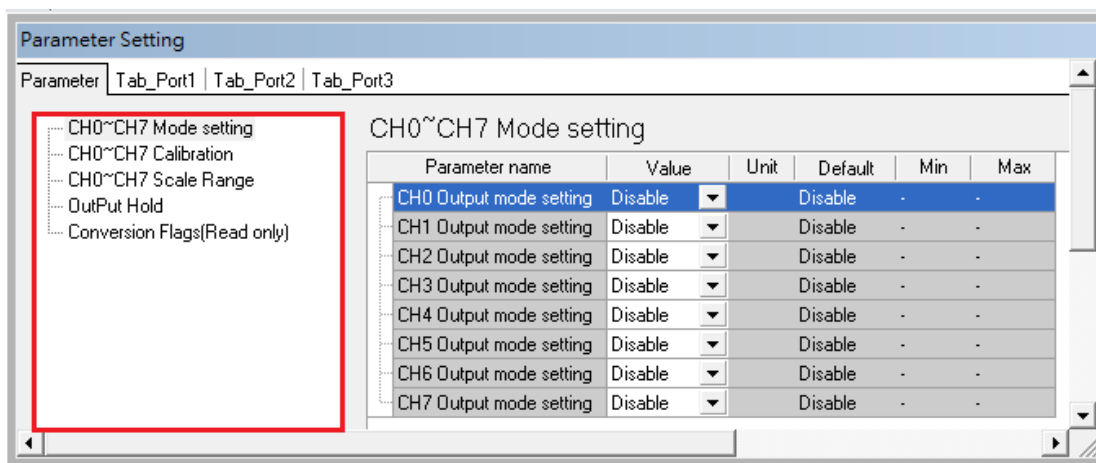

4

## (7) AH06XA-5A

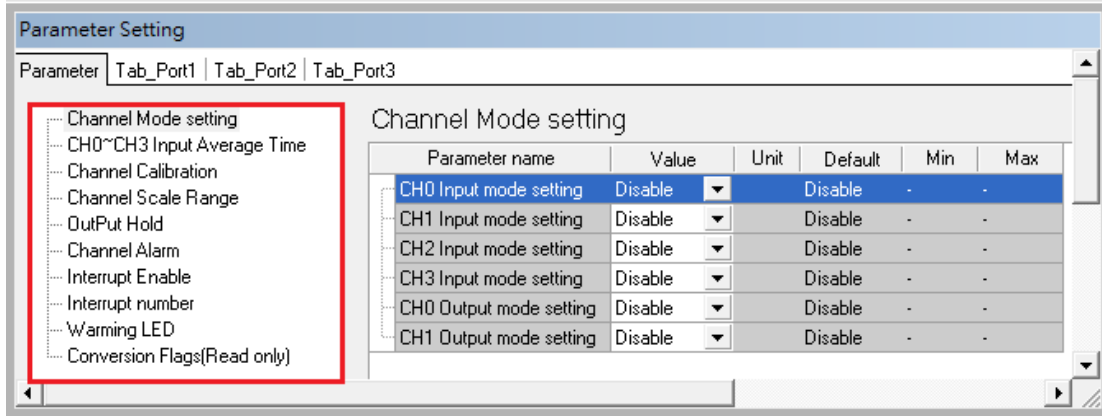

Please refer to **AH500 Module Manual** for more information about setting parameters.

## Setting Parameters for Temperature Modules

## (1) AH04PT-5A

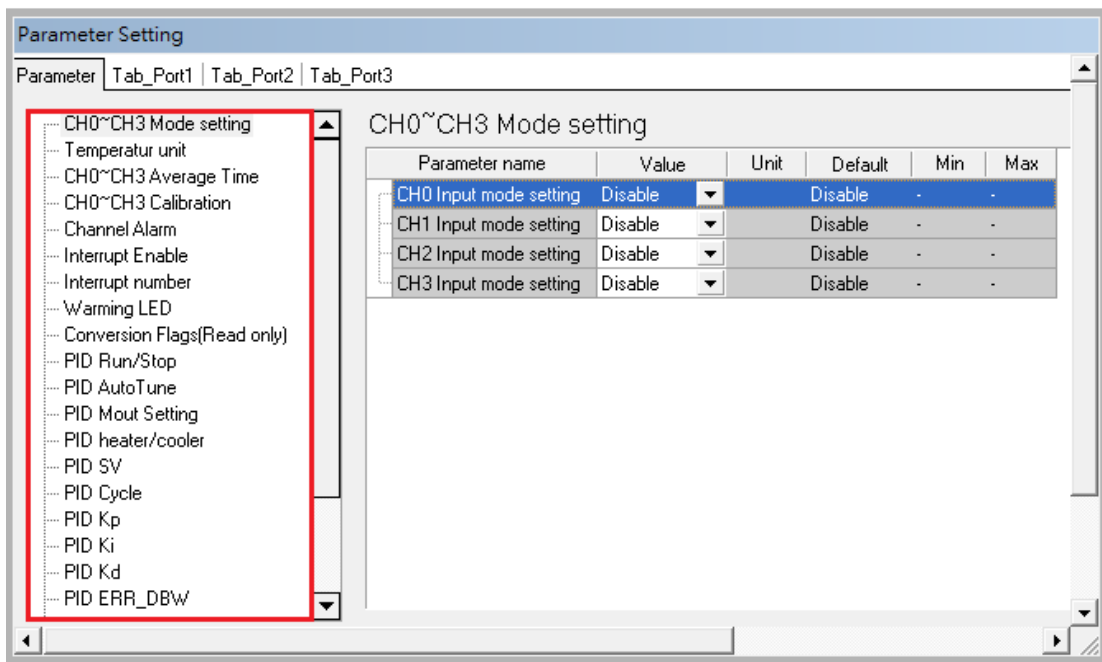

(2) AH08PTG-5A

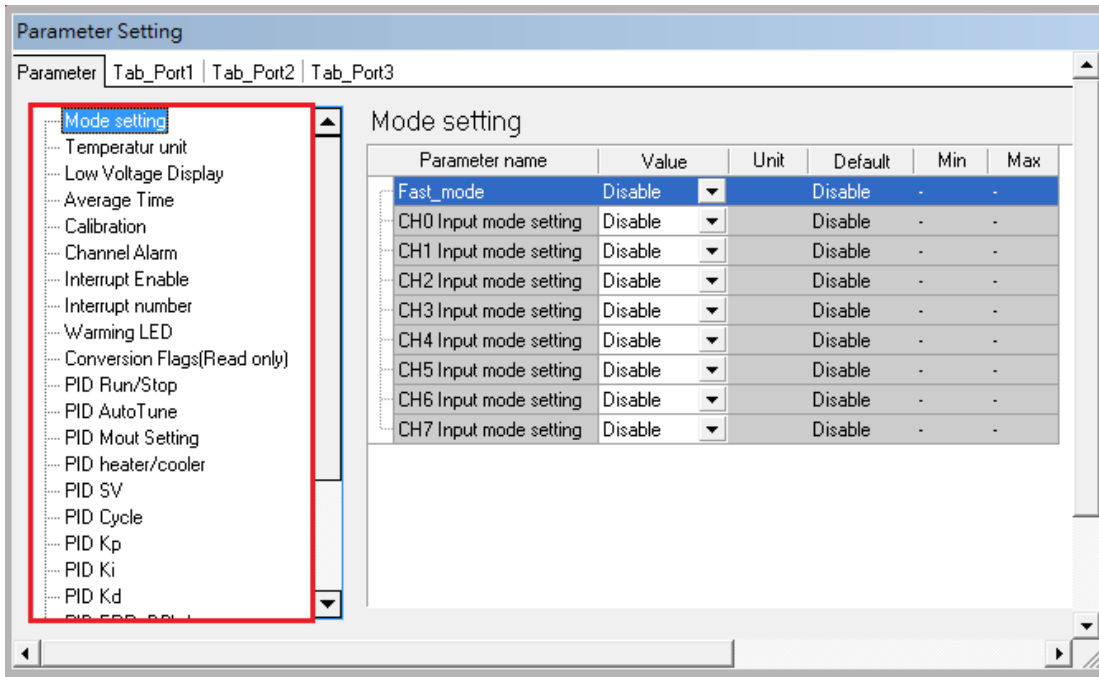

(3) AH04TC-5A

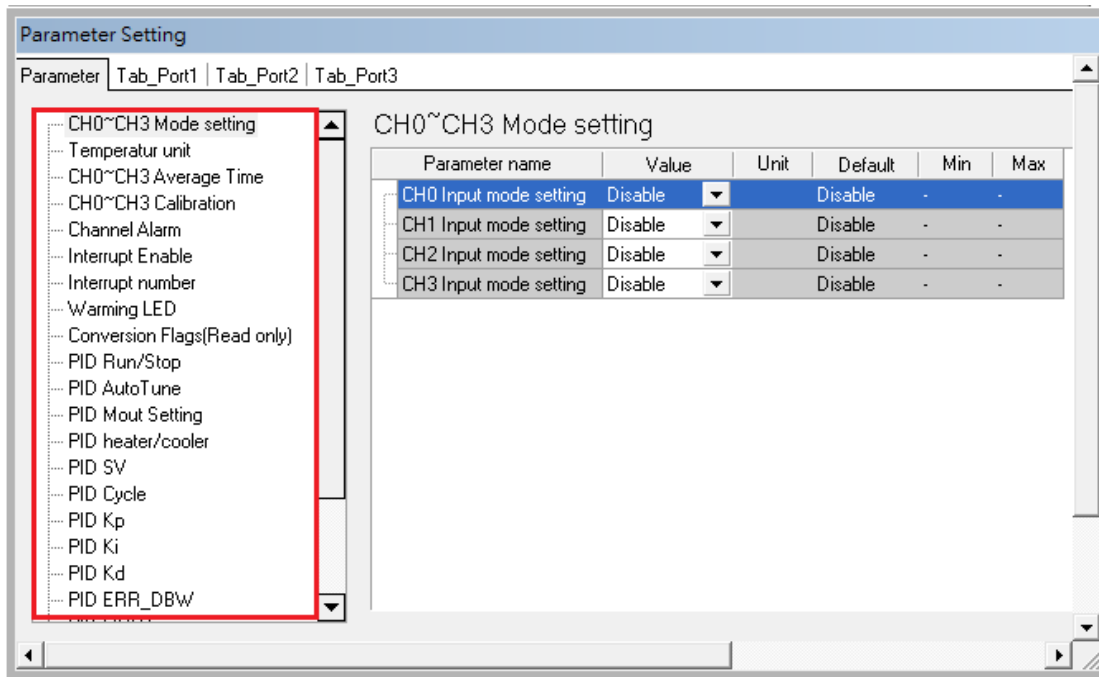

4

## (4) AH08TC-5A

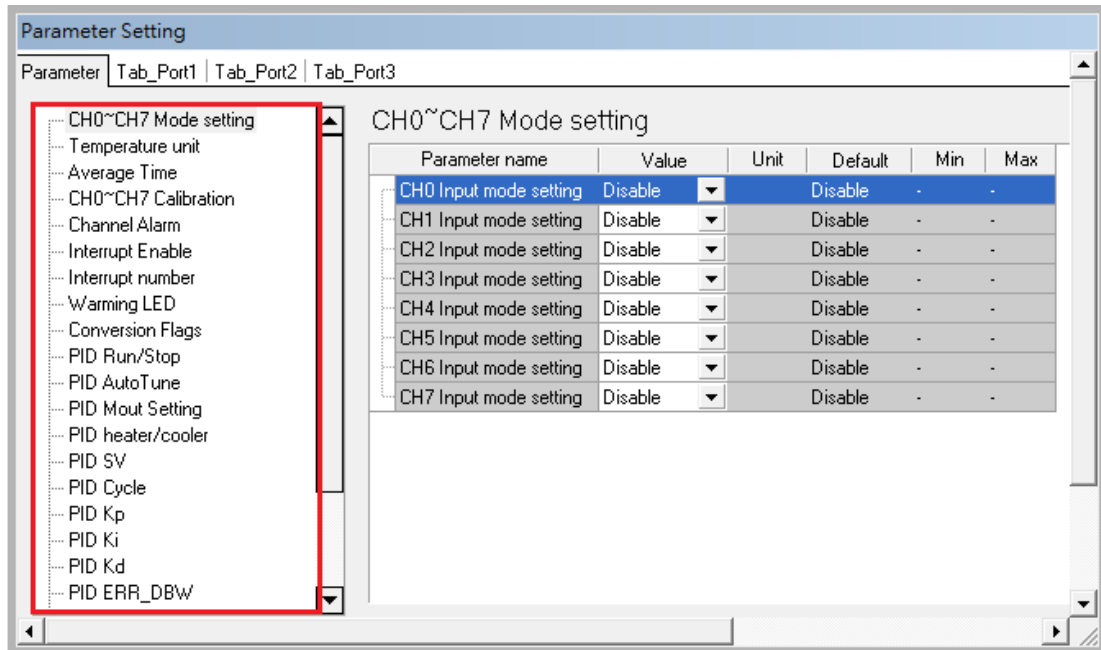

Please refer to *AH500 Module Manual* for more information about setting parameters.

4

## Setting Parameters for Network Modules

## (1) AH10COPM-5A

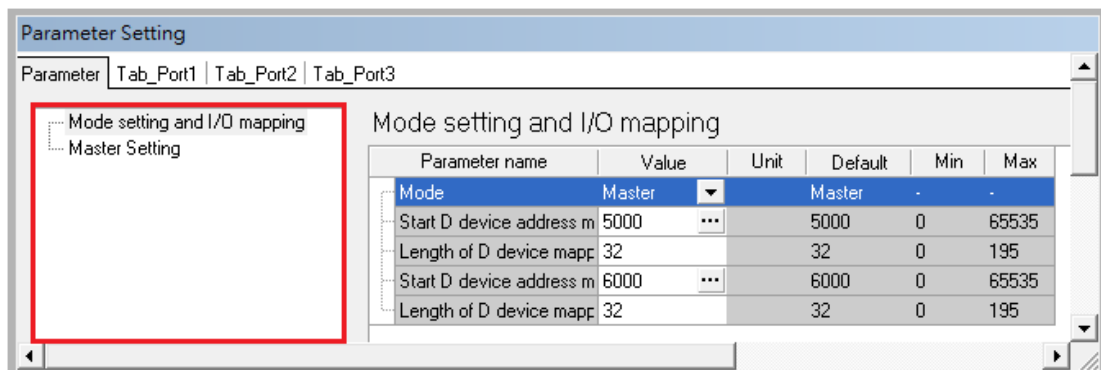



(2) AH10SCM-5A

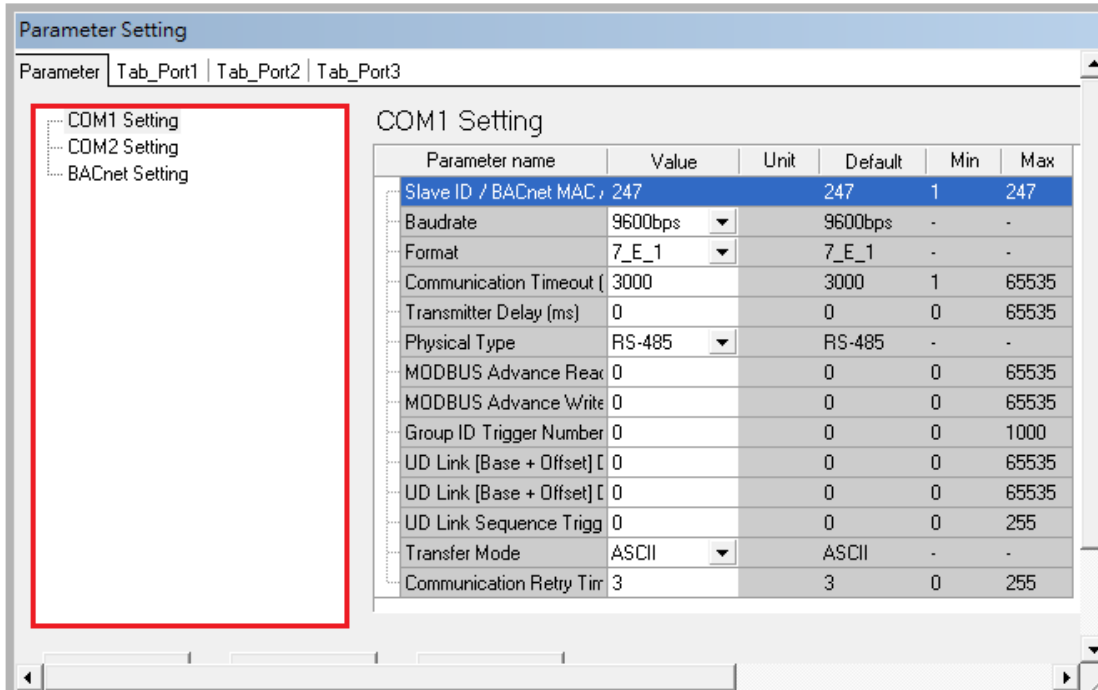

Please refer to **AH500 Module Manual** for more information about setting parameters.

Setting Parameters for Motion Control Modules

(1) AH04HC-5A

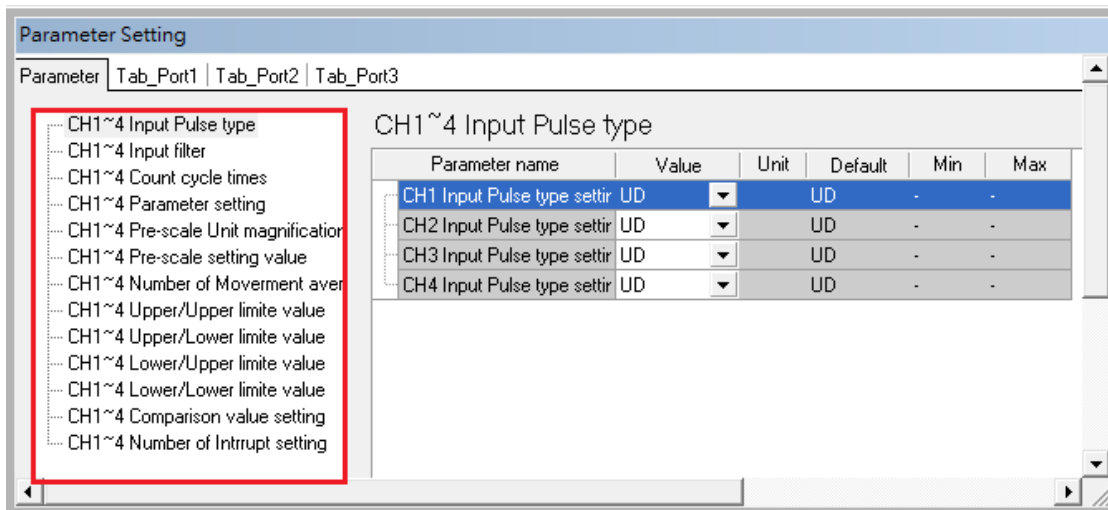

(2) AH02HC-5A

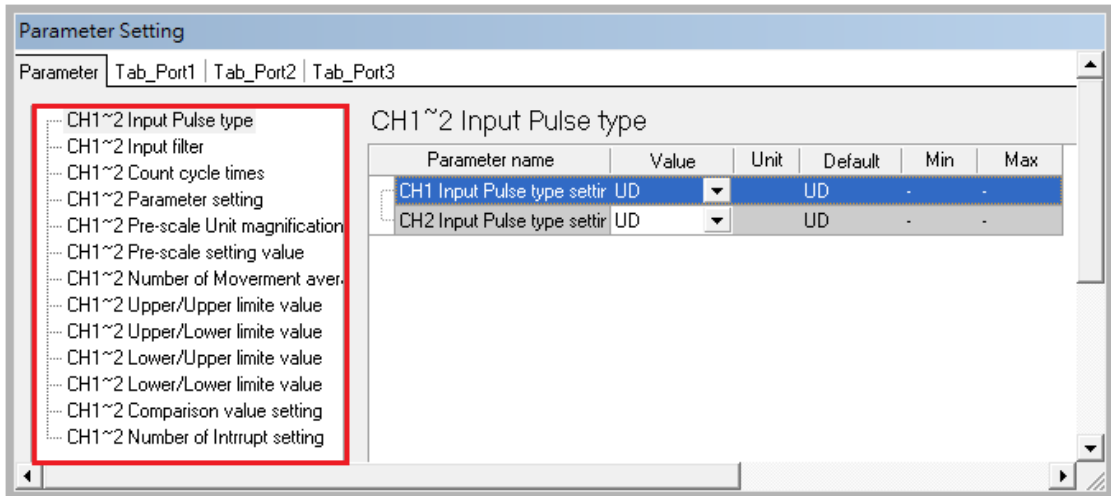

(3) AH05PM-5A

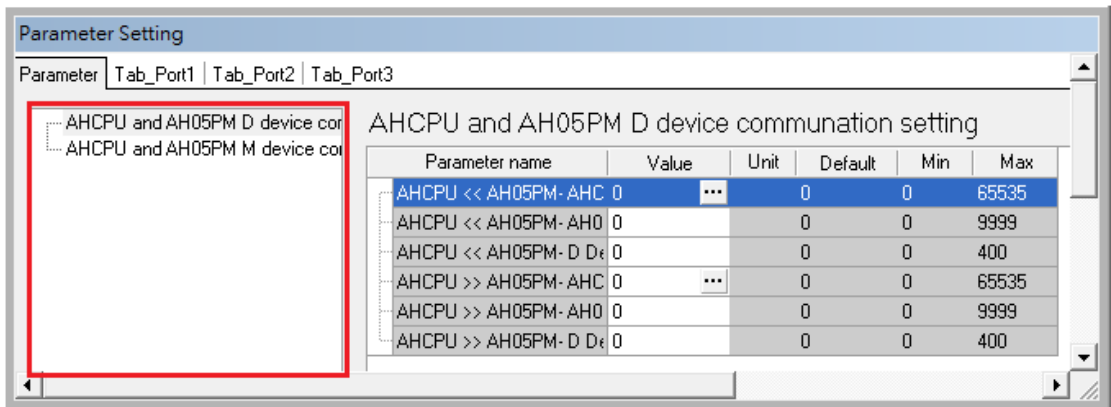

4

(4) AH10PM-5A

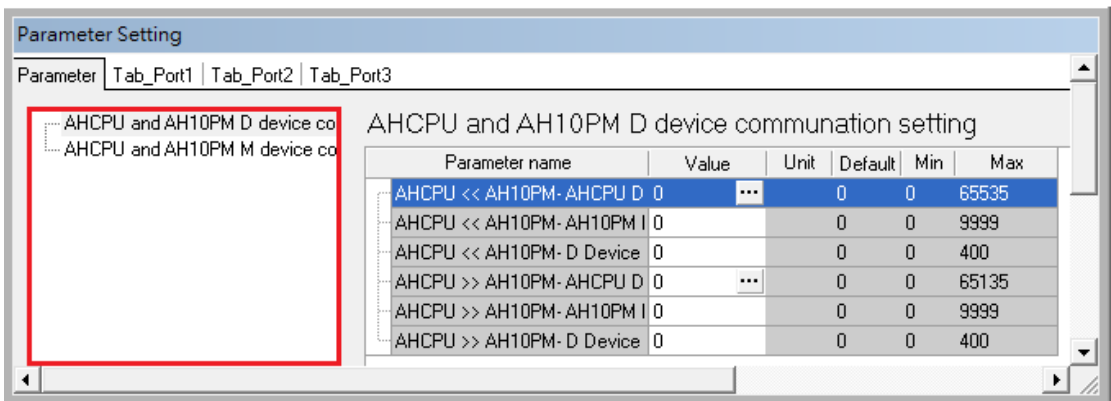

(5) AH15PM-5A

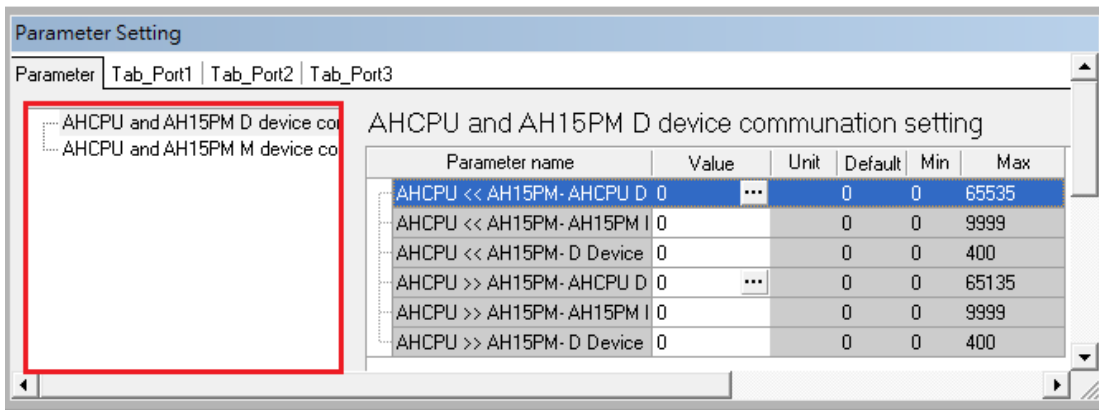

(6) AH20MC-5A

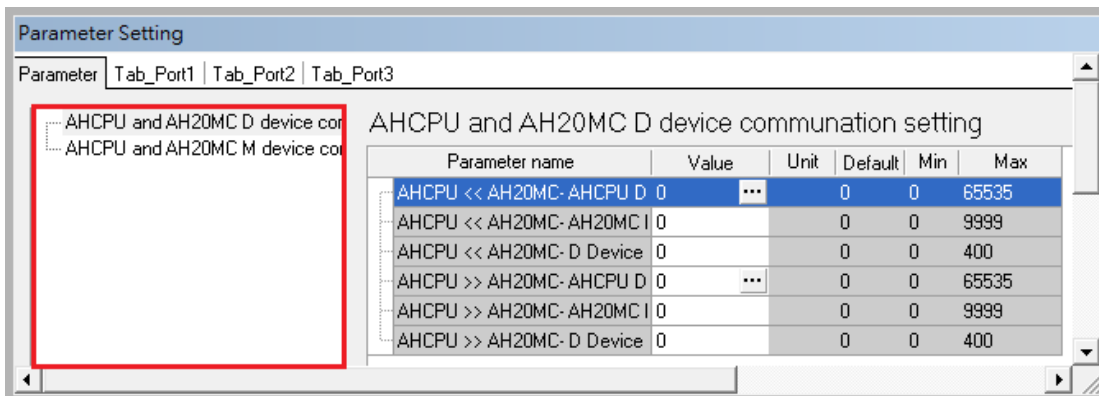

Please refer to *AH500 Module Manual* for more information about setting parameters.

## 4.4.4 Setting PLC Parameters

### 4.4.4.1 IO Input Filter

Users can set the IO input filter to filter out unnecessary signal. There are two methods to set the filter:

(1) X Input Single Filter Time

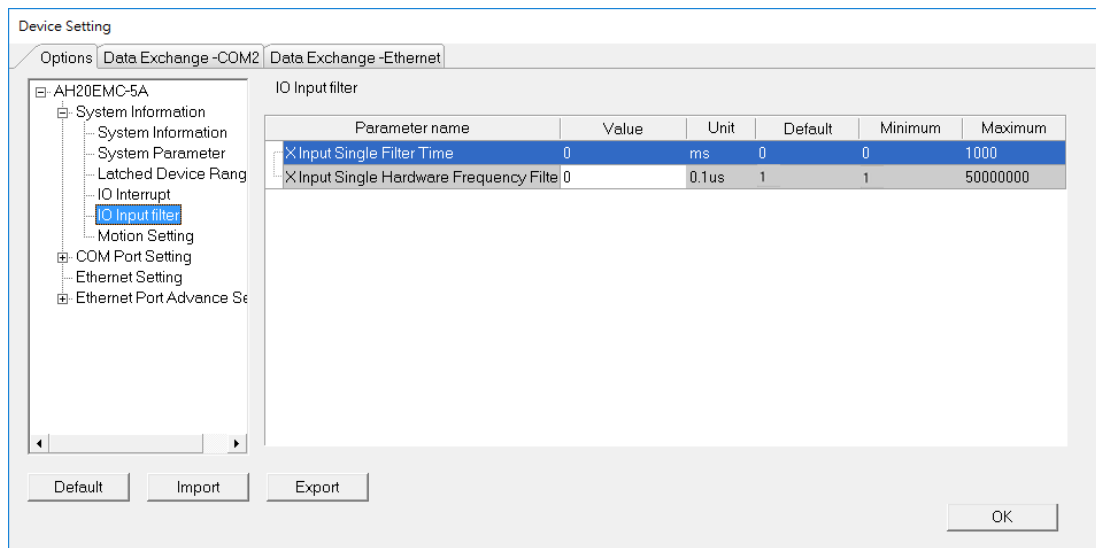

- Setting up the responding time for the input filter; setting unit is ms, in the range of 0~1000. The responding time less than 1000 ms will be filtered out.
- Example: the responding time for X input is set to 10 ms: M100 will stay ON, when the X0.0 signal lasts for more than 10ms.

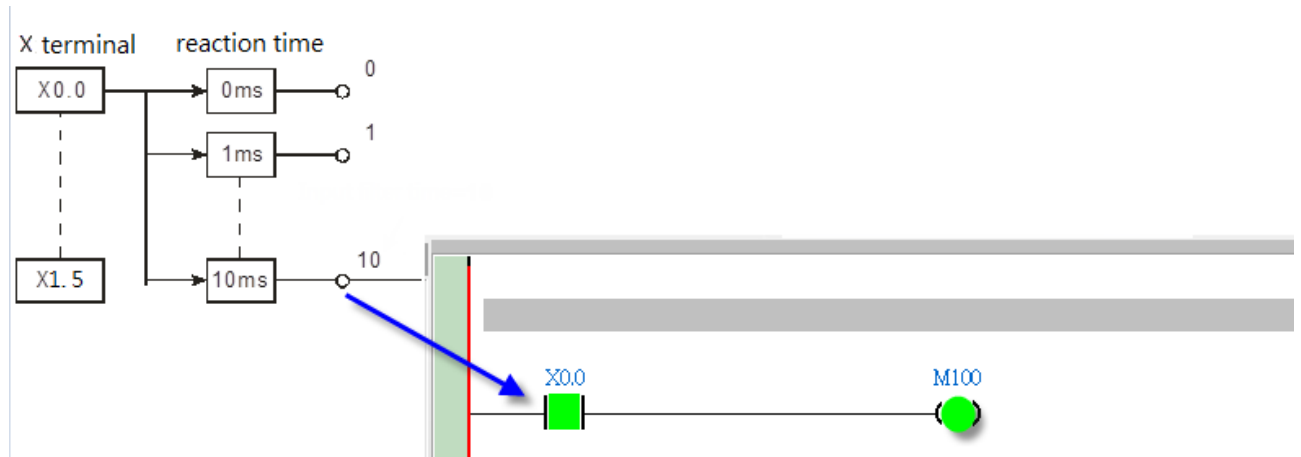

## (2) X Input Single Hardware Frequency Filter

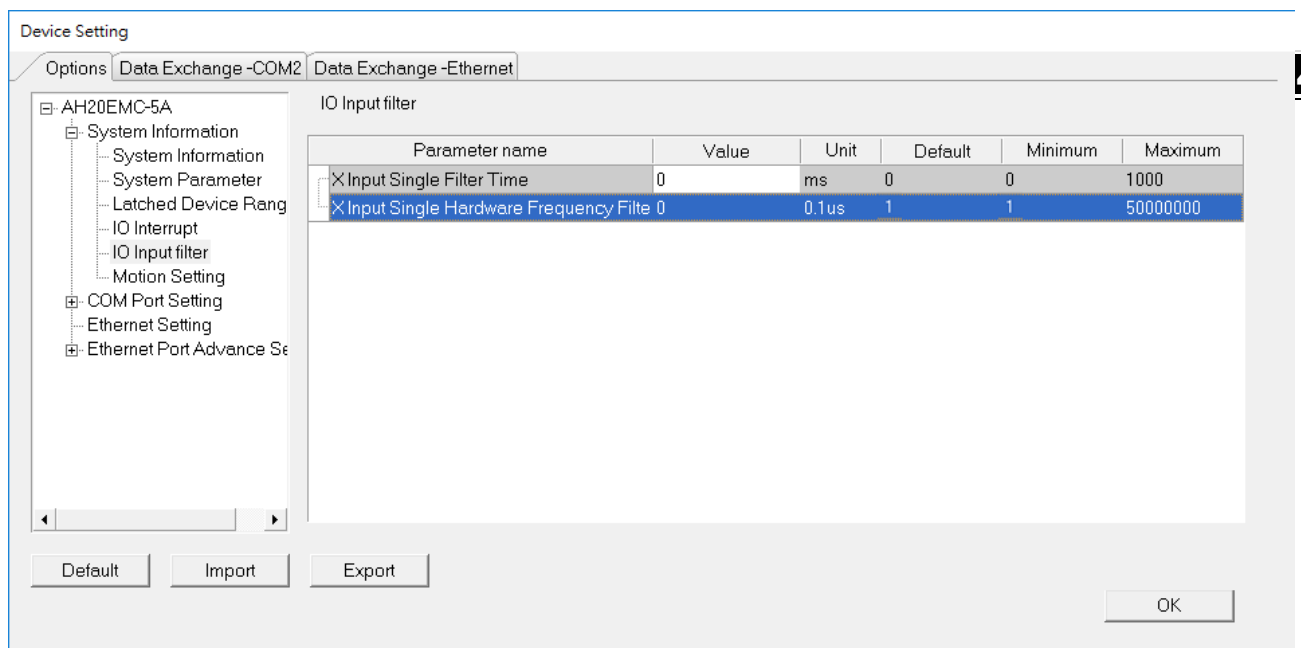

The hardware frequency filter time should be set less than the Duty On time of the X input. The setting unit is 0.1 $\mu$ s, in the range of 1~50000000.

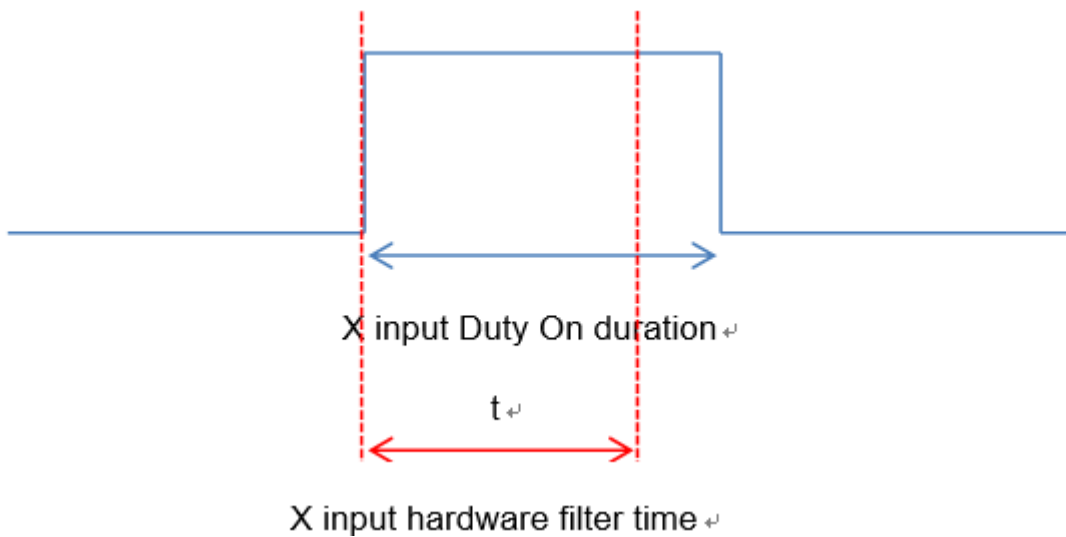

- The formula of filter frequency and time:  
 Filter frequency (f)\*= 1/2(filter time t) (Hz): refer to the table below. If the input frequency is higher than it is stated in the range below. The signal will be filtered out.

t (0.1u)	f (Hz)
1	5M
25	200K
100	50K
250	20K
1000	5K
2500	2K
10000	500

\*The filter frequency should be corresponding to the response characteristic, refer to AH Motion Controller Hardware Manual for more details.

- This function is for DFB\_Capture2, DFB\_Hcnt, DFB\_HTmr, DFB\_Compare, and the X inputs used in the IO interrupts.

## 4.5 Creating a Program

The following sections will lead users to create a traditional ladder diagram in ISPSOft. The contents of the following sections include creating a POU, editing a traditional diagram, and compiling a program. You are expected to equip yourselves with the basic abilities to create a traditional ladder diagram in a short time.

### 4.5.1 Adding a Ladder Diagram

- (1) Right-click **Programs** in the project management area, point to **POU** on the context menu, and click **New...**

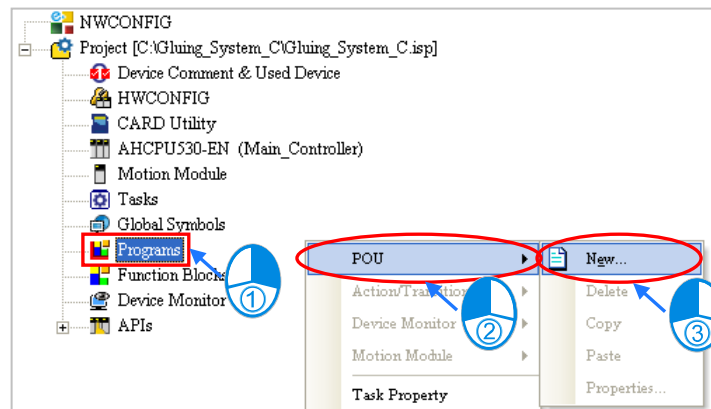

- (2) Type a program name in the **POU Name** box, select the **Ladder Diagram (LD)** option button in the **Language** section, and retain the other default values. Click **OK** after the setting is complete. An item will be under **Programs** in the project management area. The item is a program organization unit (POU).

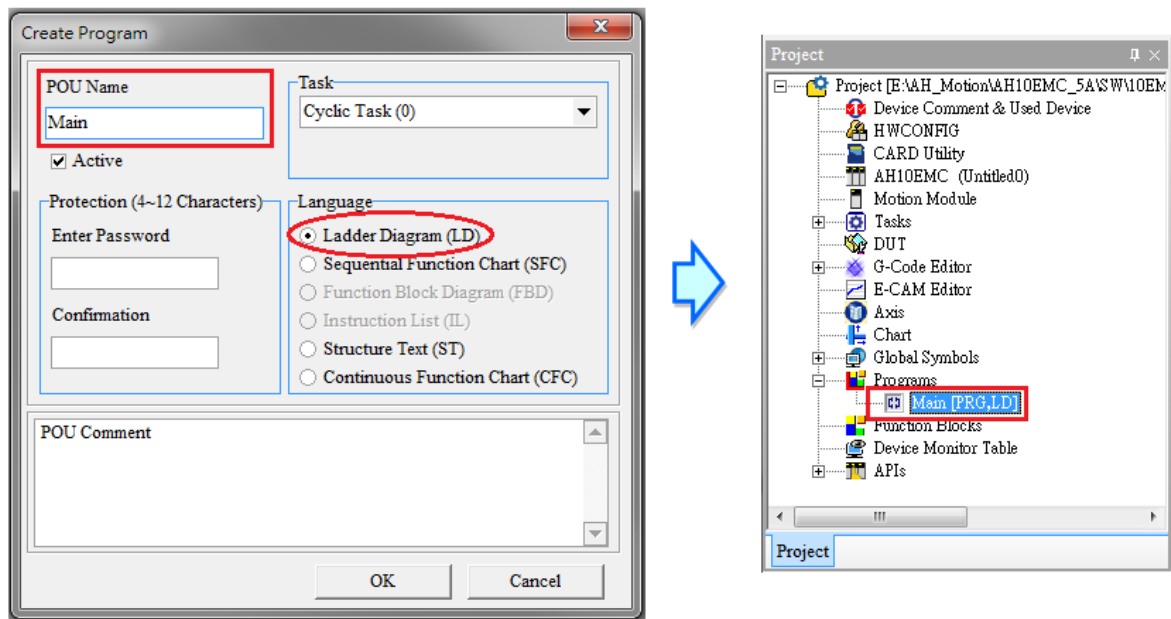

(3) After the POU is added, a program editing window will appear in the main working area.

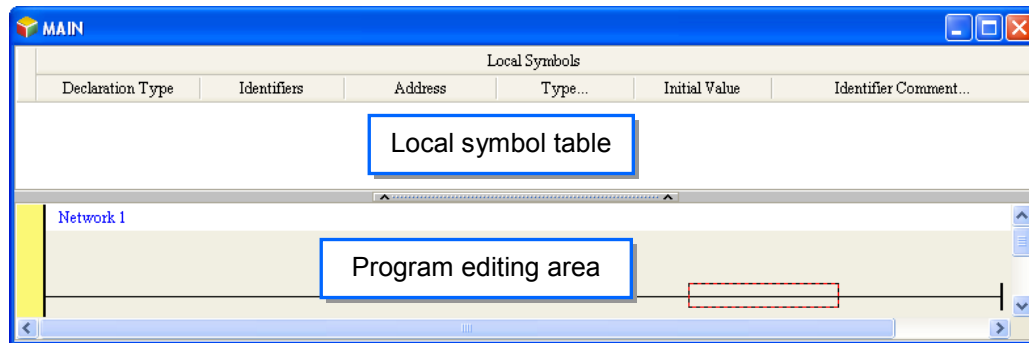

After the program editing window is opened, the corresponding toolbar will appear in the window. The functions are described below.



Icon	Keyboard shortcut	Function
	Shift+Ctrl+C	Displaying/Hiding the comments on the networks
	None	Displaying/Hiding the commands on the devices
	Shift+Ctrl+A	Activating/Inactivating the network selected
	Shift+Ctrl+B	Adding a bookmark to the network selected or deleting a bookmark from the network selected
	Shift+Ctrl+P	Going to the previous bookmarked position
	Shift+Ctrl+N	Going to the next bookmarked position
	Ctrl+I	Putting a network above the network selected
	Shift+Ctrl+I	Putting a network under the network selected
	ESC	Selection
	Typing an instruction	Inserting a contact
	Typing an instruction	Inserting a coil
	Typing an instruction	Inserting a comparison contact
	Typing an instruction	Selecting a type of comparison contact
	Typing an instruction	Inserting a block logic instruction (NP/PN/INV/FB_NP/FB_PN)
	Typing an instruction	Selecting a type of block logic instruction (NP/PN/INV/FB_NP/FB_PN)
	Shift+Ctrl+U	Inserting an instruction or a function block

\*. Please refer to section 4.5.3 for more information about typing an instruction.

### 4.5.2 Basic Editing—Creating a Contact and a Coil

- (1) Click  on the toolbar, and then move the mouse cursor to the red frame in network 1. The mouse cursor appears as a contact when the mouse cursor is moved to the left side of the red frame, the right side of the red frame, or the bottom of the red frame. Users can decide where to insert a contact. If a ladder diagram is edited, the mouse cursor must be near a position which is edited. Besides, an object inserted is arranged by the system automatically. Users can not move the object at will.

In this example, users do not need to decide where to insert the contact. Therefore, the mouse cursor can be near the red frame, and you can click the left mouse button.

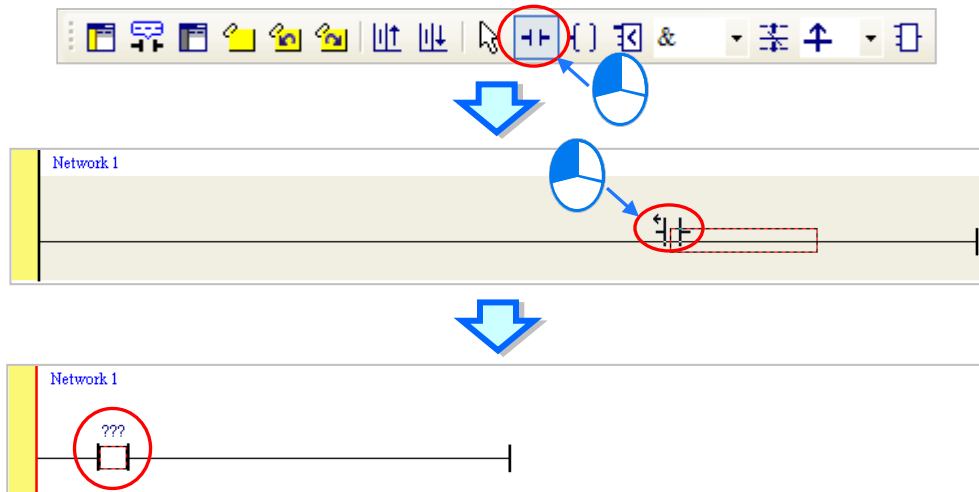

- (2) Click  on the toolbar, or press Esc on the keyboard. After the contact is double-clicked, a drop-down list will appear. The items on the drop-down list are **Normally Open**, **Normally Close**, **Rising-edge Trigger**, and **Falling-edge Trigger**. In this example, **Rising-edge Trigger** is selected.

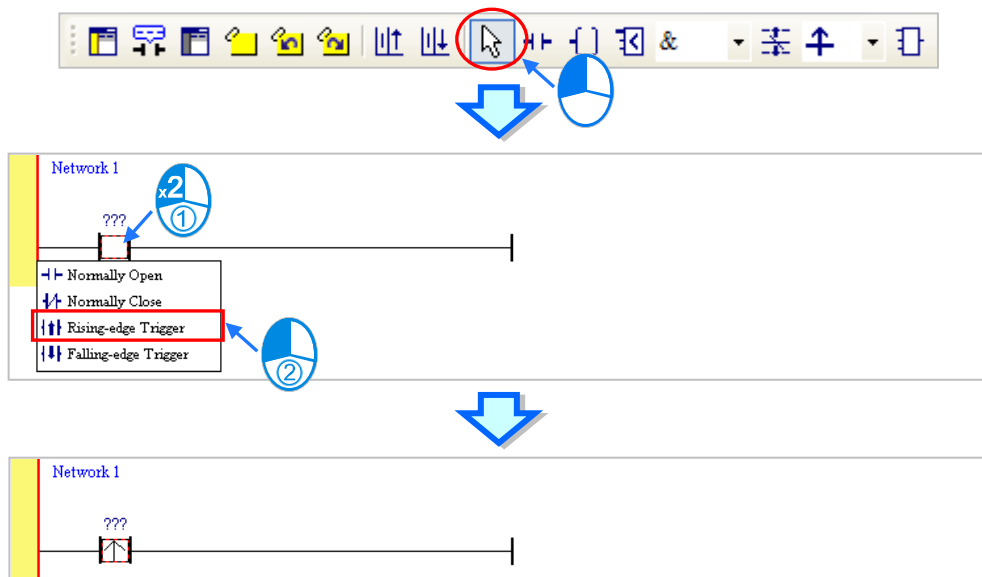



- (3) Click the line at the right side of the contact, click  on the toolbar, and move the mouse cursor to the red frame. Likewise, the mouse cursor appears as a coil when the mouse cursor is above or under the red frame. Users can decide where to insert the coil.

In this example, you do not need to decide where to insert the coil. Therefore, the mouse cursor can be near the red frame, and you can click the left mouse button.

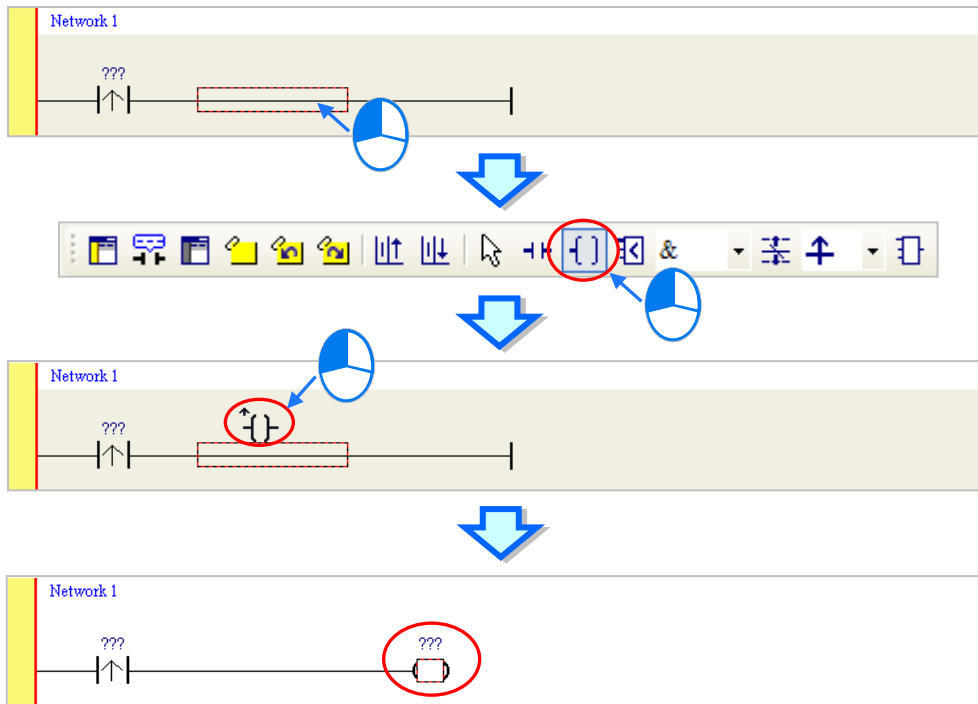

4

- (4) Click  on the toolbar, or press Esc on the keyboard. After the coil is double-clicked, a drop-down list will appear. The items on the drop-down list are **Out**, **Set**, and **Reset**. In this example, **Set** is selected.

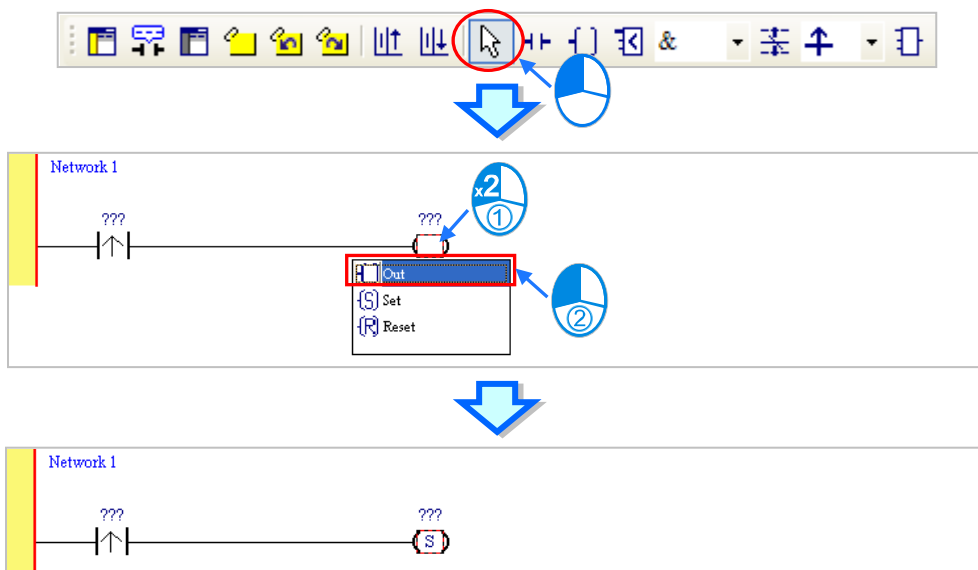

- (5) Click ??? above the contact, type a device address in the box, and press Enter on the keyboard to jump to the next box in the network. After a device address is typed in the box, you can press Esc on the keyboard to complete the editing. In this example, X0.0 is typed in the box for the contact, and M0 is typed in the box for the coil.

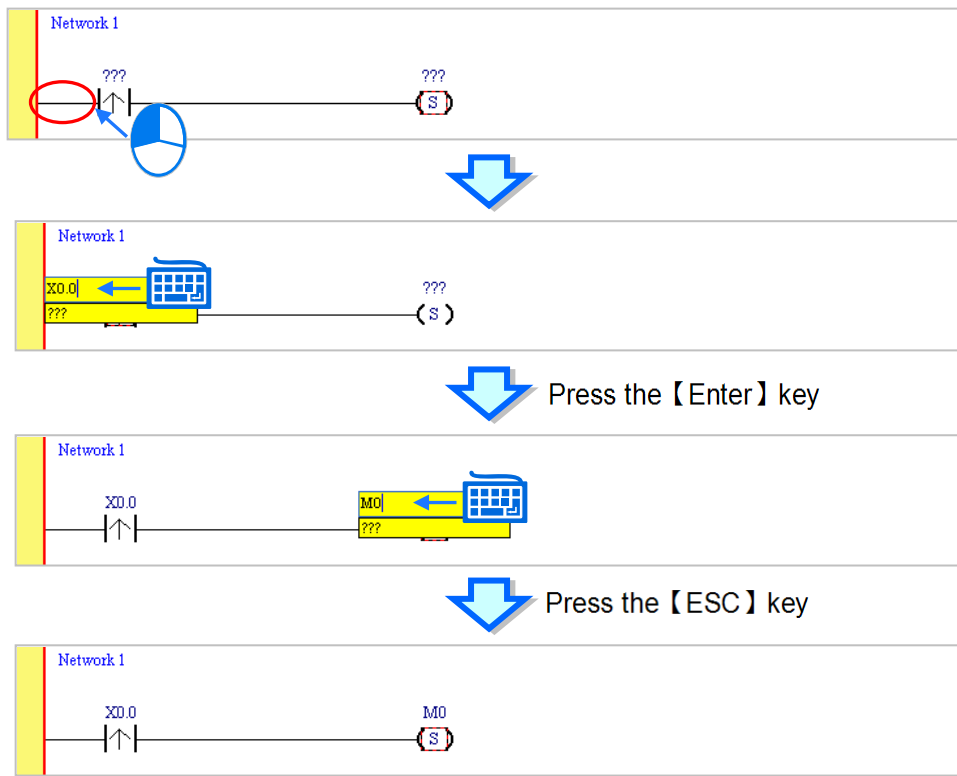



#### **Additional remark**

After you click a network and press Enter on the keyboard, you can edit a box. You can edit the next box in the network after you press Enter on the keyboard. Besides, the next network is selected after you press Tab on the keyboard. You can edit a box with the keyboard. After the editing is complete, you can press Enter on the keyboard to jump to the next box. If you want to end the editing, you can press Esc on the keyboard.

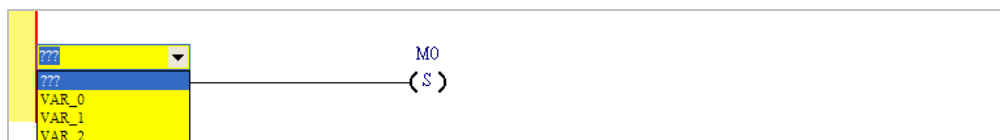

If you have declared symbols, you can click  in a box, or press Page Down on the keyboard when you edit the box. The symbols on the drop-down list are the symbols which can be assigned to the object. You can select a symbol by the mouse or the up/down key on the keyboard. Please refer to chapter 6 of ISPSoft User Manual for more information about symbols.

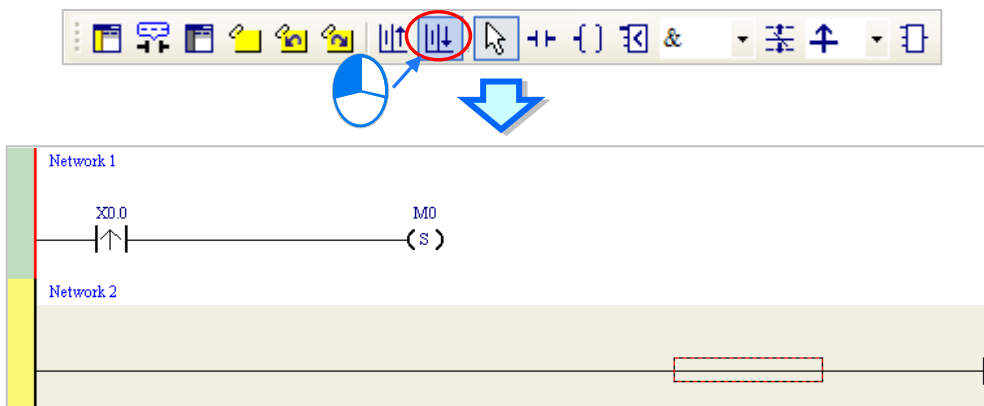

### 4.5.3 Basic Editing—Inserting a Network and Typing an Instruction

After  on the toolbar is clicked, a network will be under the network selected. After  on the toolbar is clicked, a network will be put above the network selected. In this example, a network is under network 1.



A contact and a coil can be created not only by clicking  and  on the toolbar, but also by typing instructions.

- (1) Click the line in network 2.

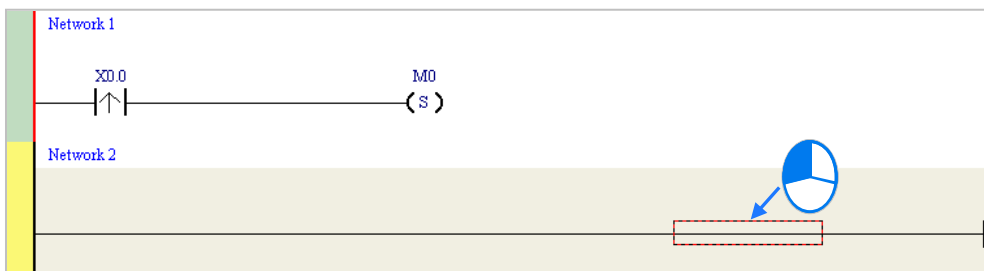

- (2) Type the IL instruction “LD M0”. (The instruction is case-insensitive.) As soon as the IL instruction is typed, a box which can be edited appears. After the typing of the IL instruction is complete, users can press Enter on the keyboard or click **OK** at the right side of the box.

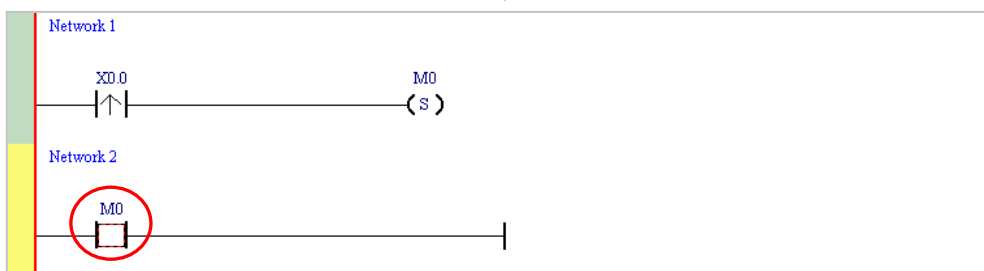
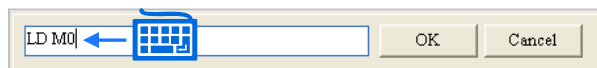

(3) Type the IL instruction “OUT Y0.0”, and write the program shown below.

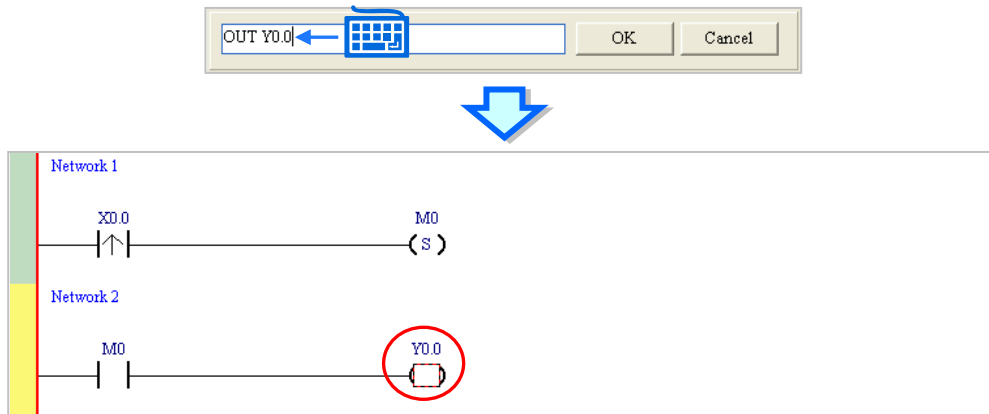

**Additional remark**

A contact and a coil can be created by typing simple instructions. Please refer to the description below. (The instructions typed are case-insensitive.)

- Inserting a normally-open contact (contact A): “A Device address”



- Inserting a normally-closed contact (contact B): “B Device address”

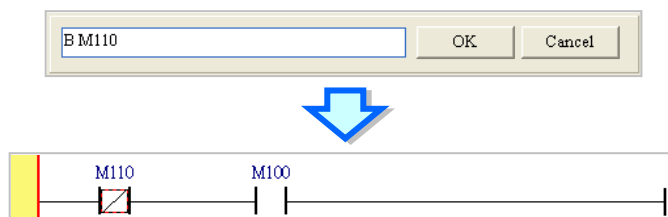

- Inserting an output coil (OUT): “O Device address”

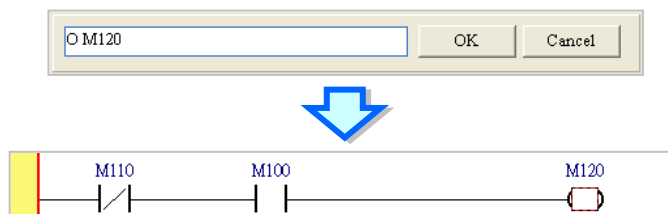

### 4.5.4 Basic Editing - Selection of a Network and Operation

Before an object in a network is selected, users have to press Esc on the keyboard, or click  on the toolbar. After the cursor appears as a small arrow, you can click the object in the network. The basic selection is shown below.

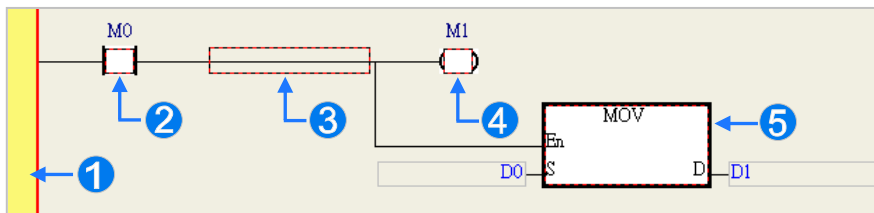

- ❶ Selecting the network
- ❷ Selecting the input contact
- ❸ Selecting the network
- ❹ Selecting the output coil
- ❺ Selecting the block

If you want to select a group of devices, you can click a device, and drag it to draw a frame round the group of devices. You can also select the group of devices by clicking the first device, pressing Ctrl+B on the keyboard, clicking the last device, and pressing Ctrl+B on the keyboard. You must draw a frame round devices which are in the same network, and the devices must be adjacent to one another. Besides, input devices and output devices can not be in the same frame.

4

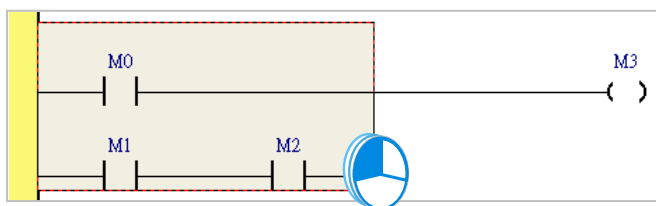

If you want to select several networks, you can press Ctrl on the keyboard, and click the networks. You can also select a range of networks by pressing Shift on the keyboard, clicking the first network within the range, and the last network within the range.

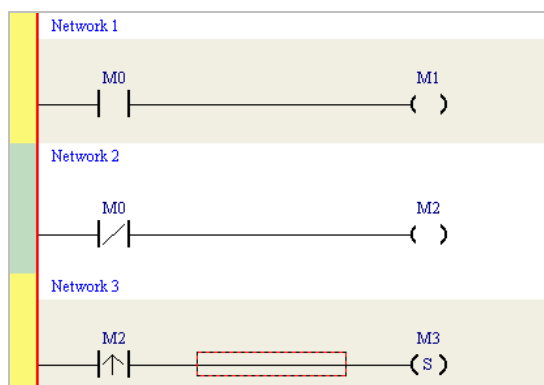

If you right-click an object after the object is clicked, you can click an item on the context menu.

Item	Function
<b>Undo</b>	Undoing the last action (The number of previous actions that can be undone is 20.)
<b>Redo</b>	Redoing an action which has been undone
<b>Cut</b>	Cutting a device, a block, or a network
<b>Copy</b>	Copying a device, a block, or a network
<b>Paste</b>	Paste an object which has been copied or cut on the present position
<b>Paste right</b>	Pasting an object at the right side of the position selected (The object will be connected to the position selected in series.)
<b>Paste under</b>	Pasting an object under the position selected (The object will be connected to the position selected in parallel.)
<b>Delete</b>	Deleting a device, a block, or a network
<b>Activate/Inactivate Network</b>	Activating or Inactivating the network selected (The network which is inactivated is ignored when the program is compiled.)

You can proceed with the operation in the example.

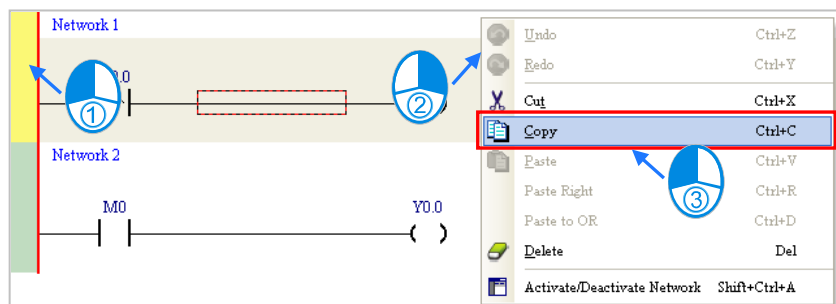

- (1) Select network 1, right-click network 1, and click **Copy** on the context menu.

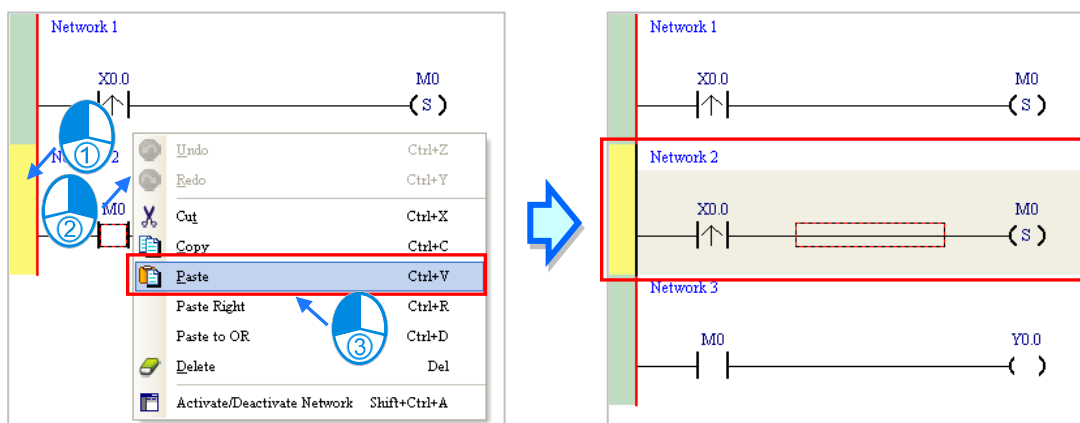

- (2) Select network 2, right-click network 2, and click **Paste** on the context menu. A copy of network 1 will be put above network 2, and network 2 will become network 3.



### 4.5.5 Basic Editing - Connecting a Contact in Parallel

(1) Click  on the toolbar, and then move the mouse cursor to the input contact in network 2. The mouse cursor will appear as a contact. Move the mouse cursor to the button of the input contact in network 2. After the mouse cursor appears as , you can click the left mouse button. A contact will be connected to the input contact in network 2 in parallel.

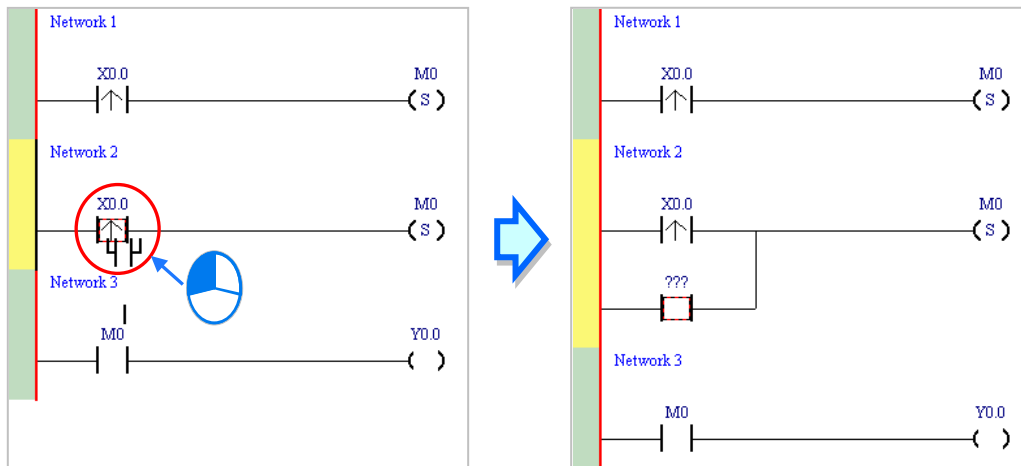

(2) Write the program in network 2 shown below in the way described above.

4

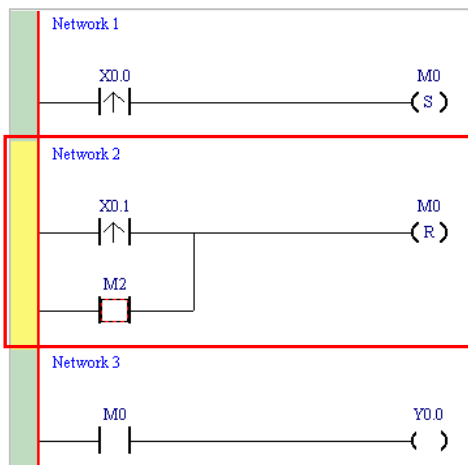

#### Additional remark

After you select a group of contacts, you can connect a contact to the group of contacts in the way described above.

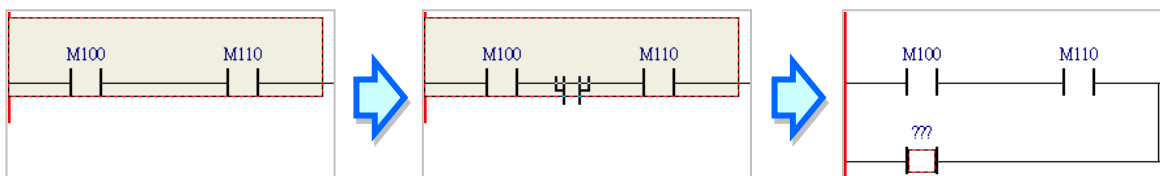

### 4.5.6 Basic Editing—Editing a Comment

- (1) Make sure that  on the toolbar is pressed. Click the position above a device name, type a comment in the box, and press Enter on the keyboard.

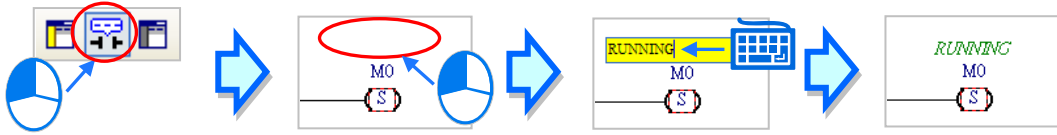

- (2) Make sure that  on the toolbar is pressed. Click the position under a network number, and then type a comment in the box. If you want to start a new line of text at a specific point, you can press Shift+Enter on the keyboard. Press Enter on the keyboard after the editing is complete.

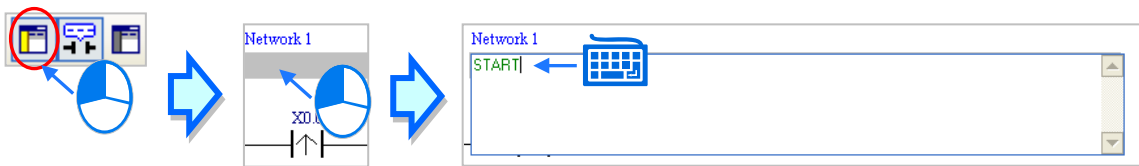

- (3) Write the program shown below in the way described above.

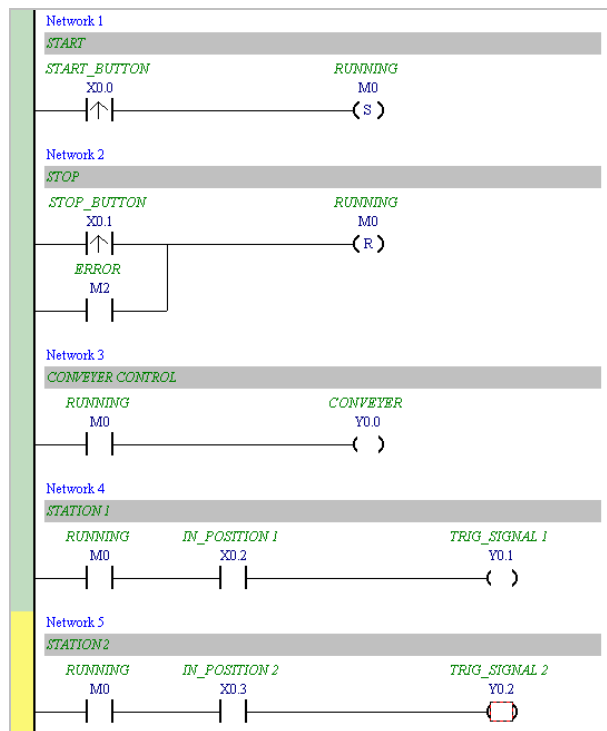



### 4.5.7 Basic Editing—Inserting an Applied Instruction

Put network 6 under network 5, and then write the program shown below. You can insert an applied instruction (standard instruction) in one of the three ways described below.

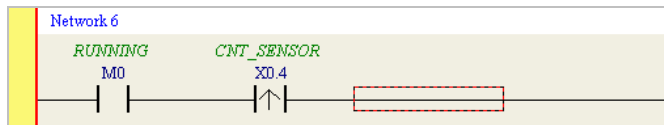

● Method 1

Click the position where an instruction will be inserted, type the instruction (INC in this example), and press Enter on the keyboard.

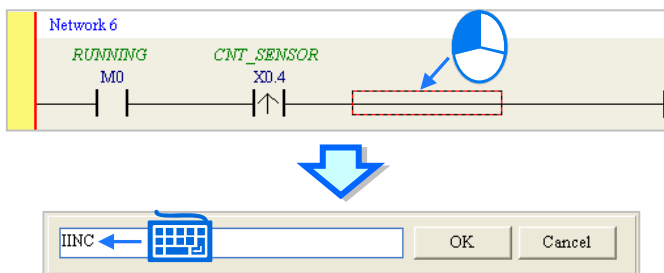

4

● Method 2

Unfold the **APIs**(Standard Instructions) section in the project management area, find the instruction type, and unfold the instruction type section.

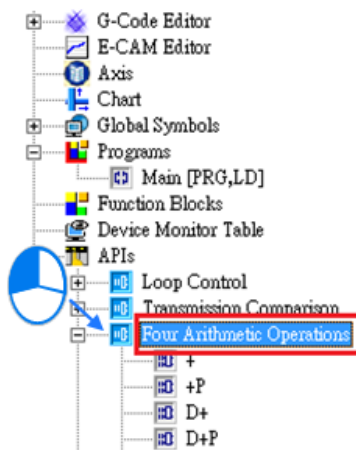

Select the instruction (INC in this example) which will be inserted, and then drag it to the position where it will be inserted.

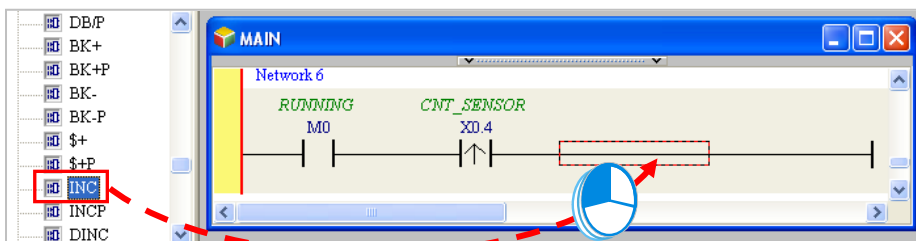

● Method 3

Click the position where an instruction will be inserted, click  on the toolbar, select the instruction (INC in this example) which will be inserted in the **API/FB** window, and click **Insert**.

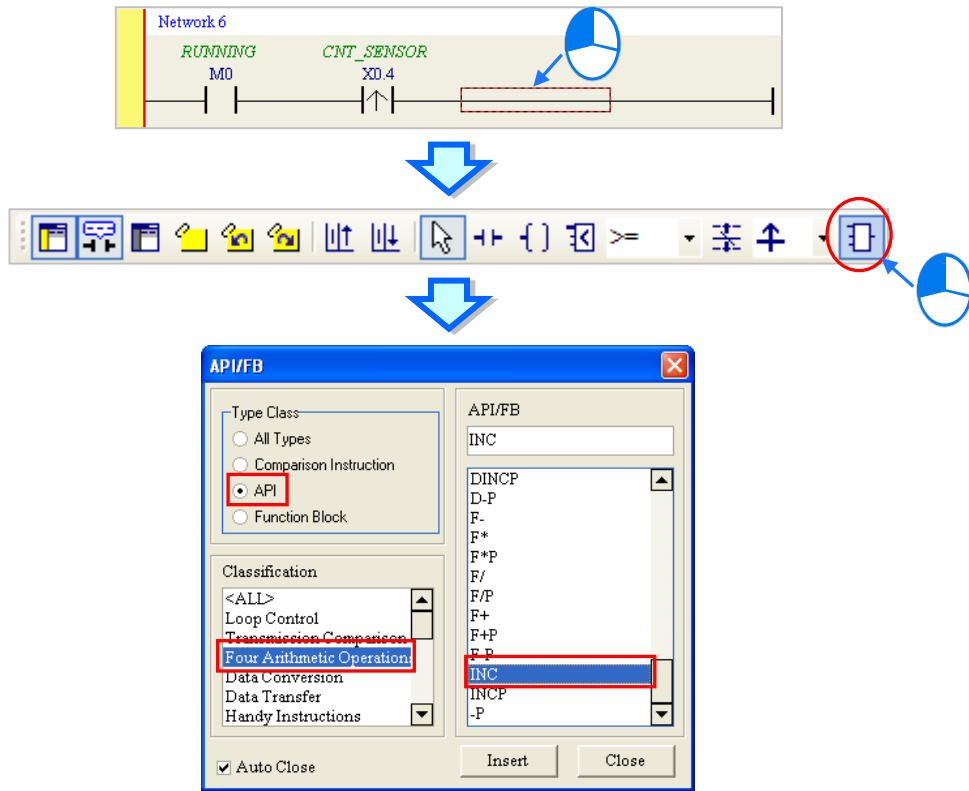

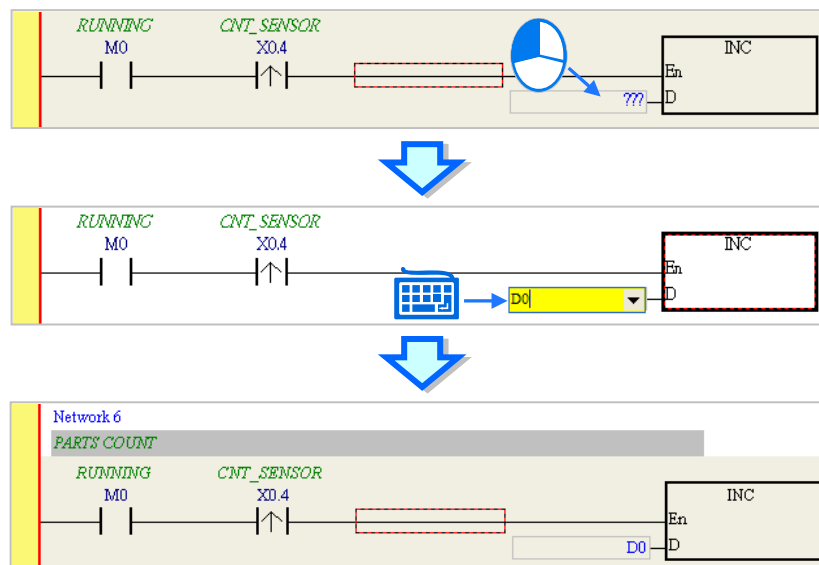

After the instruction is inserted successfully, you can assign a device address to the operand, and write the program shown below.

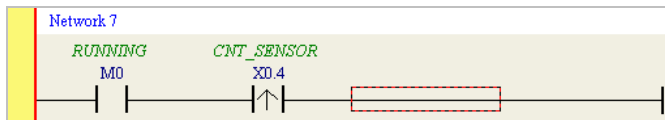

### 4.5.8 Basic Editing—Creating a Comparison Contact and Typing a Constant

A comparison contact can be inserted not only in one of the three ways described in section 4.5.7, but also by means of the following steps. You need to put network 7 under network 6, and write the program shown below.



(1) Click  on the toolbar, and then select a type (>= in this example).



(2) Click  on the toolbar, and then move the mouse cursor to the position where the comparison contact will be inserted. The mouse cursor appears as a comparison contact when the mouse is moved to the left side of the red frame, the right side of the red frame, or the bottom of the red frame. You can decide where to insert the comparison contact. After you decided on a position, you can click the left mouse button to insert the comparison contact.

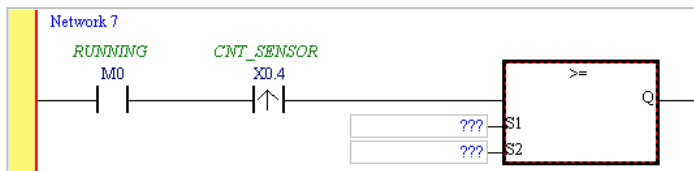
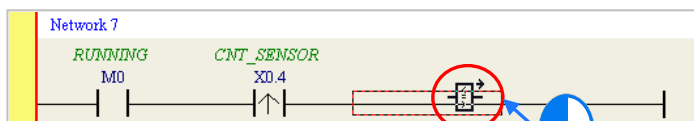

Write the program shown below in the way described above. If you want to type a decimal value in ISPSOft, you can type it directly. If you want to type a hexadecimal value in ISPSOft, you have to type "16#" and the hexadecimal value, e.g. 16#7FFF. In ISPSOft, an octal value is preceded by 8#, and a binary value is preceded by 2#.

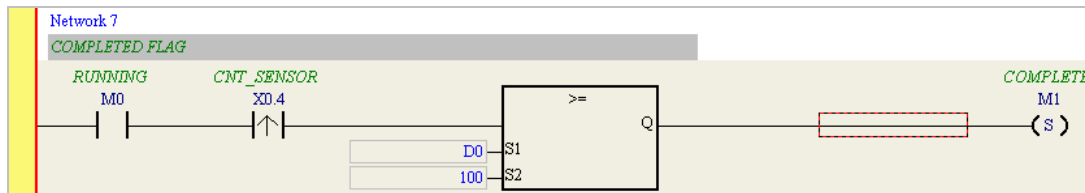

### 4.5.9 Writing a Program

The creation of a traditional ladder diagram in ISPSOft has been introduced. You can write the program shown below in the way described in the previous sections. Owing to the fact that the program has not been compiled, the mother line at the left side of the ladder diagram is red during the writing of the program. The following sections will introduce how to compile the program, and how to download the program which has been compiled to the CPU module to test the program.

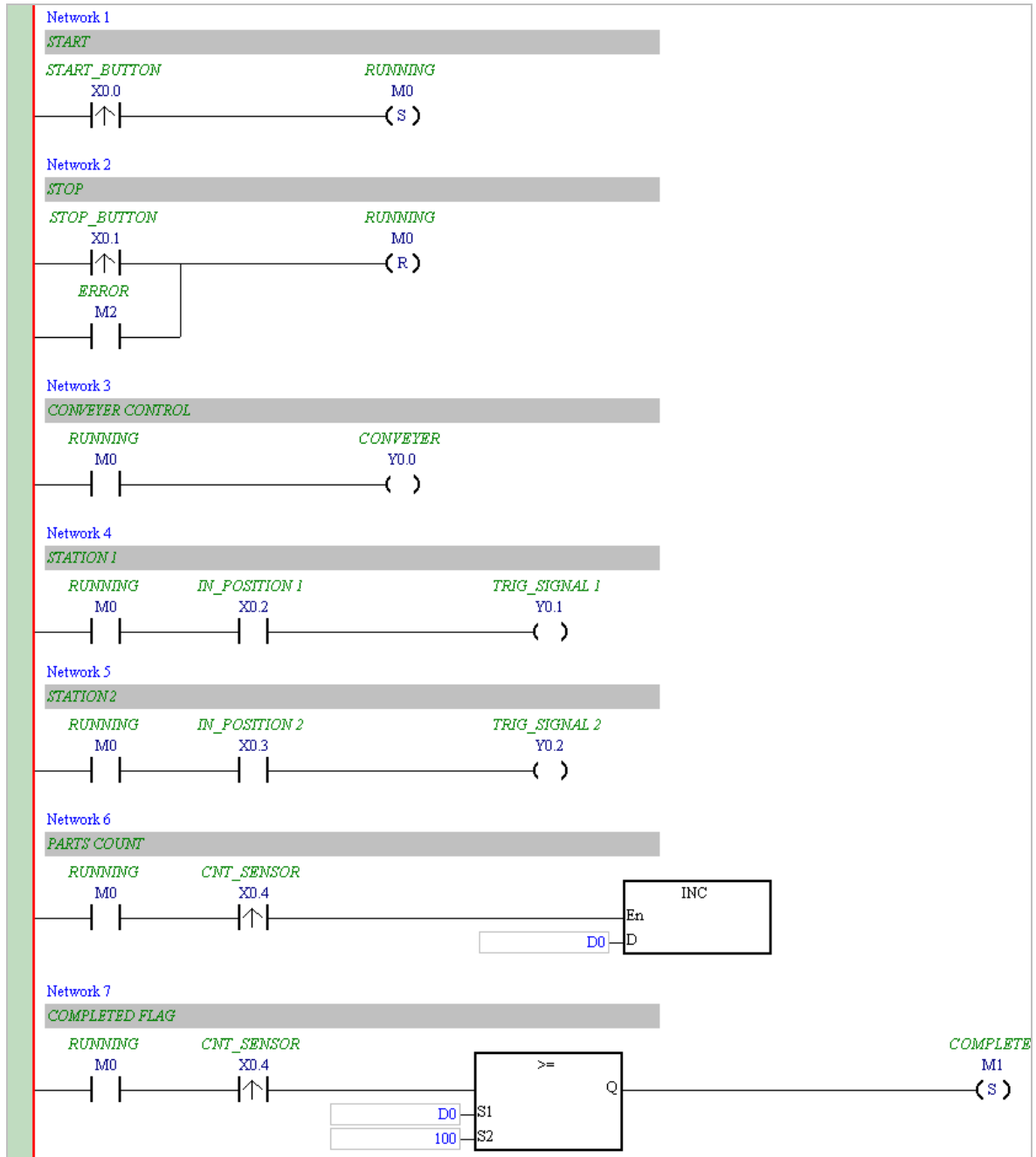

\*1. The program above is saved in the folder denoted by ...\\ISPSOft x.xx\\Project\\Example\\Gluing\_System\_C.

\*2. Please refer to chapter 8 of ISPSOft User Manual for more information about creating a ladder diagram.

### 4.5.10 Checking and Compiling a Program

After you write a program, you can check the syntax of the programming language or compile the program. The syntax and the structure in the present window will be checked after the **Check** function is enabled. The whole project will be checked after the **Compile** function is enabled. If there is no error in the project, an execution code will be generated automatically. After the program is compiled successfully, the mother line at the left side of the ladder diagram will become black.

● **Check**

Click **Check** on the **Compile** menu, or  on the toolbar.

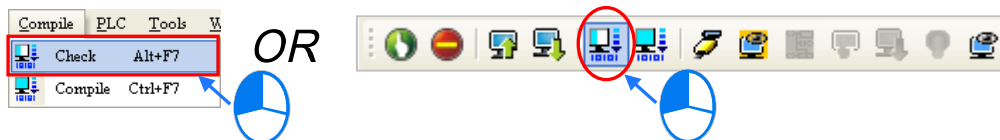

● **Compile**

Click **Compile** on the **Compile** menu, or  on the toolbar.

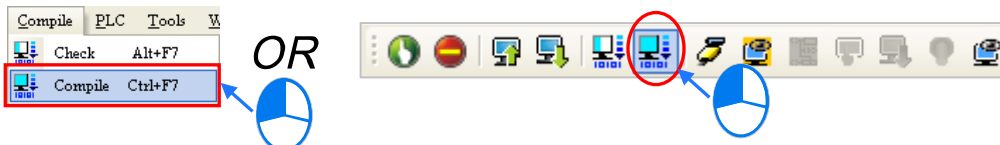

After the check is complete, the **Compile Message** page shows the result related to the check. If there is any error in the project, the **Compile Message** page will show the related message. After the message is clicked, the system will automatically lead users to the place where the error occurs. You can enable the **Check** function or the **Compile** function after the error is eliminated.

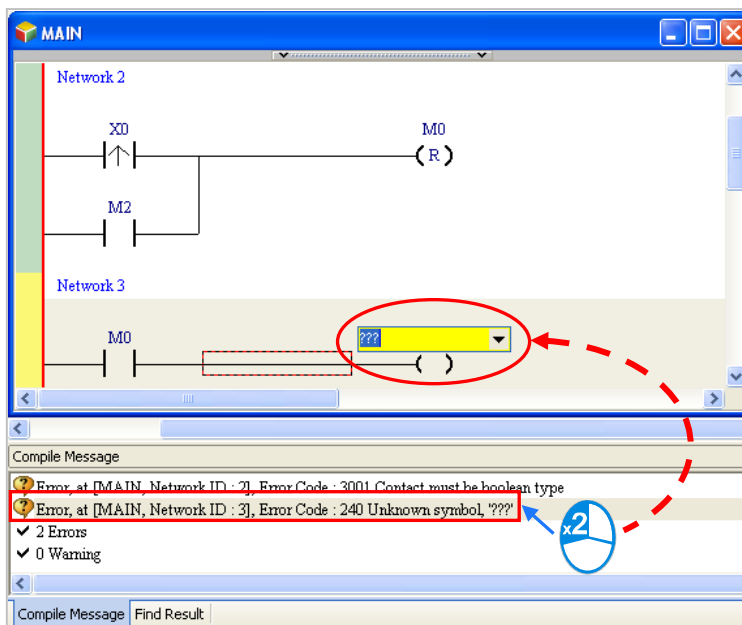

## 4.6 Testing and Debugging a Program

### 4.6.1 Creating a Connection

Before a program and parameters are downloaded to a PLC or monitored online, ISPSOft must be connected to the PLC. In this example, ISPSOft is connected to the CPU module AHxxEMC-5A through a USB cable. Please refer to section 3.2 for more information about connecting ISPSOft to a PLC in other ways. Please refer to operation manuals for more information about wiring.

**Those who have connected ISPSOft to a PLC successfully in accordance with the contents of section 3.2 can skip this section.**

- (1) Install the modules on the main backplane in accordance with the hardware configuration in HWCONFIG. Make sure that the wiring is correct, and then power the CPU module.
- (2) Make sure that COMMGR is started, and the icon representing COMMGR is displayed on the system tray. If the icon representing COMMGR is not displayed on the system tray, you can start COMMGR by clicking the shortcut on the **Start** menu (**Start>Programs>Delta Industrial Automation>Communication>COMMGR**).

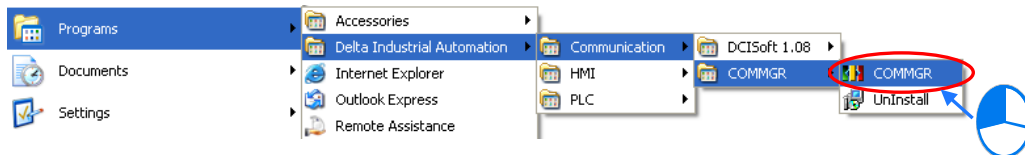

- (3) Double-click the icon representing COMMGR on the system tray to open the **COMMGR** window. Click **Add** in the **COMMGR** window to create a driver.

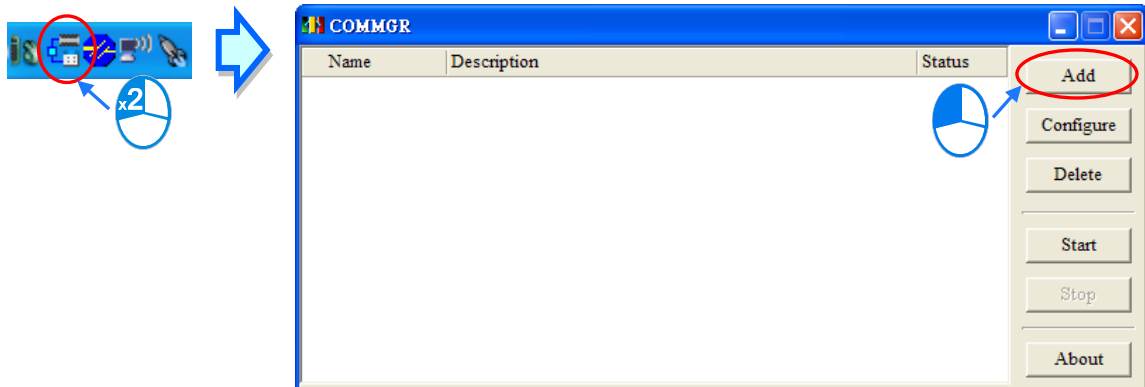

(4) Set the parameters in the **Driver Properties** window, and then click **OK**.

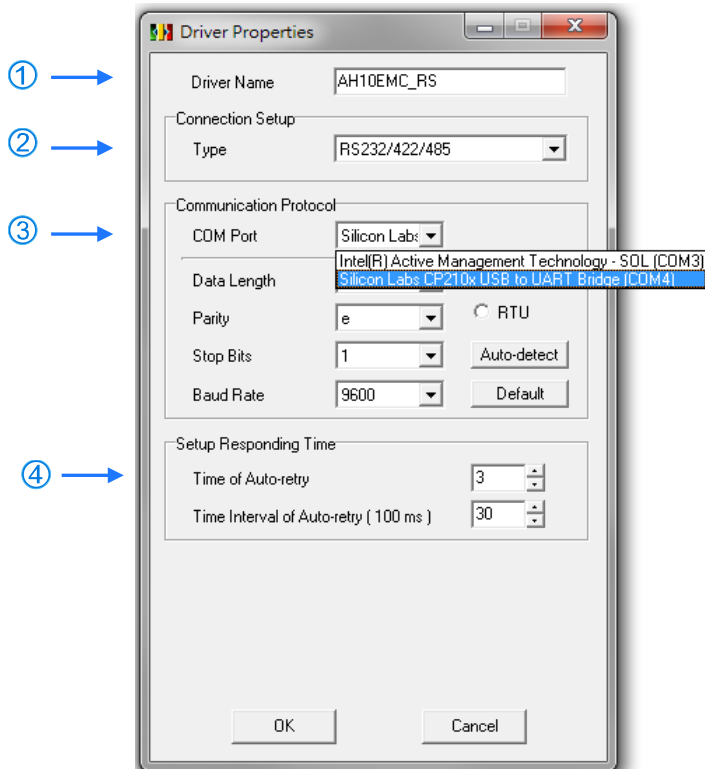

4

- ① Type a driver name in the **Driver Name** box.
- ② Select **RS232/422/485** in the **Type** drop-down list box in the **Connection Setup** section.
- ③ Select a communication port in the **COM Port** drop-down list box. If the first two steps are complete, the PLC which is connected and its communication port will be displayed in the **COM Port** drop-down list box.
- ④ You can select the number of times the sending of a command is retried if a connection error occurs in the **Time of Auto-retry** box, and select an interval of retrying the sending of a command in the **Time Interval of Auto-retry** box.

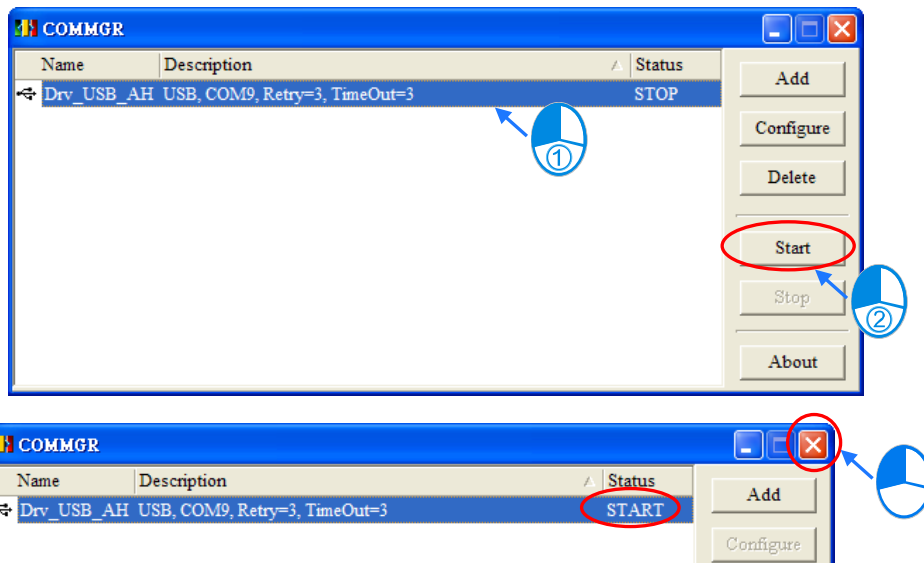

- (5) Start ISPSOft, and then click **Communication Settings...** on the **Tools** menu. In the **Communication Setting** window, select the driver which has been created in the **Driver** drop-down list box, appear, and select 0 in the **Station Address** drop-down list box, and click **OK**. The information about the driver will be displayed in the status bar in ISPSOft.

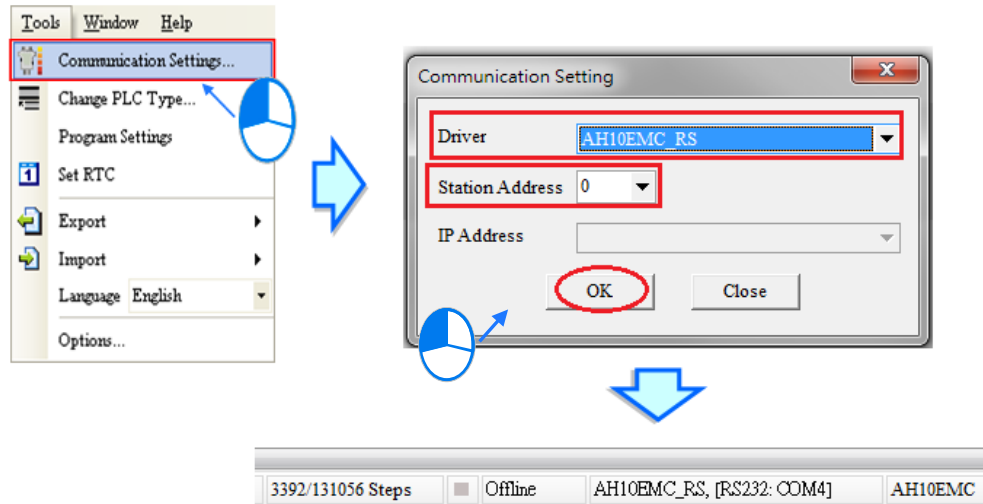

- (6) Click **System Information** on the **PLC** menu. ISPSOft will retrieve related information from the PLC. If the computer communicates with the CPU module normally, the related information retrieved from the PLC will be displayed in the **System Information** window.

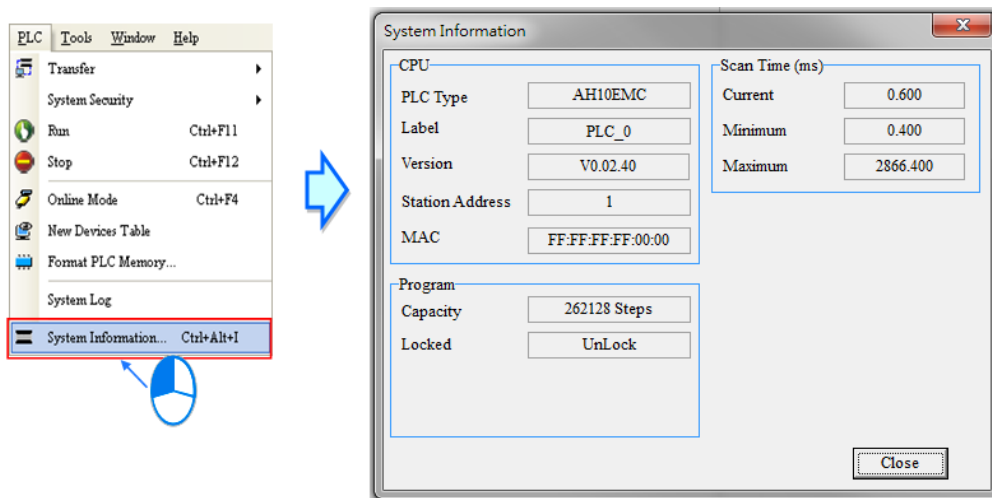



### 4.6.2 Downloading a Program and Parameters

If ISPSOft is connected to a PLC normally, the parameters and the program in the project can be downloaded to the PLC. First, start ISPSOft and open the project created in the previous sections. In this example, two types of parameters are downloaded to the CPU module. They are the hardware configuration and the program.

● **Downloading the hardware configuration**

- (1) Double-click **HWCONFIG** in the project management area to open the **HWCONFIG** window.

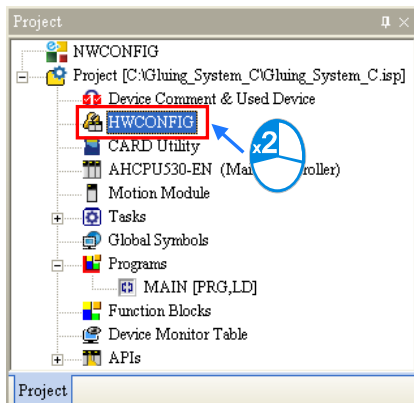

- (2) The hardware configuration is displayed in the window. Before the hardware configuration is downloaded to the CPU module, you have to make sure that the actual hardware configuration is the same as the hardware configuration in the window.

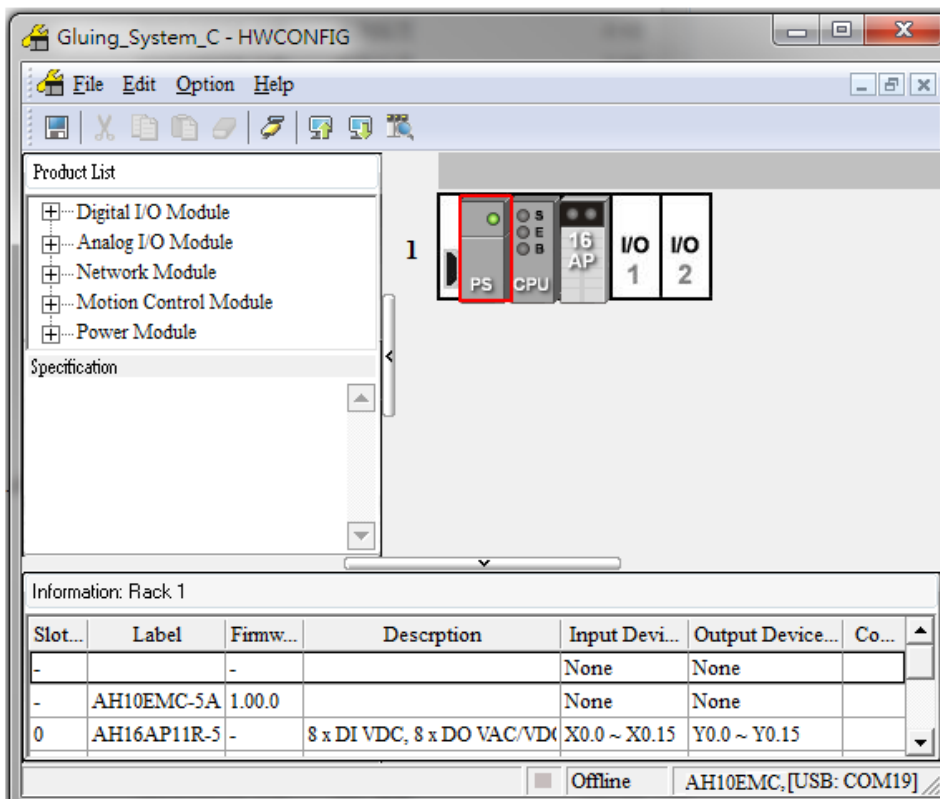

4

- (3) After you click **Download** on the **Option** menu, or  on the toolbar, the **Transfer Items** window will appear. Select the **Download All Items** checkbox, the hardware configuration and all types of parameters will be downloaded to the CPU module after **OK** is clicked. You can also deselect the **Download All Items** checkbox then select the **Hardware Configuration Settings** and **COM PORT**. The hardware configuration of the two types of parameters will be downloaded to the CPU module after **OK** is clicked.

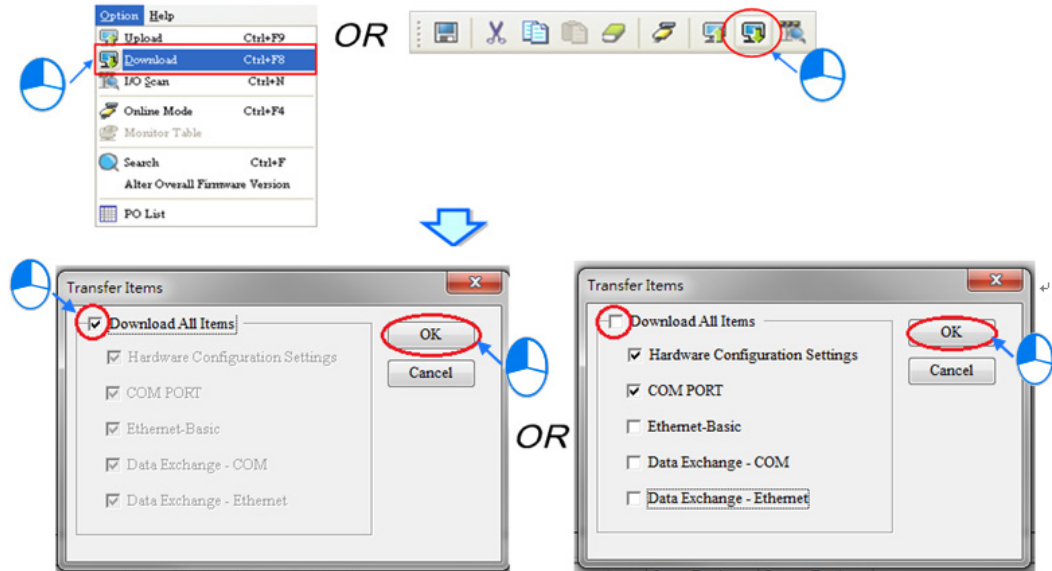

- (4) After the hardware configuration is downloaded to the CPU module successfully, the BUS FAULT LED indicator on the CPU module will be OFF. You can close the **HWCONFIG** window. If the BUS FAULT LED indicator on the CPU module is still ON or blinking, the CPU module is in an abnormal state. Please make sure that the actual hardware configuration is the same as the hardware configuration in the **HWCONFIG** window again, or refer to the operation manual for more information about eliminating the error. Please refer to chapter 4.4 for more information about HWCONFIG.

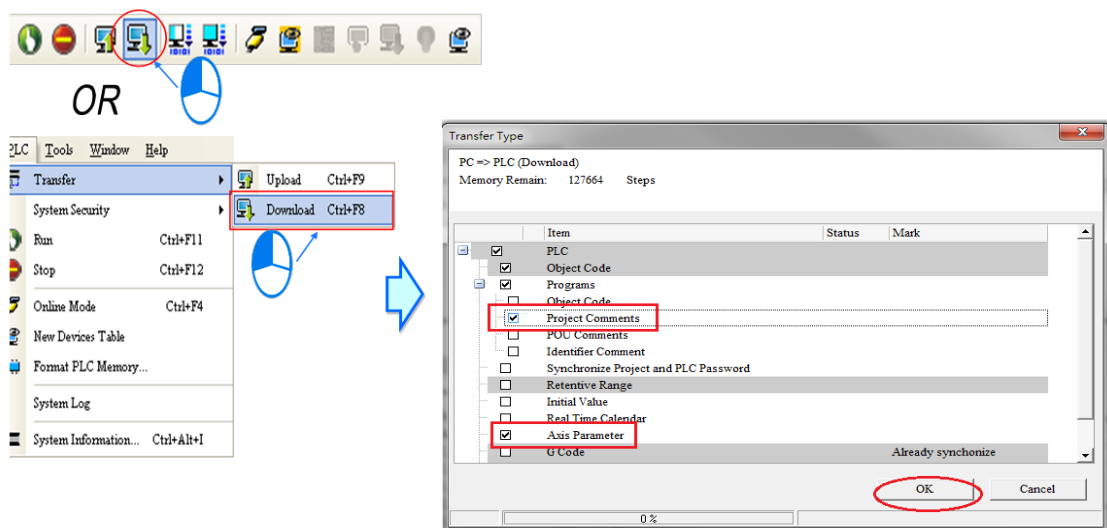

#### ● Downloading the program

After the program is compiled successfully, you can click the **PLC** menu, point to **Transfer**, and click **Download**. You can also click  on the toolbar after the program is compiled successfully. Select the **Program** checkbox and the **Project Comments** checkbox and the **Axis Parameter** checkbox in the **Transfer Setup** window so that the program in the CPU module can be uploaded later, and then click **OK**.



### 4.6.3 Connection Test

After a program is downloaded to a PLC, you can monitor the execution status of the PLC through ISPSOft. There are two monitoring modes that ISPSOft provide. One is the device monitoring mode, and the other is the program monitoring mode.

Monitoring mode	Description
 Device monitoring mode	You can monitor the statuses of the devices in the PLC through the monitoring table. In this mode, ISPSOft only needs to update the statuses of the devices. The present program in ISPSOft does not need to be the same as the program in the PLC.
 Program monitoring mode	In this mode, the operating status of the program is displayed in the program editing window. As a result, the present program in ISPSOft must be the same as the program in the PLC.

\*. The device monitoring function can be enabled independently. However, if the program monitoring function is enabled, the device monitoring function is also enabled.

After you click **Online Mode** on the **PLC** menu, or  on the toolbar, the online monitoring function will be enabled. The system will also enable the device monitoring mode and the program monitoring mode.

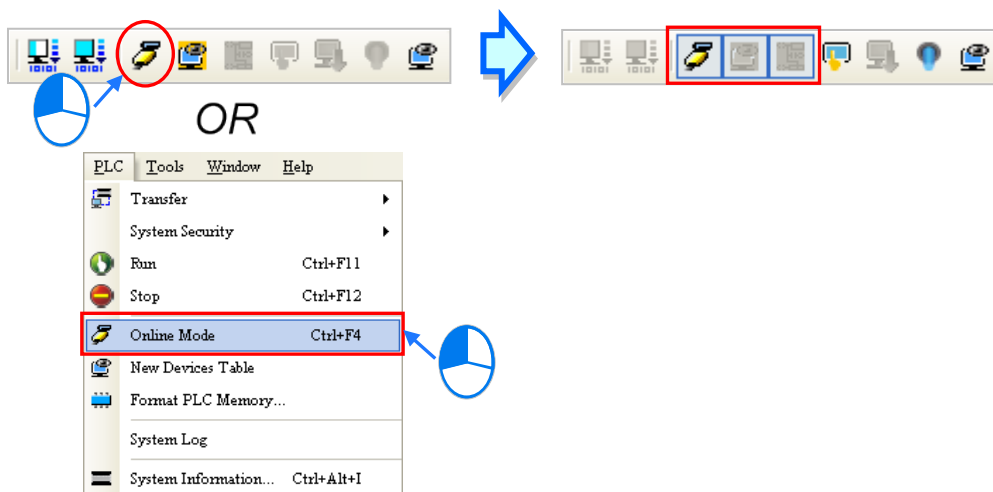



In the online monitoring mode, you can view the present scan time, the communication status, and the status of the PLC in the status bar in ISPSOft.

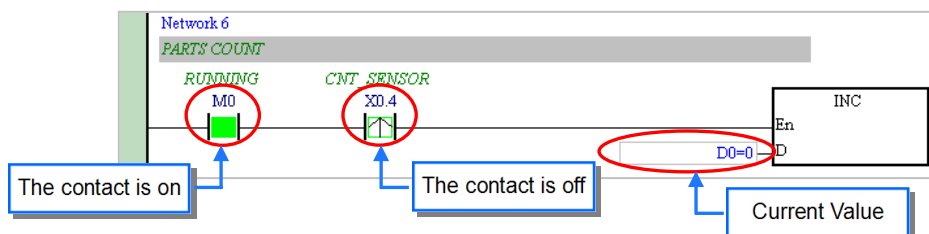

Besides, the present statuses of the devices will be displayed in the original program editing window after the program monitoring function is enabled.



You can change the operating status of a PLC by the RUN/STOP switch on the PLC. You can also change the operating status of the PLC through the functions provided by ISPSOft. After you click **Run** on the **PLC** menu or  on the toolbar, the PLC will begin to run. The PLC will stop running after **Stop** on the **PLC** menu or  on the toolbar is clicked.

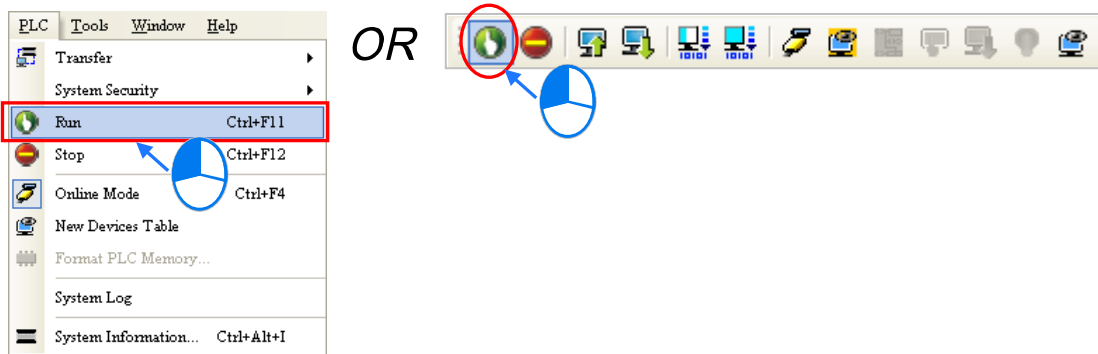

In the online monitoring mode, you can select a device, right-click the device, and click an item on the context menu. During a test, you can change the status of a device or the value in a device by clicking an item on the context menu.

**⚠ Before the status of a device is changed, you have to make sure that the operation does not cause damage to the system or staff.**

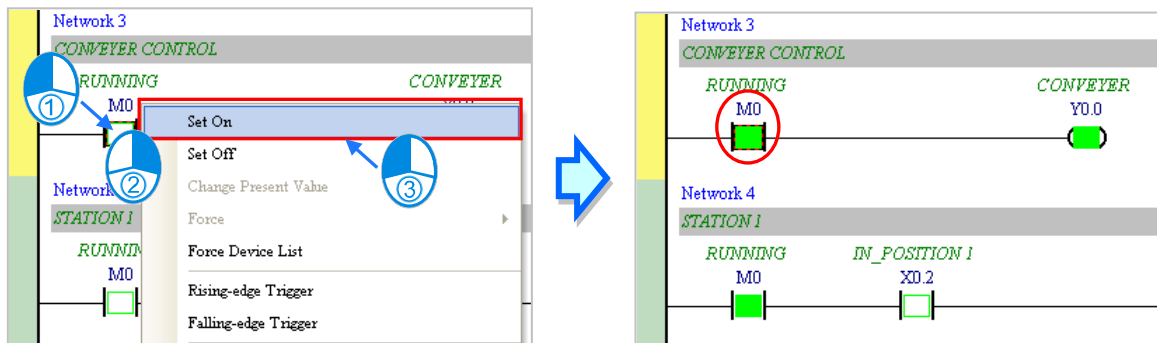

The items on the context menu are described below. **Force** on the context menu only applies to input contacts and output contacts.

Item	Description
Set On	Setting the contact selected to ON
Set Off	Setting the contact selected to OFF
Rising-edge Trigger	No matter what the state of the contact selected is, the system set the contact to OFF, and then set it to ON.
Falling-edge Trigger	No matter what the state of the contact selected is, the system set the contact to ON, and then set it to OFF.
Force	Forcing an input contact or output contact ON or OFF
Force Device List	Forcing several input contacts or output contacts in the tables ON or OFF

If you want to change the value in a device, you can click the device, right-click the device, click **Change Present Value** on the context menu, and set a present value in the **Enter Present Value** window.

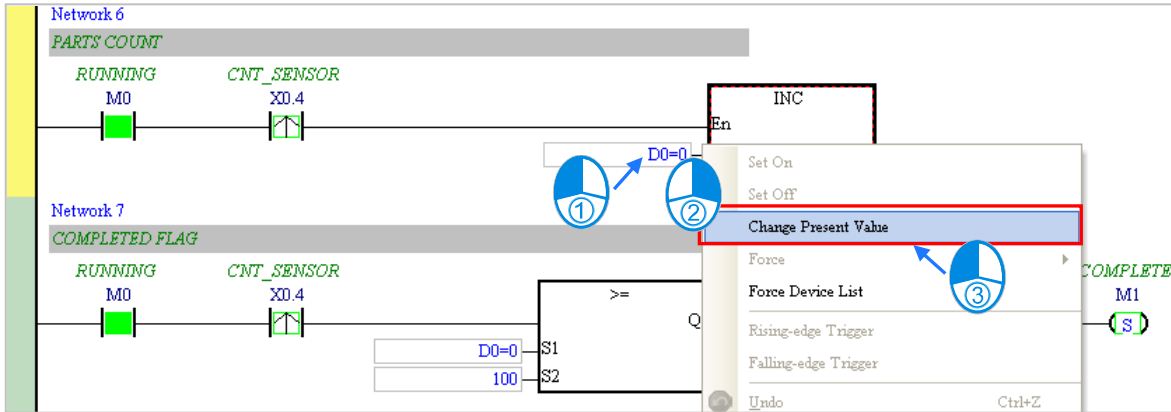

The **Enter Present Value** window is described below.

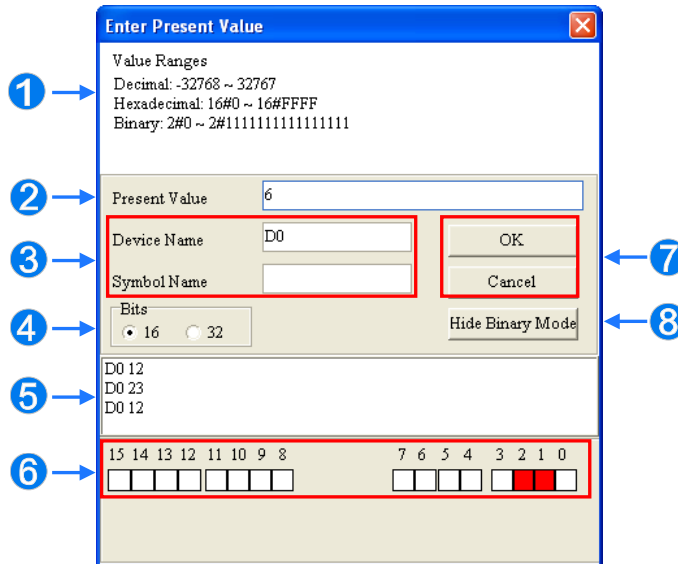

- ① Message
- ② You can type a value in the **Present Value** box.
- ③ Name of a device or a symbol whose present value will be changed
- ④ You can type a 16-bit value or a 32-bit value.
- ⑤ Value change history (Format: Device name Value)
- ⑥ In the binary mode, you can set the states of the bits through the mouse.
- ⑦ The setting values will be applied after **OK** is clicked. The window will be closed after **Cancel** is clicked.
- ⑧ You can display or hide the binary mode.

In this example, X0.0~X0.15 and Y0.0~Y0.15 are input devices and output devices assigned to the digital I/O module AH16AP11R-5A. After the parameters in the hardware are downloaded to the CPU module, the states of X0.0~X0.15 will be the same as the states of the inputs on the actual module. Even if you set X0.0~X0.15 to ON or OFF in the program editing window, the states of X0.0~X0.15 will be updated by the actual input signals.

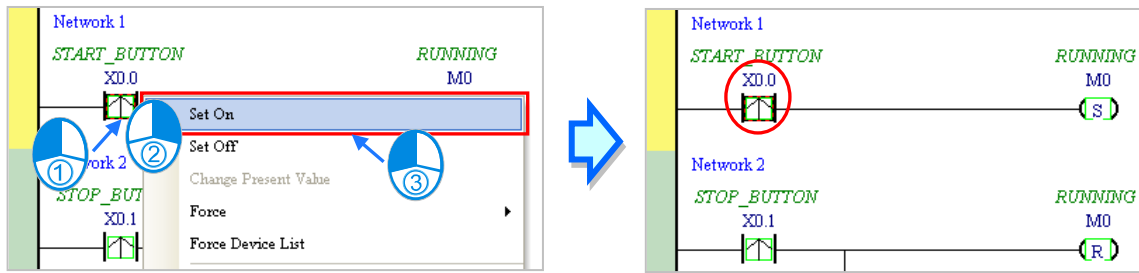

However, an input contact can be forced ON or OFF during a test. You can click an input contact or output contact which will be set, right-click the contact, point to **Force** on the context menu, and select **On (X/Y)**, **Off (X/Y)**, **Release (X/Y)**, or **Release All**. If an input contact or output contact is forced ON or OFF, a lock symbol will appear at the left side of the contact.

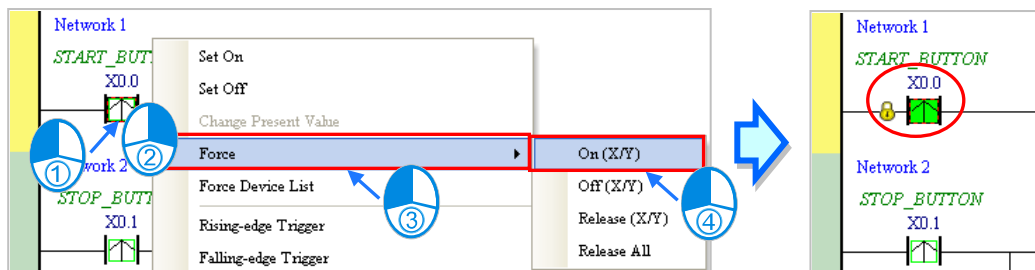

Force	Description
On (X/Y)	Forcing the input contact or output contact selected ON
Off (X/Y)	Forcing the input contact or output contact selected OFF
Release (X/Y)	Releasing the contact from the locked state
Release All	Releasing all the contacts from the locked states

If an output contact in the program is forced ON or OFF, the output state of this contact will not be affected by the program execution result.



\*. If the online monitoring function is disabled, the contacts will not be automatically released from the locked states. As a result, you have to check whether the contacts need to be released from the locked states after the test is complete.

There are two ways to create a monitoring table. You can create a monitoring table online or offline.

● **Method 1**

Click **New Devices Table** on the **PLC** menu, or  on the toolbar.

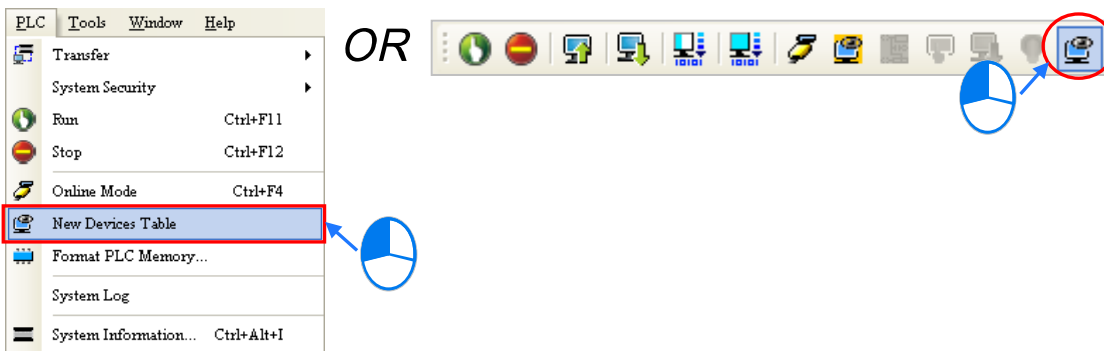

● Method 2

Right-click **Device Monitoring Table** in the project management area, point to **Device Monitor** on the context menu, and click **Add**.

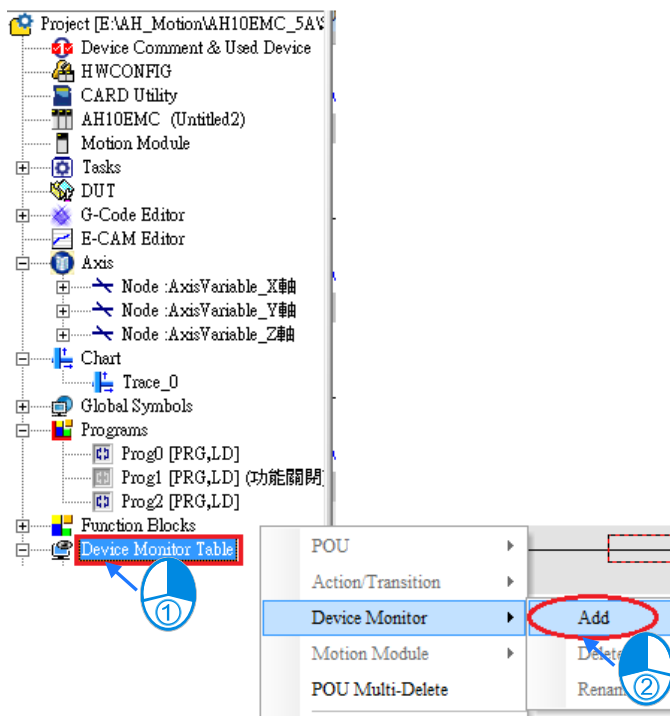

Type a table name in the **Add Monitor Table** window, and then click **OK**. An item will be under **Device Monitor Table** in the project management area. If you want to open the monitoring table, you can double-click the item. Besides, you can create several monitoring tables in the project, and the monitoring tables created will be saved with the project.

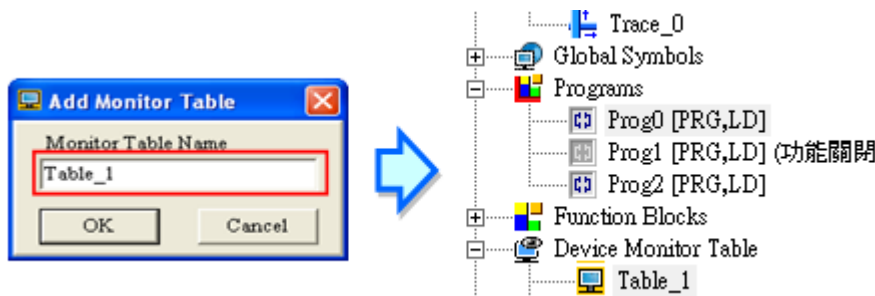

After the item is double-clicked, a window will appear. You can add items which will be monitored to the window. If you want to add an item to the window, you have to double-click the blank in the monitoring table, or type a device name directly, and type a start address and the number of devices which will be monitored in the **Device Monitor Input** window. Please notice that 100 items at most can be added to a monitoring table.

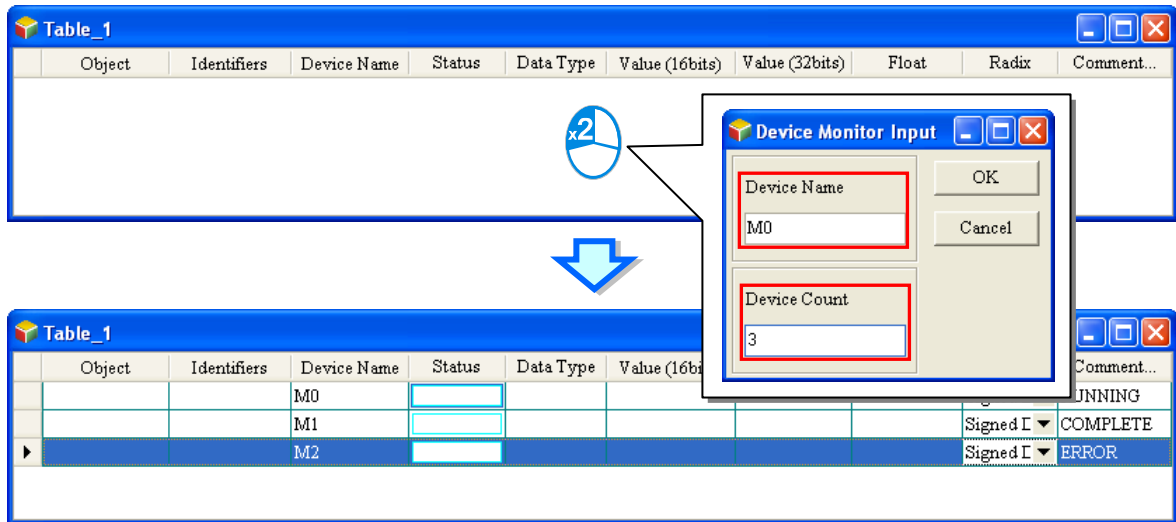

You can press Insert on the keyboard to switch between inserting an item in the monitoring table and replacing an item in the monitoring table. The mode which is selected is displayed in the status bar in ISPSOft.

4

If the insertion mode is selected, the item added will be above the item selected in the monitoring table. If the replacement mode is selected, the item added will overwrite the item selected in the monitoring table.

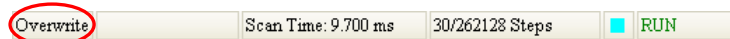

If you want to hide certain columns in the monitoring table, you can right-click the monitoring table, point to **Set the Fields**, and unselect certain items. After an item is unselected, the corresponding column will disappear.

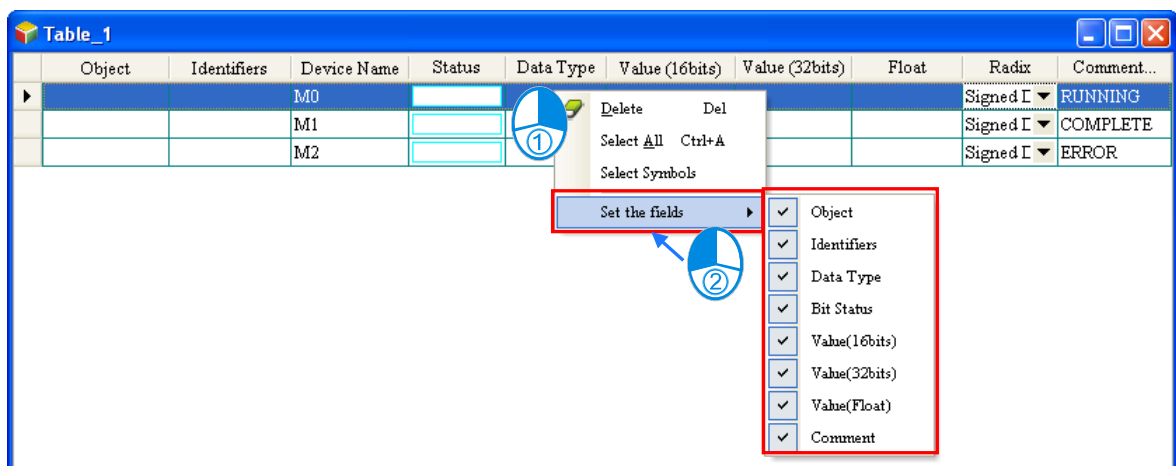



The description of the columns in the monitoring table is as follows.

Column	Description
Source	The source of a symbol
Identifier	The identifier of a symbol
Device name	The name of a device monitored
Status	If a bit device or a contact is monitored, the state will be ON or OFF.
Data type	If a symbol is monitored, the data type of the symbol will be displayed.
Value (16 bits)	In the online mode, a 16-bit value is displayed.
Value (32 bits)	In the online mode, a 32-bit value is displayed.
Float	In the online mode, a 32-bit floating-point number is displayed.
Radix	You can select a format in which a value is represented.
Comment	The comments on a device or the comment on a symbol is displayed.

After the monitoring table is created, you can monitor the items in the monitoring table in the online mode. Besides, after you right-click an item in the monitoring table in the online mode, a context menu which is the same as the context menu which will appear after a device in the program editing window is clicked will appear. You can change the state of the item or the value in the item by clicking an item on this context menu.

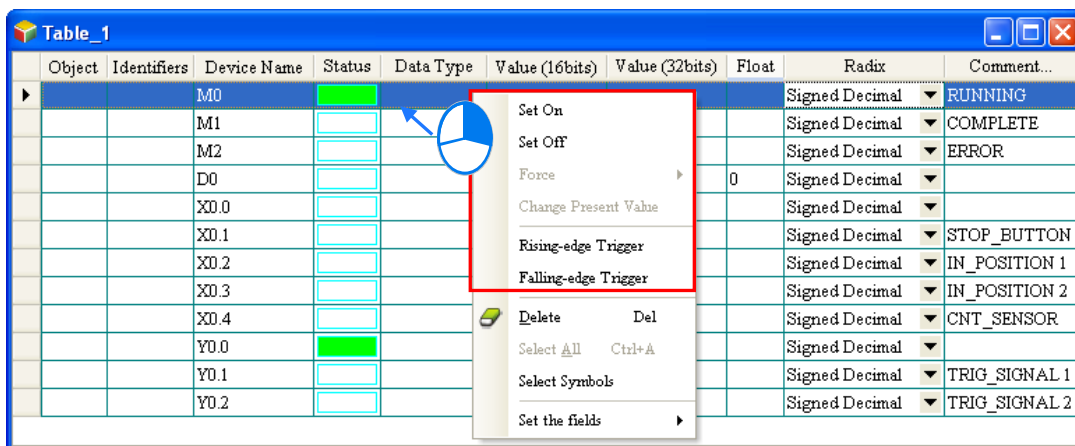

The program created in this chapter can be tested and debugged through the monitoring table created in this section. Please refer to chapter 14 of ISPSOft User Manual for more information about testing and debugging a program.

#### 4.6.4 Setting a Real-time Clock

The real-time clock in a PLC can be set by a tool provided by ISPSOft. Before the real-time clock in a PLC is set, you have to make sure that ISPSOft is connected to the PLC normally. Please refer to section 3.2 for more information about communication setting.

- After you click **Set RTC** on the **Tools** menu, the **SET RTC** window will appear. The date displayed at the top of the window is the date retrieved from the PLC when the window is opened, and the time displayed at the top of the window is the time retrieved from the PLC when the window is opened.

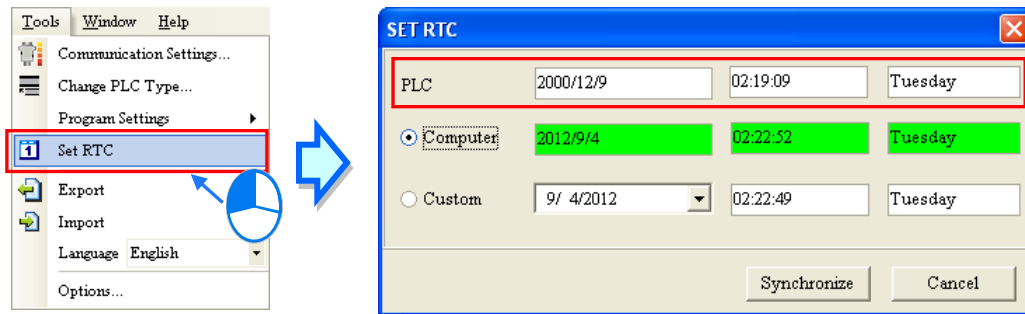

- (2) If the time on the computer's clock is the time on the real-time clock, you can select the **Computer** option button, and click **OK**.

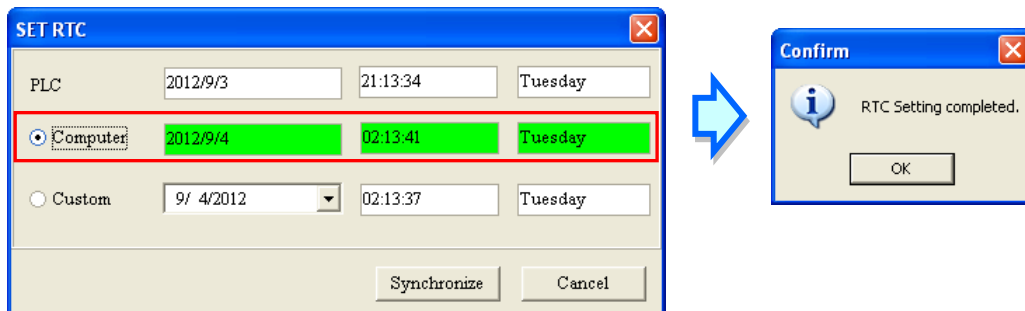

- (3) If you want to set the real-time clock by yourselves, you can select the **Custom** option button, and type a date and a time in the boxes. If you click  in the box, an auxiliary tool will appear. Click **OK** after the setting of the real-time clock is complete

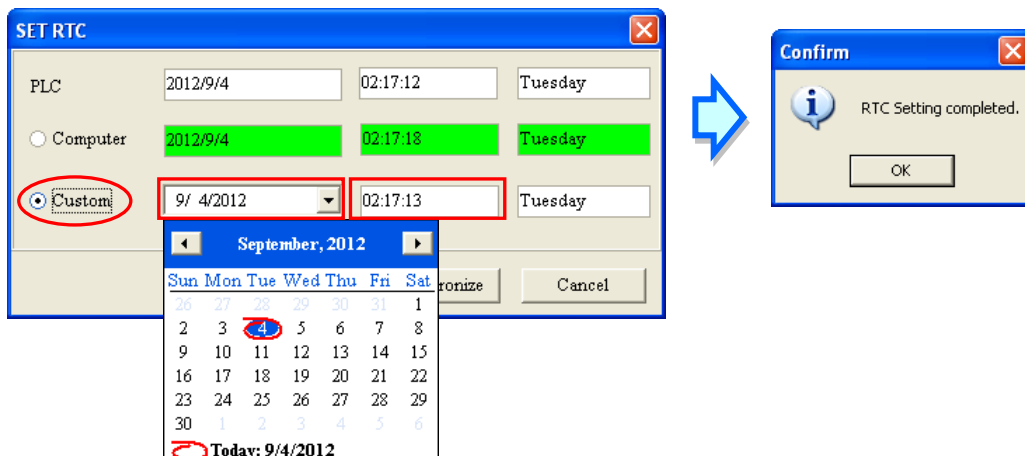

**MEMO**

---

# Chapter 5 Understanding Common Devices

## Table of Contents

- 5.1. Introduction .....5-2**
- 5.2. Common Devices .....5-2**
  - 5.2.1. Functions of Common Devices ..... 5-2
  - 5.2.2. Device List ..... 5-2
  - 5.2.3. Latched Devices..... 5-4
  - 5.2.4. Input Relays (X) ..... 5-5
  - 5.2.5. Output Relays (Y) ..... 5-5
  - 5.2.6. Auxiliary Relays (M) ..... 5-6
  - 5.2.7. Special Auxiliary Relays (SM/AM) ..... 5-6
  - 5.2.8. Data Registers (D) ..... 5-6
  - 5.2.9. Special Data Registers (SR/AR) ..... 5-7
  - 5.2.10. Link Registers (L)..... 5-7
  - 5.2.11. Stepping Relays (S) ..... 5-7
  - 5.2.12. Timers (T) ..... 5-7
  - 5.2.13. Counters (C) ..... 5-9
  - 5.2.14. 32-bit Counters (HC/AC)..... 5-10
  - 5.2.15. Index Registers (E) ..... 5-10
  - 5.2.16. Values and Constants (K, 16#)..... 5-11
  - 5.2.17. Floating-point Numbers (F, DF) ..... 5-12
  - 5.2.18. Strings (“\$”) ..... 5-14
- 5.3. EtherCAT Symbols .....5-16**
- 5.4. Symbols.....5-16**
  - 5.4.1 Application of Symbols ..... 5-16
  - 5.4.2 Classes..... 5-16
  - 5.4.3 Data Types ..... 5-17
  - 5.4.4 Using Devices, Symbols and Instructions ..... 5-18
  - 5.4.5 Modifying a Symbol with an Index Register ..... 5-19
- 5.5. User-defined Data Type (ENUM) .....5-20**

## 5.1. Introduction

The chapter introduces the concept of common devices which will be used throughout the programming process. In addition to the common devices, to complete a more complicated program you may also need to use other elements such as symbols, enumerations which are also introduced in this chapter. For motion control programming, there are also specific motion control devices which can be used for setting motion axis parameters. As long as you equipped yourself with the knowledge of devices and symbols, you are ready to use instructions for programming.

For detailed information of instructions, refer to *AH Motion Controller - Standard Instructions Manual* and *AH Motion Controller - Motion Control Instructions Manual*.

## 5.2. Common Devices

This section describes the concept of values/strings and devices which include input/output/auxiliary relays, timers, counters, and data registers.

### 5.2.1. Functions of Common Devices

The procedure for processing the program in the PLC:

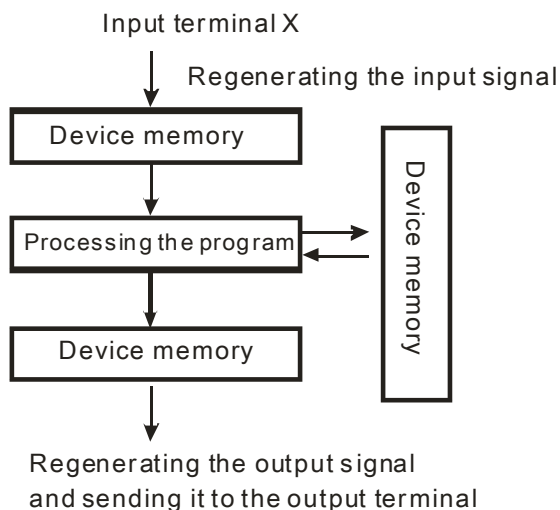

- Regenerating the input signal:
  1. Before the program is executed, the state of the external input signal is read into the memory of the input signal.
  2. When program is executed, the state in the memory of the input signal does not change even if the input signal changes from ON to OFF or from OFF to ON. Not until the next scan begins will the input signal be refreshed.
- Processing the program:
 

After the input signal is refreshed, the instructions in the program are executed in order from the start address of the program, and the results are stored in the device memories.
- Regenerating the state of the output:
 

After the instruction END is executed, the state in the device memory is sent to the specified output terminal.

### 5.2.2. Device List

Type	Device name		Number of devices	Range
Bit device	Input relay	X	8192	X0.0~X511.15 (Supporting Force ON/OFF)
	Output relay	Y	8192	Y0.0~Y511.15 (Supporting Force ON/OFF)
	Data register	D	1048576	D0.0~D65535.15
	Link registers	L	1048576	L0.0~ L65535.15
	Auxiliary relay	M	8192	M0~M8191
	Special auxiliary	SM		

Type	Device name		Number of devices	Range
	relay			
	Stepping relay	S	2048	S0~S2047
	Timer	T	2048	T0~T2047
	Counter	C	2048	C0~C2047
	32-bit counter	HC/AC	HC: 64 AC: 56 (AHxxEMC)	HC0~HC63 AC0~AC55 (AHxxEMC)
<b>Word device</b>	Input relay	X	512	X0~X511
	Output relay	Y	512	Y0~Y511
	Data register	D	65536	D0~D65535
	Special data register	SR	SR: 2048	SR0~SR2047
	Link registers	L	1048576	L0~ L65535
	Timer	T	2048	T0~T2047
	Counter	C	2048	C0~C2047
	32-bit counter	HC/AC	HC: 64 AC: 56 (AHxxEMC)	HC0~HC63 AC0~AC55 (AHxxEMC)
	Index register	E	32	E0~E31
<b>Constant*</b>	Decimal system	K	16 bits: -32768~32767 32 bits: -2147483648~2147483647	
	Hexadecimal system	16#	16 bits: 16#0~16#FFFF 32 bits: 16#0~16#FFFFFFFF	
	Single-precision floating-point number	F	32 bits: $\pm 1.17549435^{-38} \sim \pm 3.40282347^{+38}$	
	Double-precision floating-point number	DF	64 bits: $\pm 2.2250738585072014^{-308} \sim \pm 1.7976931348623157^{+308}$	
<b>String*</b>	String	"\$"	1~31 characters	
<b>Pointer*</b>	Pointer	PR		

\*1: The decimal forms are notated by K in the device table in **AH Motion Controller - Standard Instructions Manual**, whereas they are entered directly in ISPSOft. For example, entering 50 in ISPSOft indicates the value K50.

\*2: The floating-point numbers are notated by F/DF in the device table in **AH Motion Controller - Standard Instructions Manual**, whereas they are represented by decimal points in ISPSOft. For example, entering 500.0 in ISPSOft indicates the value F500.

\*3: The strings are notated by \$ in **AH Motion Controller - Standard Instructions Manual**, whereas they are represented by adding quotes ( " ") to the value in ISPSOft. For example, entering "1234" in ISPSOft indicates the string 1234.

### 5.2.3. Latched Devices

- Latched areas of each type of device

Device	Function	Device range	Latched area
X	Input relay	X devices (bit): X0.0~X511.15 X devices (word): X0~X511	All devices are non-latched.
Y	Output relay	Y devices (bit): Y0.0~Y511.15 Y devices (word): Y0~Y511	All devices are non-latched.
M*	Auxiliary relay	M0~M8191	Default: M0~M8191
SM	Special auxiliary relay	SM: SM0~SM2047	Some devices are latched, and can not be changed. Refer to the table of special auxiliary relays in the appendices for more information.
S	Stepping relay	S0~S2047	All devices are non-latched.
T*	Timer	T0~T2047	Default: T0~T2047.
C*	Counter	C0~C2047	Default: C0~C2047.
HC/AC*	32-bit counter	HC: HC0~HC63 AC: AC0~ AC55 (AHxxEMC)	Default: HC0~HC63. AC devices are non-latched.
D*	Data register	D device (bit): D0.0~D65535.15 D device (word): D0~D65535	Default: D0~D32767. At most 32768 devices can be latched devices.
SR	Special data register	SR: SR0~SR2047	Some are latched, and can not be changed. Refer to the list of special data registers for more information.
L	Link register	L0~ L65535	All devices are non-latched.
E	Index register	E0~E31	All devices are non-latched.

**\*Note:** You can define the range of latched areas for T, C, M and D and set the devices to be non-latched. Note that the range should not exceed the available device range, and only 32768 D devices at most can be non-latched. For example, you can set D50~D32817 or D32768~D65535 to latched area though the default range of latched areas is D0~D32767. Do not disconnect power or CPU module while the power is on. Once the PLC is disconnected from the backplane, the data in the latched area such as devices will be affected.

- Behavior of non-latched and latched devices

PLC action		Device type	Non-latched	Latched	Output relay
Power: OFF→ON			Cleared	Retained	Cleared
STOP ↓ RUN	The output relay is cleared.		Retained	Retained	Cleared
	The state of the output relay is retained.		Retained	Retained	Retained
	The state of the output relay returns to that before the PLC's stopping.		Retained	Retained	The state of the output relay returns to that before the PLC's stopping.
	The non-latched devices are cleared.		Cleared	Retained	Cleared
	The state of latched devices is retained.		Retained	Retained	Retained
RUN→STOP			Retained	Retained	Retained
SM204 is ON. (All non-latched devices are cleared.)			Cleared	Retained	Cleared
SM205 is ON. (All latched devices are cleared.)			Retained	Cleared	Retained
Default value			0	0	0

### 5.2.4. Input Relays (X)

- The function of the input

The input is connected to the input device (e.g. external devices such as button switches, rotary switches, number switches, and etc.), and the input signal is read into the PLC. Besides, contact A or contact B of the input can be used several times in the program, and the ON/OFF state of the input varies with the ON/OFF state of the input device.

- The input number (the decimal number)

For the PLC, the input numbers start from X0.0. The number of inputs varies with the number of inputs on the digital input/output modules, and the inputs are numbered according to the order in which the digital input/output modules are connected to the CPU module. The maximum number of inputs on the PLC can reach up to 8192, and the range is between X0.0 and X511.15.

- The input type

The inputs are classified into two types.

1. Regenerated input: Before the program is executed, the data is fed into the PLC according to the states of the inputs which are regenerated. For example, LD X0.0.
2. Direct input: During the execution of the instructions, the data is fed into the PLC according to the states of the inputs. For example, LD DX0.0.

### 5.2.5. Output Relays (Y)

- The function of the output

The task of the output is sending the ON/OFF signal to drive the load connected to the output. The load can be an external signal lamp, a digital display, or an electromagnetic valve. There are three types of outputs. They are relays,



transistors, and TRIACs (AC thyristors). Contact A or contact B of the output can be used several times in the program, but the output should be used only once in the program. Otherwise, according to the program-scanning principle of the PLC, the state of the output depends on the circuit connected to the last output in the program.

- The output number (the decimal number)

For the PLC, the input numbers start from X0.0. The number of outputs varies with the number of outputs on the digital input/output modules, and the outputs are numbered according to the order in which the digital input/output modules are connected to the PLC. The maximum number of outputs on the PLC can reach up to 8192, and the range is between Y0.0 and Y511.15.

The output which is not practically put to use can be used as a general device.

- The output type

The outputs are classified into two types.

1. Regenerated output: Not until the program executes the instruction END is the information fed out according to the states of the outputs. For example, OUT Y0.0.
2. Direct output: When the instructions are executed, the information is fed out according to the states of the outputs. For example, OUT DY0.0.

### 5.2.6. Auxiliary Relays (M)

The auxiliary relay has contact A and contact B. It can be used several times in the program. You can combine the control loops by means of the auxiliary relay, but can not drive the external load by means of the auxiliary relay. The auxiliary relays can be divided into two types according to their attributes.

1. For general use: If an electric power cut occurs when the PLC is running, the auxiliary relay for general use will be reset to OFF. When the power supply is restored, the auxiliary relay for general use is still OFF.
2. For latched use: If an electric power cut occurs when the PLC is running, the state of the auxiliary relay for latched use will be retained. When the power supply is restored, the state remains the same as that before the electric power cut.

### 5.2.7. Special Auxiliary Relays (SM)

**SM:** special auxiliary relays

Every special auxiliary relay has its specific function. Please do not use the special auxiliary relays which are not defined.

For function descriptions of each special auxiliary relay (SM), refer to **Appendix 1: Special Auxiliary Relays Table of AH Motion Controller - Standard Instructions Manual**.

### 5.2.8. Data Registers (D)

The data register stores the 16-bit data. The highest bit represents either a positive sign or a negative sign, and the values which can be stored in the data registers range from -32,768 to +32,767. Two 16-bit registers can be combined into a 32-bit register, i.e. (D+1, D) in which the register whose number is smaller represents the low 16 bits. The highest bit represents either a positive sign or a negative sign, and the values which can be stored in the data registers range from -2,147,483,648 to +2,147,483,647. Besides, four 16-bit registers can be combined into a 64-bit register, i.e. (D+3, D+2, D+1, D) in which the register whose number is smaller represents the lower 16 bits. The highest bit represents either a positive sign or a negative sign, and the values which can be stored in the data registers range from -9,223,372,036,854,776 to +9,223,372,036,854,775,807.

The registers can be classified into two types according to their properties:

1. General-purpose register: If the PLC begins to run, or is disconnected, the value in the register will be cleared to zero. If you want to retain the data when the PLC begins to RUN, you can refer to ISPSOft User Manual for more information. Please notice that the value will still be cleared to zero if the PLC is disconnected.
2. Latched register: If the PLC is disconnected, the data in the latched register will not be cleared. In other words, the value before the disconnection is still retained. If you want to clear the data in the latched area, you can use RST or ZRST.

### 5.2.9. Special Data Registers (SR)

**SR:** special data registers.

Every special data register has its definition and specific function. The system statuses and the error messages are stored in the special data registers. Besides, the special data registers can be used to monitor the system statuses.

For function descriptions of each special data register (SR), refer to **Appendix 2: Special Data Registers Table of AH Motion Controller - Standard Instructions Manual**.

### 5.2.10. Link Registers (L)

The link register is mainly used in for automatic data exchange function. When the data exchange occurs between the AHxxEMC series PLCs, the link register can be used as the buffer.

The link registers L0~L65535 have 65536 words and can be used as the common auxiliary registers.

### 5.2.11. Stepping Relays (S)

The function of the stepping relay:

The stepping relay can be easily used in the industrial automation to set the procedure. It is the most basic device in the sequential function chart (SFC). Please refer to ISPSOft User Manual for more information related to sequential function charts.

There are 2048 stepping relays, i.e. S0~S2047. Every stepping relay is like an output relay in that it has an output coil, contact A, and contact B. It can be used several times in the program, but it can not directly drive the external load. Besides, the stepping relay can be used as a general auxiliary relay when it is not used in the sequential function chart.

### 5.2.12. Timers (T)

1. 100 millisecond timer: The timer specified by the instruction TMR takes 100 milliseconds as the timing unit.
2. 1 millisecond timer: The timer specified by the instruction TMRH takes 1 millisecond as the timing unit.
3. The timers for the subroutine's exclusive use are T1920~T2047.
4. The accumulative timers are ST0~ST2047. If you want to use the device-monitoring function, you can monitor T0~T2047.
5. If the same timer is used repeatedly in the program, including in different instructions TMR and TMRH, the setting value is the one that the value of the timer matches first.
6. If the same timer is used repeatedly in the program, it is OFF when one of the conditional contacts is OFF.
7. If the same timer is used repeatedly in the program as the timer for the subroutine's exclusive use and the accumulative timer in the program, it is OFF when one of the conditional contacts is OFF.
8. When the timer is switched from ON to OFF and the conditional contact is ON, the timer is reset and counts again.

9. When the instruction TMR is executed, the specified timer coil is ON and the timer begins to count. As the value of the timer matches the setting value, the state of the contact is as follows.

Normally open (NO) contact	ON
Normally closed (NC) contact	OFF

● **General-purpose timer**

When the instruction TMR is executed, the general-purpose timer begins to count. As the value of the timer matches the setting value, the output coil is ON.

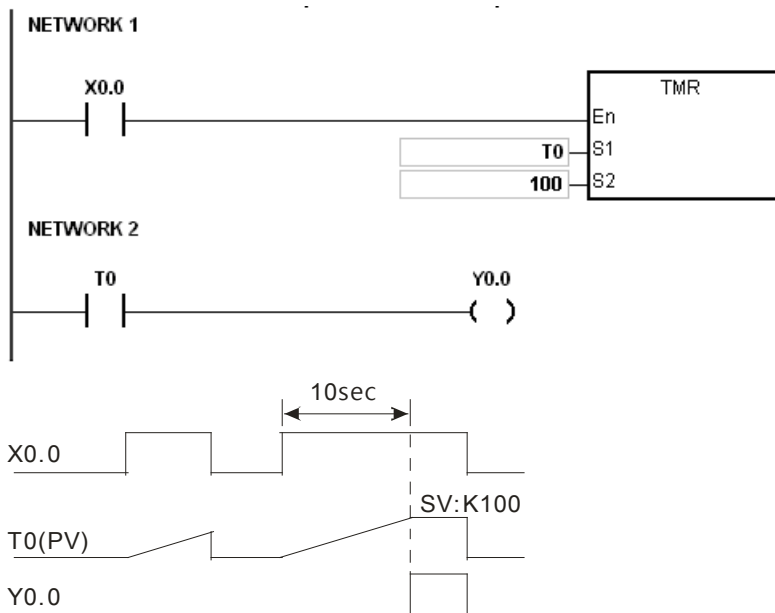

**5**

● **Accumulative timer**

When the instruction TMR is executed, the accumulative timer begins to count. As the value of the timer matches the setting value, the output coil is ON. As long as users add the letter S in front of the letter T, the timer becomes the accumulative timer. When the conditional contact is OFF, the value of the accumulative timer is not reset. When the conditional contact is ON, the timer will count from the current value.

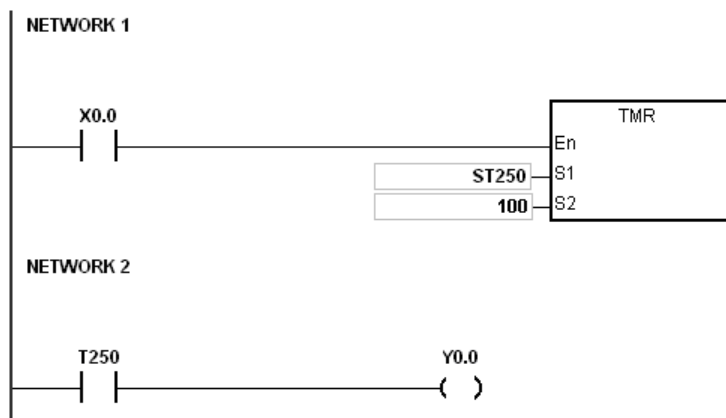

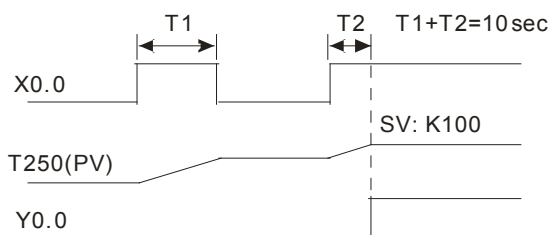

- **Timer used in the function block**

T1920~T2047 are the timers which users can use in the functional block or the interrupt.

When the instruction TMR or END is executed, the timer used in the functional block begins to count. As the value of the timer matches the setting value, the output coil is ON.

If the general-purpose timer is used in the functional block or the interrupt, and the functional is not executed, the timer can not count correctly.

### 5.2.13. Counters (C)

- **Specifications of the 16-bit counter**

Item	16-bit counter
Type	General type
Number	C0~C2047
Direction	Counting up
Setting value	0~32,767
Specification of the setting value	The setting value can be either the constant or the value in the data register.
Change of the current value	The counter stops counting when the value of the counter matches the setting value.
Output contact	The contact is ON when the value of the counter matches the setting value.
Reset	When the instruction RST is executed, the current value is cleared to zero, and the contact is reset of OFF.
Action of the contact	After the scan is complete, the contact acts.

- **The function of the counter:**

Each time the input switches from OFF to ON, the value of the counter increases by one increment. When the value of the counter matches the setting value, the output coil is ON. You can use either the decimal constant or the value in the data register as the setting value.

The 16-bit counter:

1. Setting range: 0~32,767 (The setting values 0 and 1 mean the same thing in that the output contact is ON when the counter counts for the first time.)
2. For the general-purpose counter, the current value of the counter is cleared when there is a power cut. If the counter is the latched one, the current value of the counter and the state of the contact before the power cut will be retained. The latched counter counts from the current value when the power supply is restored.
3. If you use the instruction MOV or ISPSofT to transmit a value bigger than the setting value to the current value register C0, the contact of the counter C0 will be ON and the current value will become the same as the setting value next time X0.1 is switched from OFF to ON.

4. You can use either the constant or the value in the register as the setting value of the counter.
5. The setting value of the counter can be a positive or a negative. If the counter counts up from 32,767, the next current value becomes -32,768.

### 5.2.14.32-bit Counters (HC/AC)

**HC:** The 32-bit general-purpose addition/subtraction counter

**AC:** The 32-bit counters used specifically for motion axis. The function of **AC** is the same as that of **HC**

● **Specifications of the 32-bit counter**

Item	32-bit counter
Type	General type
Number	HC0~HC63
Direction	Counting up/down
setting value	-2,147,483,648~+2,147,483,647
Specification of the setting value	The setting value can be either the constant or the value occupying two data registers.
Change of the current value	The counter keeps counting after the value of the counter matches the setting value.
Output contact	The contact is ON when the value of the addition counter matches the setting value. The contact is reset to OFF when the value of the subtraction counter matches the setting value.
Reset	When the instruction RST is executed, the current value is cleared to zero, and the contact is reset of OFF.
Action of the contact	After the scan is complete, the contact acts.

1. Setting range: -2,147,483,648~2,147,483,647
2. The switch between the 32-bit general-purpose addition counters and the 32-bit general-purpose subtraction counters depends on the states of the special auxiliary relays SM621~SM684. For example, the counter HC0 is the addition counter when SM621 is OFF, whereas HC0 is the subtraction counter when SM621 is ON.
3. You can use either the constant or the value in the data registers as the setting value of the counter, and the setting value can be a positive or a negative. If you use the value in the data registers as the setting value of the counter, the setting value occupies two consecutive registers.
4. For the general-purpose counter, the current value of the counter is cleared when there is a power cut. If the counter is the latched one, the current value of the counter and the state of the contact before the power cut will be retained. The latched counter counts from the current value when the power supply is restored.
5. If the counter counts up from 2,147,483,647, the next current value becomes -2,147,483,648. If the counter counts down from -2,147,483,648, the next current value becomes 2,147,483,647.

### 5.2.15. Index Registers (E)

The index register is the 16-bit data register. It is like the general register in that the data can be read from it and written into it. However, it is mainly used as the index register. The range of index registers is E0~E13.

Refer to **5.3.5 Modifying a Symbol with an Index Register** for more information.

### 5.2.16. Values and Constants (K, 16#)

- The explanation on data units which could be used in the system:

Name	Description
Bit	A bit is the basic unit in the binary system. Its state is either 1 or 0.
Nibble	A nibble is composed of four consecutive bits (e.g. b3~b0). Nibbles can be used to represent 0~9 in the decimal system, or 0~F in the hexadecimal system.
Byte	A byte is composed of two consecutive nibbles (i.e. 8 bits, b7~b0). Bytes can be used to represent 00~FF in the hexadecimal system.
Word	A word is composed of two consecutive bytes (i.e. 16 bits, b15~b0). Words can be used to represent 0000~FFFF in the hexadecimal system.
Double word	A double word is composed of two consecutive words (i.e. 32 bits, b31~b0). Double words can be used to represent 00000000~FFFFFFFF in the hexadecimal system.
Quadruple word	A quadruple word is composed of four consecutive words (i.e. 64 bits, b63~b0). Quadruple words can be used to represent 0000000000000000 – FFFFFFFFFFFFFFFF in the hexadecimal system.

The relation among bits, nibbles, bytes, words, and double words in the binary system is shown below.

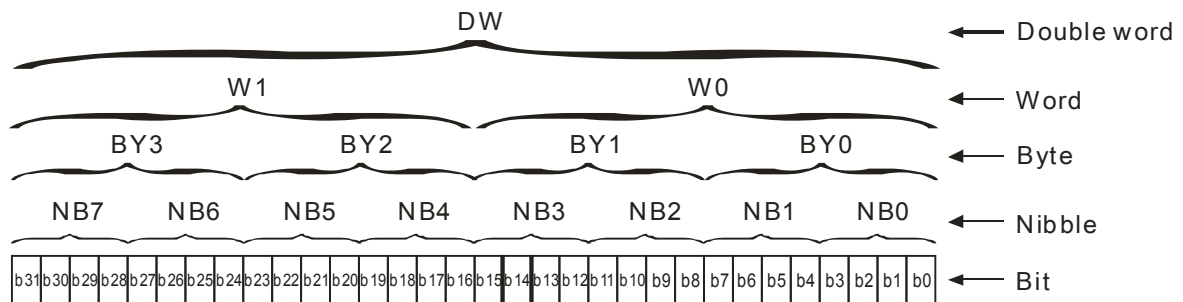

- The PLC uses four types of values to execute the operation according to different control purposes. The functions of these values are illustrated as follows:

#### 1. Binary number (BIN)

The PLC adopts the binary system to operate the values.

#### 2. Decimal number (DEC)

The decimal number in the PLC is used as;

- the setting value of the timer (T) or the setting value of the counter (C/HC). For example, TMR C0 50 (**constant K**).
- the device number. For example, M10 and T30 (device number)
- the number before or after the decimal point. For example, X0.0, Y0.11, and D10.0 (device number).
- **the constant K:** It is used as the operand in the applied instruction. For example, MOV 123 D0 (**constant K**).

#### 3. Binary-coded decimal (BCD)

A decimal value is represented by a nibble or four bits, and therefore sixteen consecutive bits can represent a four-digit decimal value.

#### 4. Hexadecimal number (HEX)

The hexadecimal number in the PLC is used as;

- **the constant 16#:** It is used as the operand in the applied instruction. For example, MOV 16#1A2B D0 (hexadecimal constant).

### 5.2.17. Floating-point Numbers (F, DF)

The floating-point numbers are represented by decimal points in ISPSOft. For example, the floating-point number of 500 is 500.0.

- **Single-precision Floating-point Numbers**

The floating-point number is represented by the 32-bit register. The representation adopts the IEEE754 standard, and the format is as follows.

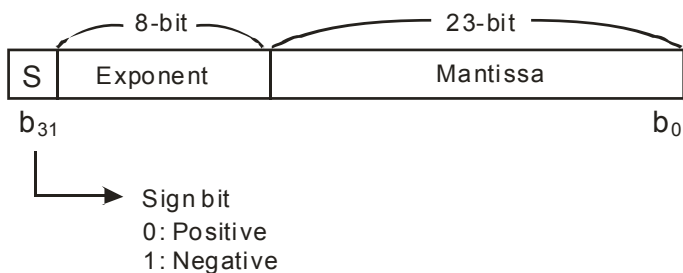

Equation:  $(-1)^S \times 2^{E-B} \times 1.M; B = 127$

The single-precision floating-point numbers range from  $\pm 2^{-126}$  to  $\pm 2^{+128}$ , and correspond to the range from  $\pm 1.1755 \times 10^{-38}$  to  $\pm 3.4028 \times 10^{+38}$ .

The AH500 series PLC uses two consecutive registers to form a 32-bit floating-point number. Take (D1, D0) for example.

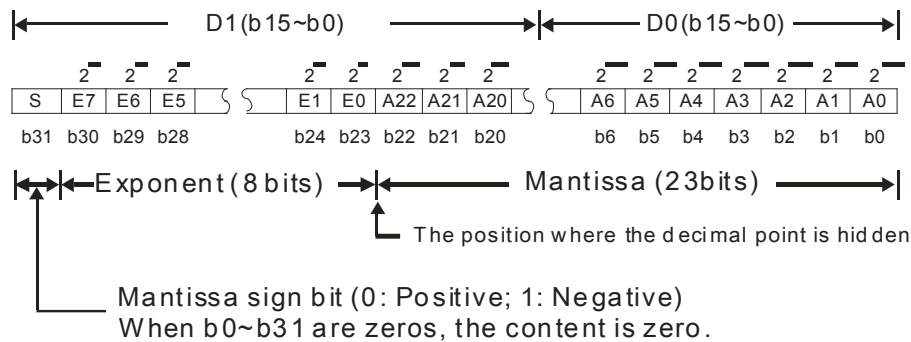

- **Double-precision Floating-point Numbers**

The floating-point number is represented by the 64-bit register. The representation adopts the IEEE754 standard, and the format is as follows.

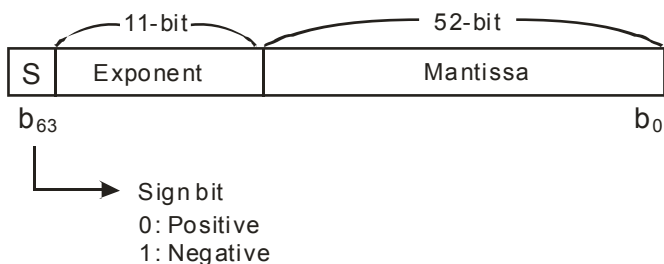

Equation:  $(-1)^S \times 2^{E-B} \times 1.M; B = 1023$

The double-precision floating-point numbers range from  $\pm 2^{-1022}$  to  $\pm 2^{+1024}$ , and correspond to the range from  $\pm 2.2250 \times 10^{-308}$  to  $\pm 1.7976 \times 10^{+308}$ .

The AH500 series PLC uses four consecutive registers to form a 64-bit floating-point number. Take (D3, D2, D1, D0) for example.

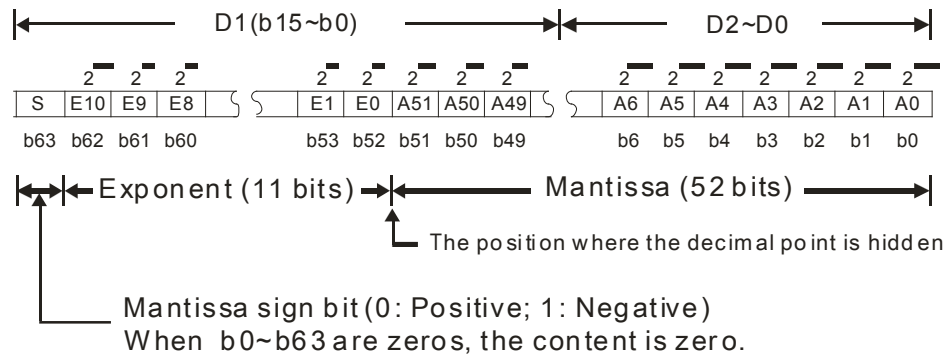

**Example 1:**

**23 is represented by the single-precision floating-point number.**

Step 1: Convert 23 into the binary number, i.e.  $23.0 = 10111$ .

Step 2: Normalize the binary number, i.e.  $10111 = 1.0111 \times 2^4$  (0111 is the mantissa, and 4 is the exponent.).

Step 3: Get the value of the exponent.

$\therefore E - B = 4 \rightarrow E - 127 = 4 \therefore E = 131 = 10000011_2$

Step 4: Combine the sign bit, the exponent, and the mantissa to form the floating-point number.

$0\ 10000011\ 011100000000000000000000_2 = 41B80000_{16}$

**23 is represented by the double-precision floating-point number.**

Step 1: Convert 23 into the binary number, i.e.  $23.0 = 10111$ .

Step 2: Normalize the binary number, i.e.  $10111 = 1.0111 \times 2^4$  (0111 is the mantissa, and 4 is the exponent.).

Step 3: Get the value of the exponent.

$\therefore E - B = 4 \rightarrow E - 1023 = 4 \therefore E = 1027 = 10000000011_2$

Step 4: Combine the sign bit, the exponent, and the mantissa to form the floating-point number.

$0\ 10000000011\ 011100_2 = 40370000000000_{16}$

**Example 2:**

**-23 is represented by the single-precision floating-point number.**

The steps of converting -23.0 into the floating-point number are the same as those of converting 23.0 into the floating-point number, except that the sign bit is 1.

$1\ 10000011\ 011100000000000000000000_2 = C1B80000_{16}$

**-23 is represented by the double-precision floating-point number.**

The steps of converting -23.0 into the floating-point number are the same as those of converting 23.0 into the floating-point number, except that the sign bit is 1.





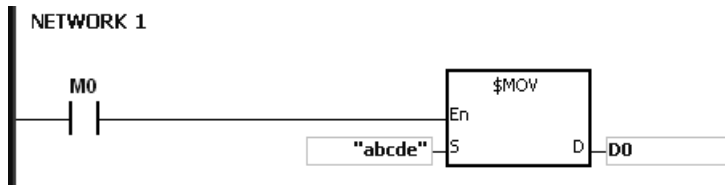

D0	16#62 (b)	16#61 (a)
D1	16#64 (d)	16#63 (b)
D2	0 (NULL)	16#65 (e)

\*1: ASCII code chart

Hex	0	1	2	3	4	5	6	7	8	9	A	B	C	D	E	F
ASCII	☒	☒	☒	☒	☒	☒	☒	☒	☒	☒	☒	☒	☒	☒	☒	☒
Hex	10	11	12	13	14	15	16	17	18	19	1A	1B	1C	1D	1E	1F
ASCII	☒	☒	☒	☒	☒	☒	☒	☒	☒	☒	☒	☒	☒	☒	☒	☒
Hex	20	21	22	23	24	25	26	27	28	29	2A	2B	2C	2D	2E	2F
ASCII	SP	!	"	#	\$	%	&	'	(	)	*	+	.	-	.	/
Hex	30	31	32	33	34	35	36	37	38	39	3A	3B	3C	3D	3E	3F
ASCII	0	1	2	3	4	5	6	7	8	9	:	;	<	=	>	?
Hex	40	41	42	43	44	45	46	47	48	49	4A	4B	4C	4D	4E	4F
ASCII	@	A	B	C	D	E	F	G	H	I	J	K	L	M	N	O
Hex	50	51	52	53	54	55	56	57	58	59	5A	5B	5C	5D	5E	5F
ASCII	P	Q	R	S	T	U	V	W	X	Y	Z	☒	☒	☒	☒	☒
Hex	60	61	62	63	64	65	66	67	68	69	6A	6B	6C	6D	6E	6F
ASCII	`	a	b	c	d	e	f	g	h	i	j	k	l	M	n	o
Hex	70	71	72	73	74	75	76	77	78	79	7A	7B	7C	7D	7E	7F
ASCII	p	q	r	s	t	u	v	w	x	y	z	{		}	~	☒

Note: ☒ represents an invisible character. Please do not use it.

## 5.3. EtherCAT Symbols

The EtherCAT symbols are used to read states of EtherCAT slave. The symbols can be seen from the EtherCAT symbol table in the ISPSOft software.

EtherCAT Symbol	Data type	Description	Range	Default settings
eCAT_Dis.SlaveAddress[...]	WORD[199]	The EtherCAT slave address that disconnected (n=0~198)	0~9999	0
eCAT_Dis.Count	WORD	The number of EtherCAT slave address that disconnected	0~ ( 2 <sup>16</sup> -1 )	0

## 5.4. Symbols

During the process of developing a traditional program for a PLC, it generally takes much time to manage device addresses. Besides, managing or debugging the program in a big project is a burden on users. As a result, the concept of symbols\* in a high-level programming language is introduced by IEC 61131-3. A device in a PLC can be represented by a symbol, and a device can be automatically assigned to a symbol. In this way, the time to assign devices is saved, the program is more readable, and the efficiency of developing a program increases.

**\*Note:** Variables in ISPSOft are called symbols. As a result, variables are the same as symbols in terms of meaning in this manual.

### 5.4.1 Application of Symbols

A symbol has to be declared before it is used. There are two types of symbols. They are global symbols and local symbols. The global symbols in a project can be used in all the POU\*s in the project, and the local symbols in a project can only be used in the POU in which the local symbols are declared. Besides, the identifier of a local symbol in a POU can be the same as the identifier of a local symbol in another POU. However, if this local symbol identifier is the same as a global symbol identifier, the system will automatically regard it as a local symbol.

**\*Note:** For further explanations regarding a POU, refer for **ISPSOft User Manual**.

### 5.4.2 Classes

Symbols can be categorized into four classes. The features of the four classes are described below.

- **VAR - General symbol**

The symbols of this class are for general operations only. The significance of a symbol of this class depends on the data type of the symbol.

- **INPUT - Symbol used as an input pin of a function block**

A symbol of this class is used as an input pin of a function block. It can only be declared in the function block. If a function block is called, the symbols of this class can receive the input values sent by the caller. In a ladder diagram, INPUTs are put at the left sides of function blocks with pins receiving the input values sent by the caller.

- **OUTPUT - Symbol used as an output pin of a function block**

A symbol of this class is used as an output pin of a function block. It can only be declared in a function block. After the execution of a function block is complete, the operation results will be sent to the caller through the symbols of this

class. In a ladder diagram, OUTPUTs are put at the right sides of function blocks with pins sending the operation results to the caller.

- **INOUT - Symbol used as a feedback pin of a function block**

A symbol of this class is used as a feedback pin of a function block. It can only be declared in the function block. Please refer to the following example. When the function block is called, the caller sends the value in D1 to DT\_IO, which is a symbol of the INOUT class. After the operation comes to an end, the final value of DT\_IO is sent to D1. In a ladder diagram, the symbols of this class are put at the left sides of function blocks.

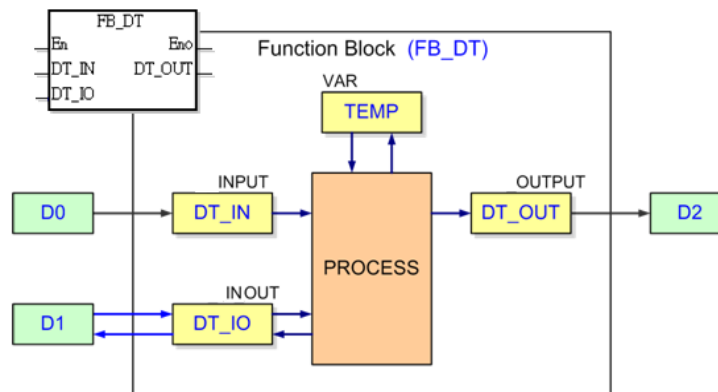

### 5.4.3 Data Types

The data type of a symbol determines the format of the value of the symbol. Suppose there are two symbols `VAR_1` and `VAR_2`. The data type of `VAR_1` is `BOOL`, and the data type of `VAR_2` is `WORD`. If `VAR_1` and `VAR_2` are used in a program, `VAR_1` will represent a contact, and `VAR_2` will represent a 16-bit device which can be involved in arithmetic operation or transferring the data.

The data types supported by ISPSOft are listed below.

Data type	Name	Description	Program	Function block
BOOL	Boolean	A Boolean value represents the state of a contact, could be TRUE or FALSE.	✓	✓
WORD	Word	Bit string of length 16.	✓	✓
DWORD	Double Word	Bit string of length 32.	✓	✓
LWORD	Long Word	Bit string of length 64.	✓	✓
UINT	Unsigned integer	16-bit data.	✓	✓
UDINT	Unsigned double integer	32-bit data.	✓	✓
INT	Integer	16-bit data	✓	✓
DINT	Double integer	32-bit data.	✓	✓
LINT	Long Integer	64-bit data.	✓	✓
REAL	Real numbers	32-bit data; applicable to single precision floating-point instructions.	✓	✓
LREAL	Long reals	64-bit data; applicable to double precision floating-point instructions.	✓	✓
CNT	Counter	16-bit counter value or 32-bit counter value.	✓	✓
TMR	Timer	16-bit timer value.	✓	✓

Data type	Name	Description	Program	Function block
ARRAY	Array	If a symbol is declared as an array, the size of an array and an array data type must be specified. (An array is composed of 256 elements/members at most.)	✓	✓
String	Character string	Variable-length single-byte data string. 8 bits as one ASCII character. The string length needs to be specified on declaration.	✓	✓

### 5.4.4 Using Devices, Symbols and Instructions

A device is assigned to a symbol according to the data type of the symbol. You can set the initial value of the device. After the program in a project is downloaded to a motion controller, the initial values will be written into the devices assigned to the symbols at the first scan cycle.

The principles of assigning devices to symbols are as follows.

- Devices can be assigned to the global symbols and the local symbols declared in the program POU by users, or assigned automatically by system.
- Local symbols (except the symbols of VAR class) declared in a function block can only be assigned with devices by the system.
- The system will assign applicable devices only. (You can set a range of devices which can be assigned automatically.)
- If a symbol is declared, the device assigned to the symbol, the data type of the symbol, and the initial value of the symbol must be compatible with one another.

The relation between the data types and the device types which can be assigned is described below.

Data type	AH Motion Controller CPU	
	Device assigned by users	Device assigned by the system
BOOL	Contact M/SM or bit in the device X/Y (*3)	Contact M/SM
WORD	D	W
DWORD	D	W
LWORD	D	W
UINT	D	W
UDINT	D	W
INT	D	W
DINT	D	W
LINT	D	W
REAL	D	W
LREAL	D	W
CNT	C	C
TMR	T	T
ARRAY	`The devices assigned to a symbol whose data type is ARRAY depend on the array type specified. An array is composed of the devices starting from the device assigned by users or the system, and the	

Data type	AH Motion Controller CPU	
	Device assigned by users	Device assigned by the system
	number of devices in an array conforms to the size of the array.	
String	N/A	

\*1. Please refer to *ISPSOft User Manual* for more information about setting a range of devices which can be assigned automatically.

\*2. A symbol representing a function block definition has a special significance. Please refer to *ISPSOft User manual* for more information.

\*3. X0.0 and Y0.1 are bits in the word devices X and Y. Please refer to *ISPSOft User manual* for more information.

### 5.4.5 Modifying a Symbol with an Index Register

You are allowed to use index registers (E device) in ISPSOft to modify a symbol. The E devices are like general 16-bit data registers. You can write data into the E devices and read data from the E devices freely. If a E device is used as a general register, it can only be used in a 16-bit instruction. The modification of a symbol by an index register is represented by the format: **Identifier@Index register**. If an E device is used to modify an operand, it can be used in a 16-bit instruction or a 32-bit instruction.

Please refer to the program below. The device assigned to VAR\_0 is D0. The data stored in an index register indicates the offset for the symbol which the index register modifies. If the value in the index register E0 is 2, VAR\_0@ E0 indicates that 2 is added to the device address (D0) assigned to VAR\_0, that is, VAR\_0@E0 represents D2. If M0 is ON, the value in E0 will be 2, the value in E1 will be 3, and the value in D2 will be moved to D103.

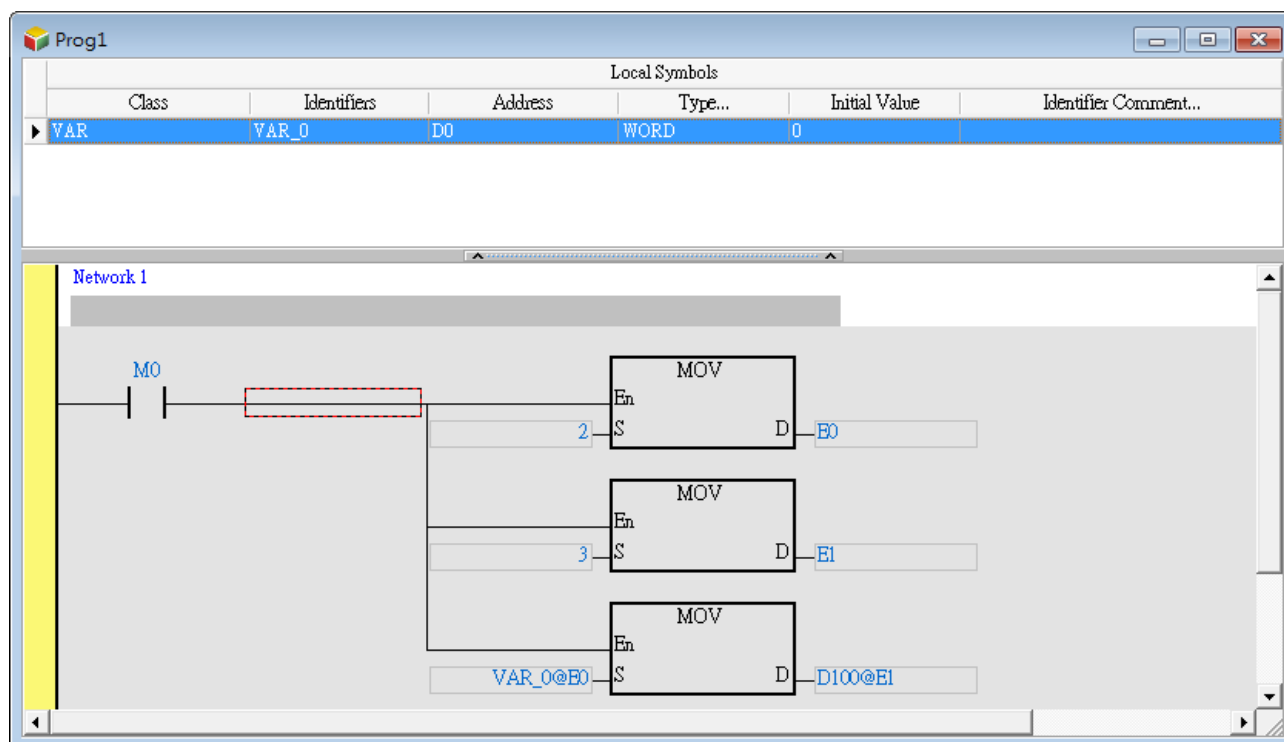

Besides, if the value in an index register is changed, the device which actually operates differs from the original device. As a result, if the original device is not used in the program, the final value in the original device is retained. In the figure below, if the value in E0 is 3, the value in D2 will be moved to D103. When the value in E0 is changed from 3 to 4, the value in D2 will be moved to D104, and the value in D103 will remain unchanged.

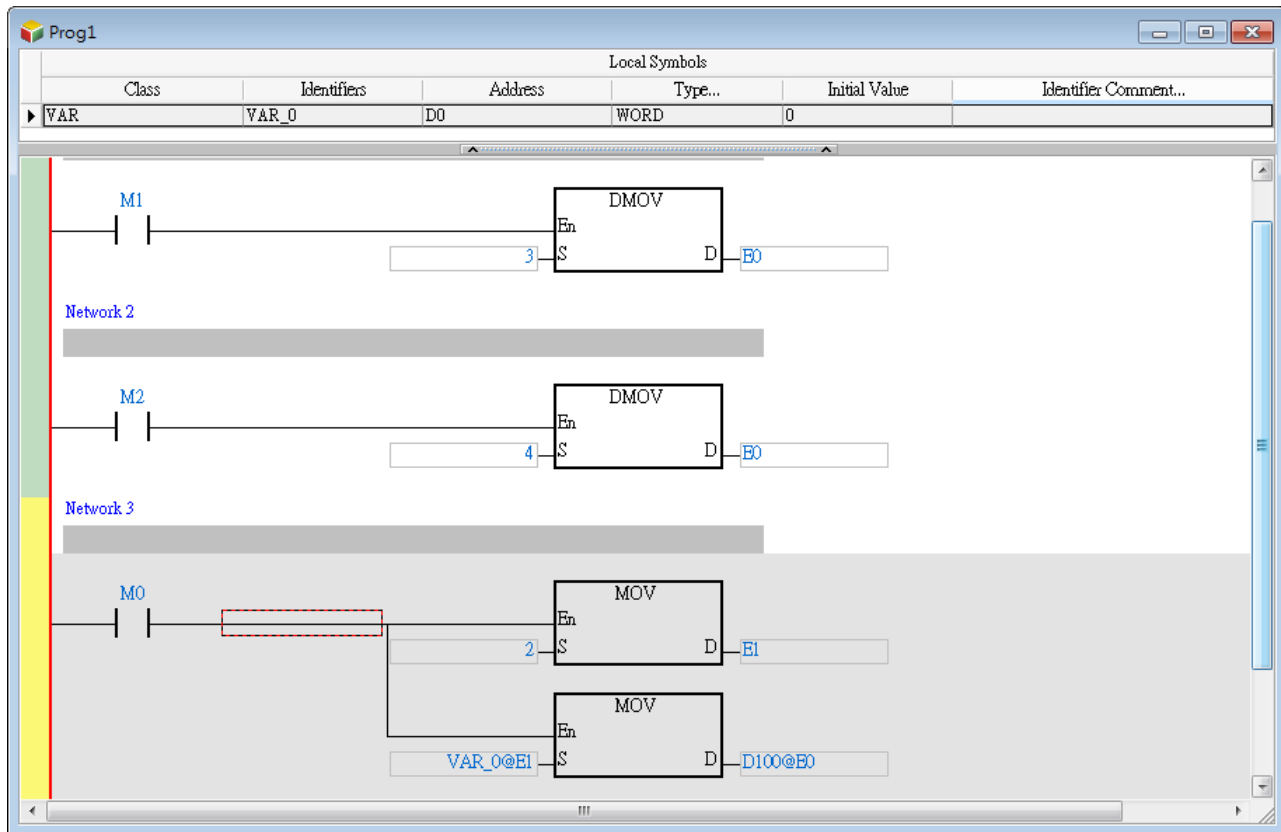

\*1. The data stored in an index register indicates the offset for the device which the index register modifies. If the system automatically assigns a device to a symbol, the use of an index register to modify the symbol will cause the program to be executed incorrectly because users do not know which device is assigned to the symbol.

5

\*2. If you want to assign index registers to symbols, you have to specify device addresses and data types.

## 5.5. User-defined Data Type (ENUM)

You can also use the user-defined data type for enumeration (ENUM). ENUM is a derivative data type which defines the ENUM symbol with its elements and the associated values. You can specify the initial value to an element, and use one of the enumerated values in the associated elements list. The list defines an ordered set of values in series, starting with the first element and ending with the last one. You can use the same element in different ENUM symbols.

The rules for specifying the elements and the values for an ENUM symbol:

- If elements are not specified, the initial value will be 0, and following 1, and etc.
- When elements are specified with initial values, the initial value of the element will be changed. The enumerated values before the element is defined with an initial value remain unchanged. For example, 0, 1, 2 (not defined), 35(the defined initial value), 36, 37, and etc.
- Another example when the element is defined twice: 0, 1, 2 (not defined), 35(first defined value), 36, 70(second defined value), 71, and etc.

- The two setting methods:

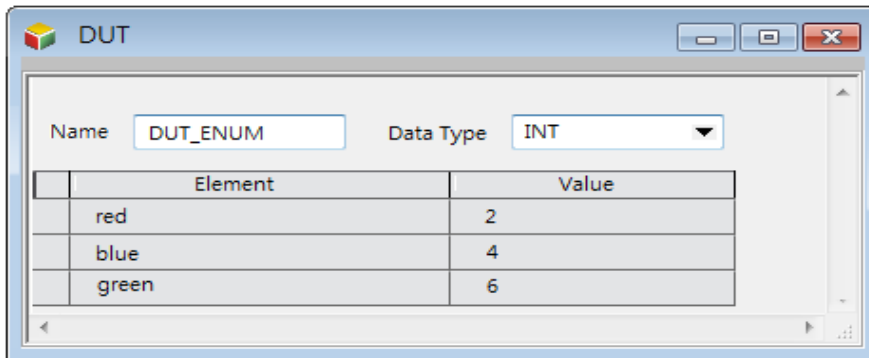

Declare by the setting table

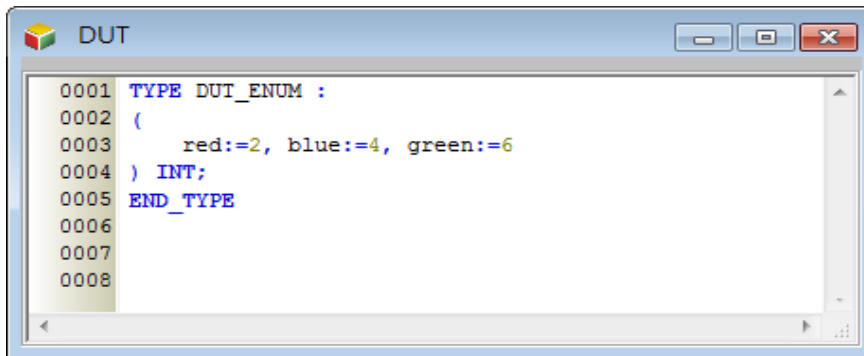

Declare by texts

For more information about the software operation, refer to *ISPSoft User Manual*.



**MEMO**

---

# Chapter 6 Understanding Motion Control Devices

## Table of Contents

- 6.1 Motion Control Devices.....6-2**
- 6.1.1 Structures Applicable for Motion Control .....6-2
- 6.1.2 Parameters for Motion Axes.....6-2

## 6.1 Motion Control Devices

Motion control devices are mainly used for configuring parameters for motion axis. In most applications, you can set up axis parameters in ISPSOFT software, which is a convenient environment for users. In PLCopen technical standard, the information and parameters required for configuring motion control on axis are defined as Structures. A structure is a data type applicable to group the data elements together. You can refer to *ISPSOFT User Manual* for the operation of using structures.

### 6.1.1. Structures Applicable for Motion Control

For AH Motion Controller CPUs, the applicable Structure are as below.

Structures		Definition
PLCopen	Motion FBs	
AXIS_REF*	Applicable for MC_ / DFB_ function blocks	Information and parameters required for configuring axis motion is grouped in this Structure.
AXES_GROUP_REF	N/A	Information and parameters required for configuring axes group motion is included in this Structure.
TRIGGER_REF	MC_TouchProbe MC_AbortTrigger	Information on trigger inputs <ul style="list-style-type: none"> <li>● Specifications of the trigger</li> <li>● Trigger activation patterns (rising-edge, falling edge, and etc.)</li> </ul>
INPUT_REF	N/A	Information relating to the inputs. Virtual data could be included.
OUTPUT_REF	N/A	Information relating to physical outputs.

\*Note: refer to the **6.1.2 Parameters for Motion Axes** of this manual for the list of parameters grouped in the Structure AXIS\_REF which is supported by AH Motion Controller CPU.

### 6.1.2. Parameters for Motion Axes

For AH Motion Controller CPUs, the applicable structure for setting up **axis parameters** is AXIS\_REF. The below table can be used in case there is a need to change axis parameters by modifying specific data registers. The detailed explanation also helps you to have a proper understanding of the axis parameters.

- **The axis parameters for motion axes**

AXIS_REF		Description		
Members	Data type	Function	Setting range	Factory setting (Default)
Parm_setting	WORD	Setting the parameters of the axis specified	Bit 0~bit15	0
Pulse_of_1Rev	DINT	Number of pulses it takes for the motor of the axis specified to rotate once	1~99999999 pulses/revolution	10,000
Parm_setting	32 DINT	Distance generated after the motor of the axis specified rotate once	1~1000000	10,000

AXIS_REF		Description			
Members		Data type	Function	Setting range	Factory setting (Default)
Pulse_of_1Rev	64	LREAL		Userunit/revolution	
Maximum_Speed	32	DINT	Maximum speed ( $V_{MAX}$ ) at which the axis specified rotates	0~2,147,483,647	100,000
Max_Speed_f	64	LREAL			
Start_up_speed	32	DINT	Start-up speed ( $V_{BIAS}$ ) at which the axis specified rotates	0~100,000	0
Start_up_speed_f	64	LREAL			
JOG_speed	32	DINT	JOG speed ( $V_{JOG}$ ) at which the axis specified rotates	0~( $2^{31}-1$ )	5,000
Target_JOG_speed_f	64	LREAL		0~1.7976931348* ( $10^{308}$ )	5,000
Homing_speed_for_switch		DINT	Speed ( $V_{RT}$ ) at which the axis specified returns home (0.1RPM)	0~2,147,483,647	2,000
Homing_speed_for_zero		DINT	Speed ( $V_{CR}$ ) to which the speed of the axis specified decreases when the axis returns home (0.1RPM)	0~2,147,483,647	100
Homing_position		DINT	Home position of the axis specified (User Unit)	$-(2^{31})\sim(2^{31}-1)$	0
Max_Accelerate_time		INT	Maximum acceleration time (TACC); unit: ms	0~1,000 ms	500
Max_Decelerate_time		INT	Maximum deceleration time (TDEC); unit: ms	0~1,000 ms	500
Target_command_position1	32	DINT	Target position of the axis specified (User Unit)	$-(2^{31})\sim(2^{31}-1)$	0
Target_command_position_f	64	LREAL		$(+/-)1.7976931348*(10^{308})$	
Target_command_speed1	32	DINT	Speed at which the axis specified rotates (User Unit)	0~( $2^{31}-1$ )	0
Target_command_speed_f	64	LREAL		0~1.7976931348* ( $10^{308}$ )	
Current_command_position_UU		DINT	Present command position of the axis specified (User Unit)	$-(2^{31})\sim(2^{31}-1)$	0

AXIS_REF		Description			
Members		Data type	Function	Setting range	Factory setting (Default)
Current_command_position_UU_f	64	LREAL		( +- ) 1.7976931348* ( 10 <sup>308</sup> )	0
Current_actual_speed	32	DINT	Present command speed of the axis specified (User Unit/S)	0~(2 <sup>31</sup> -1) PPS	0
Current_actual_speed_UUperS_f	64	LREAL		0~1.7976931348* (10 <sup>308</sup> )	0
Position_Lim_Positive_f		LREAL	Positive direction position limit (User Unit)	0~1.7976931348* (10 <sup>308</sup> )	2,147,483,647
Position_Lim_Negative_f		LREAL	Negative direction position limit (User Unit)	0~-1.7976931348* (10 <sup>308</sup> )	2,147,483,647
Max_Acceleration_f		LREAL	Maximum Acceleration (User Unit /S <sup>2</sup> )	0~1.7976931348* (10 <sup>308</sup> )	1,000
Target_command_Acceleration_F		LREAL	Target acceleration of the axis specified (User Unit /S <sup>2</sup> )	0~1.7976931348* (10 <sup>308</sup> )	1,000
Max_Deceleration_f		LREAL	Maximum Dcceleration (User Unit /S <sup>2</sup> )	0~1.7976931348* (10 <sup>308</sup> )	1,000
Target_command_Deceleration_f		LREAL	Target deceleration of the axis specified (User Unit /S <sup>2</sup> )	0~1.7976931348* (10 <sup>308</sup> )	200,000
Target_command_Jerk_f		LREAL	Target jerk of the axis specified (User Unit /S <sup>3</sup> )	0~1.7976931348* (10 <sup>308</sup> )	0
Max_position_of_Rotary_Axis_f		LREAL	Maximum position of rotational axis (User Unit )	0~2,147,483,647	2,147,483,647
Min_position_of_Rotary_Axis_f		LREAL	Minimum position of rotational axis (User Unit )	-2,147,483,647~0	-2,147,483,647
Current_Axis_error_code		WORD	Axis error code	Please refer to the error code tables in appendix A.	0
Egear_ratio_Numerator		INT	Electronic gear ratio of the axis specified (Numerator)	1~99,999,999	128
Egear_ratio_Denominator		INT	Electronic gear ratio of the axis specified (Denominator)	1~99,999,999	1
Electrical_zero		DINT	Electrical zero of the axis specified	Users can set the value according to their needs.	0

AXIS_REF	Description			
Members	Data type	Function	Setting range	Factory setting (Default)
StateMachine_AxisStatus*1	WORD	State of the designed axis	Refer to the table below	2

\*1: State of the designed axis

Axis number	Description
2	Disabled
3	Standstill
4	Homing
5	Stopping
6	ContinuousMotion
7	SynchronizedMotion
8	DiscreteMotion
9	Coordinated
10	CoordinatedHalt
11	CoordinatedStop

**MEMO**

---

## Chapter 7 Motion Control Programming

### Table of Contents

<b>7.1</b>	<b>Introduction .....</b>	<b>7-2</b>
7.1.1	Program Organization Units and Tasks .....	7-2
<b>7.2</b>	<b>Motion Control Program .....</b>	<b>7-3</b>
7.2.1	Program Architecture and Types in ISPSOft .....	7-3
7.2.2	POUs in ISPSOft .....	7-4
7.2.3	Managing the Tasks in ISPSOft .....	7-4
<b>7.3</b>	<b>Motion Control Instructions.....</b>	<b>7-5</b>
7.3.1	Function Blocks for AH Motion Controller CPU .....	7-5
<b>7.4</b>	<b>Axis .....</b>	<b>7-7</b>
<b>7.5</b>	<b>State Transitions .....</b>	<b>7-10</b>
7.5.1	Axis States.....	7-10
7.5.2	Axis Group State.....	7-11
<b>7.6</b>	<b>Buffer Mode.....</b>	<b>7-12</b>
<b>7.7</b>	<b>Execution of Function Block Instructions .....</b>	<b>7-17</b>
7.7.1	The Interface of a Motion Control Function Block .....	7-17
7.7.2	Timing Diagram for Input/Outputs.....	7-20
<b>7.8</b>	<b>Positions.....</b>	<b>7-21</b>
7.8.1	Position Types .....	7-21
7.8.2	Applicable Positions for Each Axis Type .....	7-21
<b>7.9</b>	<b>Electronic Cam.....</b>	<b>7-21</b>
7.9.1	Introduction of Electronic Cams.....	7-21
7.9.2	Operation of an Electronic Cam .....	7-22
7.9.2.1	Initial Setting .....	7-23
7.9.2.2	Setting a Master/Slave Axis and Operating an Electronic Cam .....	7-24
7.9.2.3	Starting/Stopping an Electronic Cam Operating Cyclically .....	7-28
7.9.3	Creating Electronic Cam Data .....	7-31
7.9.3.1	Creating a CAM Chart in ISPSOft .....	7-31
7.9.4	Application of an Electronic Cam—Using a Rotary Cutter.....	7-40
7.9.4.1	Creating Rotary Cut Data .....	7-43



## 7.1 Introduction

Program organization units (POUs) and tasks are important programming concepts related to IEC 61131-3. They upgrade programming from traditional program writing to project management.

For details about the software operation and programming, please refer to *ISPSoft User Manual*.

### 7.1.1 Program Organization Units and Tasks

#### ● Program Organization Units (POUs)

Program organization units are basic elements of a program in a PLC. They are different from a traditional program in a PLC. The characteristic of the program architecture introduced by IEC 61131-3 is that a program is divided into several units. These units are called program organization units.

There are three types of POUs: programs (PROGs), function blocks (FBs), and function POUs.

##### ● Program (PROG):

A POU of the program type is the main program unit in a project. A program POU executes according to the task to which it is assigned, either a cyclic program or an interrupt subroutine. The scan order of Program POUs can be arranged in the task list.

##### ● Function block (FB):

A POU of the function block type is similar to a subroutine program. The process defined in the function block will be executed only when proper parameters are specified to the FB and the FB is called by a program.

##### ● Function POU

A Function POU represents close to a macro instruction that allows you to write multiple operation commands in the function POU. Function POU is available to be called by PROG or FB in the main program.

**Note:** ISPSoft only supports single function (noted as FC in *AH Motion Controller – Standard Instructions Manual*), which refers to an API(applied instruction) in the software. Function POU is currently not supported by ISPSoft.

#### ● Tasks

Every program POU is assigned to a specific task. The tasks determine the order in which the program POU are executed or enabled.

The characteristic of the IEC 61131-3 architecture is that a program is divided into several POUs which can be developed independently. When all POUs are compiled, they are rearranged and combined into an execution code which can be scanned step by step. The POUs are rearranged and combined according to the tasks to which the POUs are assigned.

There are three types of tasks. They are cyclic tasks, timed interrupt tasks, and conditional interrupt tasks.

##### ● Cyclic task

A program POU assigned to a cyclic task is scanned back and forth.

##### ● Timed interrupt task

A program POU assigned to a timed interrupt task is like a timed interrupt subroutine. If the time when timed interrupts should occur is reached, the POUs assigned to the timed interrupt task will be executed in order.

##### ● Conditional interrupt task

There are several types of conditional interrupt tasks. For example, external interrupts, I/O interrupts, counting interrupts, and etc. Different PLCs provide different conditional interrupt tasks. You have to make sure of the conditional interrupt

tasks which are supported by the PLC before you assign the POU of the program type to tasks. A POU of the program type which is assigned to a conditional interrupt task is like an interrupt subroutine. If the condition of an interrupt is met, e.g. the value of a counter reaches the setting value, the POU assigned the interrupt task will be executed in order.

## 7.2 Motion Control Program

### 7.2.1 Program Architecture and Types in ISPSOft

In the classic architecture, a source code for a PLC is composed of all procedures, including subroutines. If the size of a program becomes larger, the maintenance of the program and the debugging of the program will be a burden. In the IEC 61131-3 architecture, a program is divided into several units according to the functions or characteristics. It is convenient to develop and maintain a program. Because program organization units are modular units, different program organization units can be developed by different designers. It benefits the distribution of manpower and the execution of the project.

There are two types of POU in ISPSOft. They are programs (PROGs) and function blocks (FBs).

#### • Program (PROG)

A POU of the program type plays a role according to the task to which it is assigned. If a program POU is assigned to a cyclic task, the POU of the program type acts as a main program. If the POU of the program type is assigned to an interrupt task, the POU of the program type acts as a subroutine. In addition, a POU of the program type can call a function block (FB).

#### • Function block (FB)

A static symbol can be declared in a function block (FB). As a result, the value of the symbol after an operation can be retained. Because the operation is performed on the value memorized in the function block and an input value, the output values may be different even if the input values are the same. In addition, a function block can call another function block.

The relation among POU is shown below. Note that ISPSOft presently does not support a Function POU, and the FC noted here refers to a single function which is referred to an API (applied instruction) in the system.

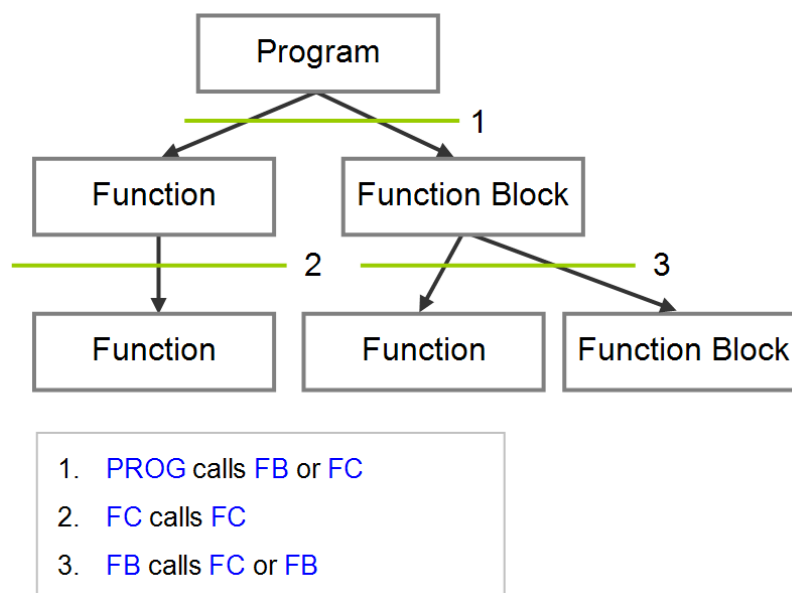

## 7.2.2 POU in ISPSOft

All POU created by users are listed in the program management area. The POU of the program type and the POU of the function block type are managed separately. Besides, the programming language in which a POU is written determines the icon representing the POU, and the information about the POU is put at the end of the POU name.

After a POU in the project management area is double-clicked, a POU editing window will appear. The POU editing window is composed of two parts. A table of local symbols is at the upper part of the window, and the body of a program is at the lower part of the window. Besides, the editing environment at the lower part of the window varies with the programming language used. Please refer to the following sections for more information about symbol tables and program editing.

## 7.2.3 Managing the Tasks in ISPSOft

In ISPSOft, not all the POU of the program type in the project are executed. A POU of the program type will be executed after it is assigned to a task, and the task determined how the POU is executed. If a POU is not assigned to a task, the POU will be taken as a general source code, will be saved with the project, and will not be translated into an execution code. Besides, only POU of the program type need to be assigned to tasks, and function blocks are called by POU.

In ISPSOft, a POU of the program type is assigned to a task. However, more one POU can be assigned to the same task, and the order in which these POU are executed can be specified. Besides, after you add a POU of the program type, you must assign it to a default task.

There are three types of tasks. They are cyclic tasks, timed interrupt tasks, and conditional interrupt tasks.

- **Cyclic task**

A POU assigned to a cyclic task is scanned back and forth. There are 32 cyclic tasks in a project for an AH series CPU. These cyclic tasks are numbered from 0 to 31. The smaller the task number is, the earlier the task is executed. Besides, AH series CPUs support the API (applied instructions) TKON and TKOFF which control tasks. You can enable or disable a task during the operation of an AH series CPU.

A POU is which a sequential function chart can only be assigned to a cyclic task. It can not be assigned to an interrupt task.

- **Timed interrupt task**

A POU of the program type which is assigned to a timed interrupt task is like a timed interrupt subroutine. If the time when timed interrupts should occur is reached, the POU assigned to the timed interrupt task will be executed in order. Besides, the number of timed interrupt tasks depends on a PLC selected. The number of interrupt triggers that a PLC supports is the available number of timed interrupt tasks that can be used in the software.

- **Conditional interrupt task**

There are several types of conditional interrupt tasks. For example, external interrupts, I/O interrupts, counting interrupts, and etc. Different PLCs provide different conditional interrupt tasks. You have to make sure of the conditional interrupt tasks which are supported by the PLC before you assign the POU of the program type to tasks. A POU of the program type which is assigned to a conditional interrupt task is like an interrupt subroutine. If the condition of an interrupt is met, e.g. the value of a counter reaches the setting value, the POU assigned the interrupt task will be executed in order.

## 7.3 Motion Control Instructions

To perform motion control function, you will need to use motion control instructions which are mostly function block POUs provided by AH Motion Controller CPU. In AH Motion Controller system, the naming of function blocks has two types. One is DFB instruction (Delta Function Block), which is developed by Delta to enhance the usability. Another one is MC, which complies with the motion control function block standard defined by PLCopen.

For details of motion control instructions, refer to **AH Motion Controller – Motion Control Instructions Manual**

### 7.3.1 Function Blocks for AH Motion Controller CPU

- **DFB ( Delta Function Block) instructions**

DFB instructions are Delta-defined instructions categorized as single-axis, multi-axis, auxiliary, network, and field application instructions. These instructions are provided for achieving various control purposes.

- **MC instructions**

PLCopen standardizes the motion control function block interface in IEC 61131-3. MC instructions provided by Delta comply with the PLCopen standard and make the user program less hardware-dependant and highly-reusable among different controllers. This feature reduces the time and effort on developing, tuning and maintaining the control system.

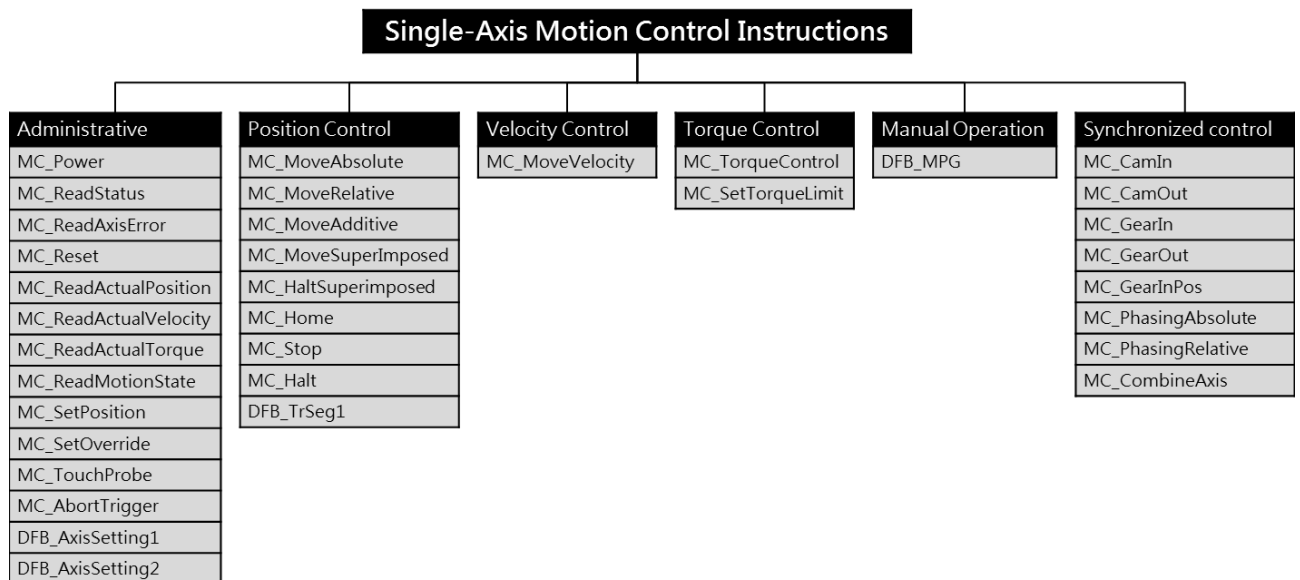

### Multi-Axis Motion Control Instructions

Administrative
DFB_GroupEnable
DFB_GroupDisable
DFB_GroupReset
DFB_ReadGroupStatus

Group Motion
DFB_GroupAbsLinear
DFB_GroupRelLinear
DFB_GroupAbsCircular
DFB_GroupRelCircular
DFB_GroupStop
DFB_GroupImmediateStop

G-Codes
DFB_GcodeSetting
DFB_GroupGcodeRun
DFB_GroupGcodeStop
DBF_GroupMCode

### Common Instructions

High speed counter
DFB_HCnt

High speed timer
DFB_HTmr

Comparison
DFB_Compare2
DFB_CmpOutRst

Communication
DFB_ECATReset
DFB_ECATServoRead
DFB_ECATServoWrite

I/O
DFB_InputPolarity

### Package Machine

Administrative
DFB_CamRead
DFB_CamWrite
DFB_CamSyncRatio
DFB_CamCurve2
DFB_CamCurveUpdate2
DFB_CamCurveUpdateState2
DFB_RegCorrection2
DFB_Capture2

Package Machine
DFB_GearIn2
DFB_CamIn2
DFB_FlyCut2
DFB_Phasing2
DFB_Superimposed2

Horizontal Flow Wrapper
DFB_HorizontalFlowWrapper
DFB_PhaseLock_HFW
DFB_ExceptionalBagIdentify
DFB_ExceptionalBagIdentify_cap

Film Tension Control
DFB_FilmTensionControl

## 7.4 Axis

Parameter Description	Setting Value	Unit	Default	Minimum Value	Maximum Value
Axis Type Setting	A real axis which produces actual output to the drive assembly A virtual servo axis on which the operation is done in the controller	-	Virtual servo axis	-	-
Servo Axis Form Setting	Linear axis: The position value will be constantly increased (or decreased) when the linear axis rotates toward the positive direction (or negative direction). Rotary axis: The position value will be calculated again from minimum (maximum) value after the axis which rotates toward the positive direction (or negative direction) reaches the limit value.	-	Linear axis	-	-
Node Address Setting	If Real axis is selected in the Axis Type Setting box, the content in Node Address Setting must be chosen by the servo names and station addresses in ECAT Builder. It means that the axis is the set EtherCAT servo drive to which the actual output is delivered.	-	0	0	65535
Unit of Display Setting	Users can select a system unit.	-	User unit	-	-
Pulse Count Per Motor Rotation	Users can set how many pulses the controller outputs for a motor to rotate.	Pulse	10000	1	99999999
Distance Count Per Motor Rotation	Users can set the distance in an actual mechanism move whenever a motor rotates.	User Unit	10000	1	1000000
Maximum speed setting	Users can set the upper limit of the speed of the axis. (the program can be refreshed by using DFB_AxisSetting1 to input the Vmax in the contact)	User Unit/s	100000	0	2147483647
Start-up speed setting	Users can set the start-up speed for the axis to start running. (the program can be refreshed by using DFB_AxisSetting1 to input the Vbias in the contact)	User Unit/s	0	0	100000

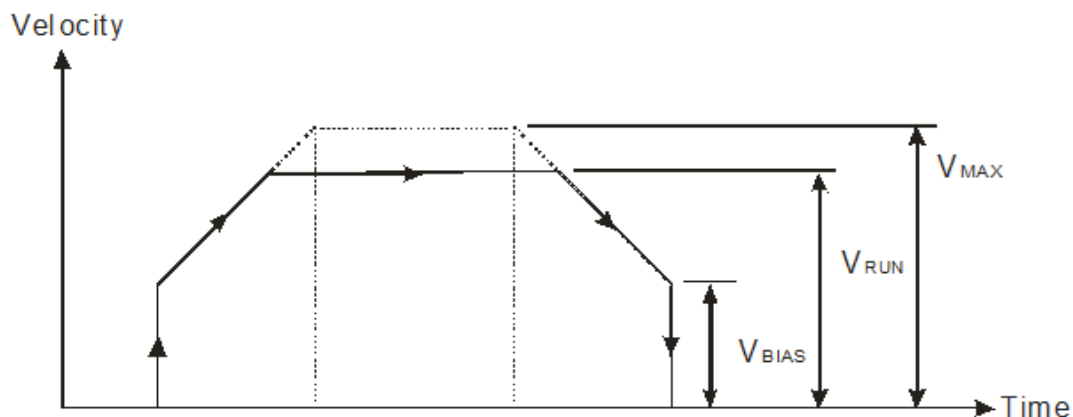

Maximum Acceleration Setting	Users can set the upper limit of the acceleration of the axis. (when the contact of the function block is set to 0, it will go maximum acceleration)	User Unit/s <sup>2</sup>	200000	0	2147483647
Maximum Deceleration Setting	Users can set the upper limit of the deceleration of the axis. (when the contact of the function block is set to 0, it will go maximum acceleration)	User Unit/s <sup>2</sup>	200000	0	2147483647
MC_Stop deceleration = 0 Setting	When the value is set to 0 in the contact of the function block MC_Stop, the methods to stop are immediate stop and deceleration stop. Immediate Stop: not sending any pulse Deceleration Stop: it will go maximum acceleration until it stops	-	Immediate Stop	-	-
Error Stop Deceleration Setting	Users can set the axis stopping method, when the axis runs beyond the software limit set. The option Immediate Stop or Deceleration Stop can be selected. Immediate Stop: not sending any pulse Deceleration Stop: it will go maximum acceleration until it stops	-	Immediate Stop	-	-
Software Limit Enable Setting	Users can set whether to enable or disable the software limit control Disabled: disable software limit function Enabled: enable software limit function (after using the software limit , users can only use the following function blocks MC_MoveAbsolute, MC_MoveRelative, MC_MoveAdditive and MC_MoveVelocity to exit from the limit position)	-	Disabled	-	-
Axis software positive limit Setting	Users can set the positive software limit value of the axis, which is only applied to the linear axis.	User Unit	2147483647	0	2147483647
Axis software negative limit Setting	Users can set the negative software limit value of the axis, which is only applied to the linear axis.	User Unit	-2147483647	-2147483647	0
Rotary Maximum Position Setting	Users can set the maximum position of the rotary axis which moves toward the positive direction. The position value will be calculated again from the minimum value after the axis reaches the limit value.	User Unit	2147483647	0	2147483647
Rotary Minimum Position Setting	Users can set the minimum position of the rotary axis which moves toward the negative direction. The position value will be calculated again from the maximum value after the axis reaches the limit value.	User Unit	-2147483647	-2147483647	0
Gear Ratio Numerator	Users can set the numerator value of the electronic gear ratio.	-	128	1	99999999
Gear Ratio Denominator	Users can set the denominator value of the electronic gear ratio.	-	1	1	99999999

7

Homing Velocity	The parameter is the speed while the homing is performed.	0.1 rpm	2000	0	2147483647
Homing Closed Velocity	While the homing is performed, the motor moves at the homing velocity at first. Then the motor starts to decelerate to this velocity and moves at this velocity when the trigger is close to the home signal.	0.1 rpm	100	0	2147483647
Permitted Deviation	The permitted deviation value for the difference between the actual position and the command position For instance: 0: when executing MC_MoveAbsolute and the actual and command positions are at 1000.00, the contact of the function block will be Done (true). -1: only the command position will be used, and the actual position will be left unchecked. Note: within the permitted deviation for the following function blocks, MC_MoveAbsolute, MC_MoveRelative, MC_MoveAdditive, DFB_GroupAbsLinear, DFB_GroupRelLinear, DFB_GroupAbsCircular, and DFB_GroupRelCircular, when the actual and command positions are the same, the contact of the function block will be Done (true).	User Unit	-1	-1	2147483647
Start single axis immediately	Enable: when triggered, it will start the single axis immediately (not affected by the scan time) Disable: after the function block is executed, the single axis will stop when all the programs are scanned by the PLC. Note: it can be used with the following function blocks MC_MoveAbsolute, MC_MoveRelative, and MC_MoveAdditive.	-	Disable	-	-
MC_CamIn direction of the master axis	Forward: if the direction of the master axis is forward, the slave will follow; while the direction of the slave axis is reverse, the slave will not move along. Not specified: the slave axis will move along with the master axis whether it's going forward or reversed.	-	Forward	-	-
The setting of the acceleration of returning to zero	Please base the setting according to each company's definition on the returning to zero unit (0x609A).	-	100	0	2147483647



## 7.5 State Transitions

This section introduces the state transitions in single axis motion and axes group motion when multiple motion control function blocks are used. The transition rules comply with the PLCopen motion control standard.

### 7.5.1 Axis States

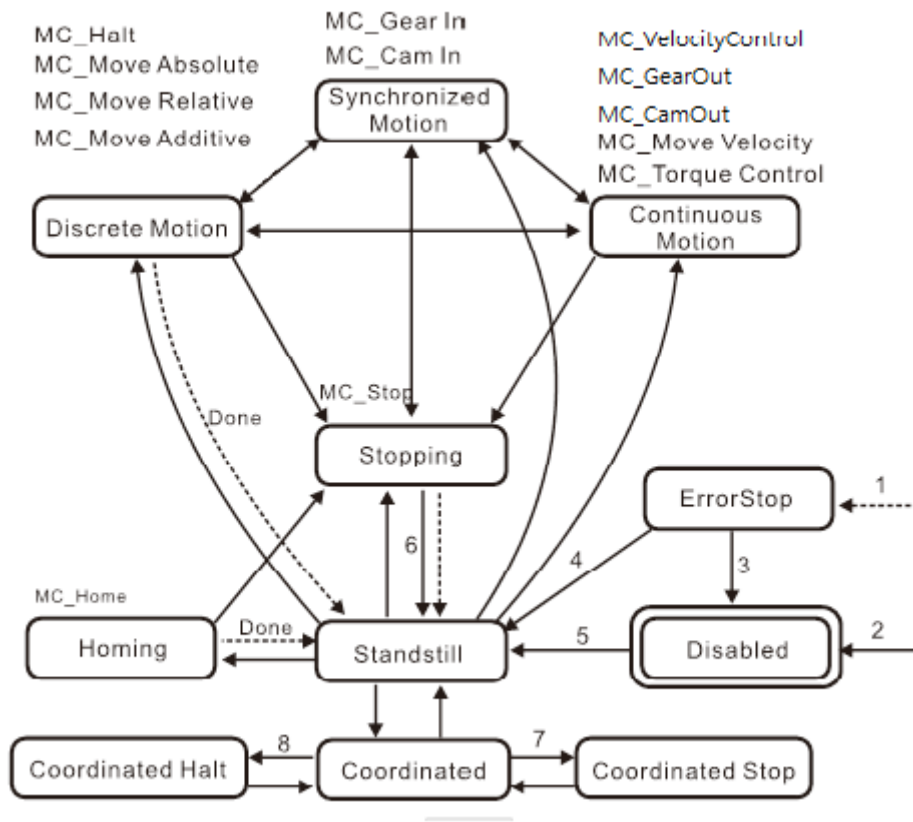

Note1: Entering “ErrorStop” state when an error occurs on the axis

Note2: *Enable* of MC\_Power changes to False and no axis error occurred.

Note3: MC\_Reset is executed and *Status* of MC\_Power is False.

Note4: MC\_Reset is executed and both *Enable* and *Status* of MC\_Power are True.

Note5: Both *Enable* and *Status* of MC\_Power change to True.

Note6: *Done* of MC\_Stop changes to True, and *Execute* of MC\_Stop. Is False.

Note7: When the axis is in “Coordinated” and *Execute* of MC\_Stop changes to True, the axis will enter “Coordinated Stop”; When the axis is in “Coordinated Stop” and *Execute* of MC\_Stop changes to False, the axis will enter “Coordinated”.

Note8: When the axis is in “Coordinated” and one single-axis motion instruction is executed on the axis, the axis group state will enter “ErrorStop” and the axis will enter “Coordinated Halt”. When the error is reset by MC\_Reset, the axis will resume “Coordinated”.

## 7.5.2 Axis Group State

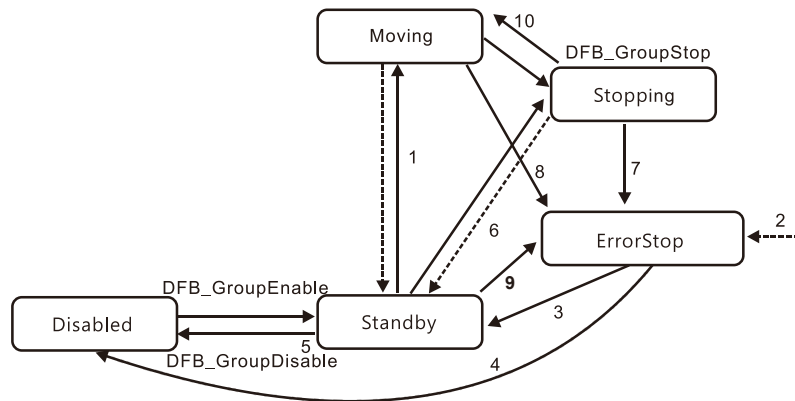

Note1: The axis group moves by multi-axis motion control instructions.

Note2: Entering “ErrorStop” state when an error occurs on the axis group.

Note3: (1) When axis group is enabled and in ErrorStop state, the DFB\_GroupReset becomes effective to switch group states. (2) When axis group executes DFB\_GroupReset in ErrorStop state and every axis of MC\_Power is Enabled (ON), the group is in “Standby” state with all errors cleared and the group maintained; (3) When executing DFB\_GroupReset in ErrorStop, the speed of every axis must be 0 to clear the axis errors; however, the contact of Busy will be ON until every axis speed in the group is 0 and all errors are cleared to reach Done.

Note4: (1) When axis group is not enabled, the DFB\_GroupReset can switch group states.

(2) When axis group executes DFB\_GroupReset in ErrorStop state and an axis of MC\_Power is not Enabled, the group state is “Disabled” with all errors cleared and the group removed.

Note5: DFB\_GroupDisable switches the group state to “Disabled.”

Note6: Group state changes to “Standby” when *Done* of DFB\_GroupStop is True and *Execute* of DFB\_GroupStop changes to False.

Note7: Group state enters to “ErrorStop” when one of the axis of MC\_Power is removed during “Stopping”.

Note8: Group state switches to “ErrorStop” when executing MC\_GroupDisable, group motion functions (MC\_GroupStop not included) or a single-axis motion instruction is executed in “Coordinated” state.

Note9: Group state switches to “ErrorStop” when a single-axis motion control instruction is executed in “Coordinated” state to remove an axis of MC\_Power in the axis group.

Note10: If ‘StopMode=1’ in DFB\_GroupStop: the execution pauses and when “Execute”=TRUE, the axis group is in “Stopping” and will change to “Moving” when “Execute”=FALSE

## 7.6 Buffer Mode

During the execution of a motion control instruction, it is possible to execute other motion instructions for the same axis. There are 6 buffer modes for users to choose from, switching from one motion instruction being executed to another motion instruction. The buffer mode can be selected through the *BufferMode* parameter of the buffered motion instruction. Users can select the buffer mode according to the buffer mode of the later instruction.

Terms used in the buffer mode are described below:

- Current motion instruction: the current motion instruction for controlling the axis
- Buffered instruction: the instruction is waiting to be executed.
- Transit velocity: the speed at which the axis moves at the moment when the currently being executed instruction is switched to the buffered instruction.
- Target velocity: the *Velocity* parameter of an instruction Target position: the *Position* or *Distance* parameter of the position-related instructions.

Buffer Mode	Description
0: mcAborting <b>(Aborting)</b>	The instruction being executed currently is aborted immediately.
1: mcBuffered <b>(Buffered)</b>	The buffered instruction just starts to control the axis after the current instruction execution is completed.
2: mcBlendingLow <b>(Blend with low)</b>	The buffered instruction just starts to control the axis after the target position of the current instruction is reached. The transit velocity is the lower of the target velocities of the current instruction and buffered instruction.
3: mcBlendingPrevious <b>(Blend with previous)</b>	The buffered instruction just starts to control the axis after the target position of the current instruction is reached. The transit velocity is the target velocity of the current instruction.
4: mcBlendingNext <b>(Blend with next)</b>	The buffered instruction just starts to control the axis after the target position of the current instruction is reached. The transit velocity is the target velocity of the buffered instruction.
5: mcBlendingHigh <b>(Blend with high)</b>	The buffered instruction just starts to control the axis after the target position of the current instruction is reached. The transit velocity is the higher of the target velocities of the current instruction and buffered instruction.

- **Demonstration: Using two MC\_MoveRelative instructions for explanation**  
 The maximum velocity of the first MC\_MoveRelative instruction is  $V_1$  and distance is  $S_1$ . The maximum velocity of the second MC\_MoveRelative instruction is  $V_2$  and distance is  $S_2$ . Modifying the value of *BufferMode* of the second MC\_MoveRelative instruction, you can get different blending processes of the two instructions. See details as below.

■ **Buffermode = mcAborting: see the four examples below.**

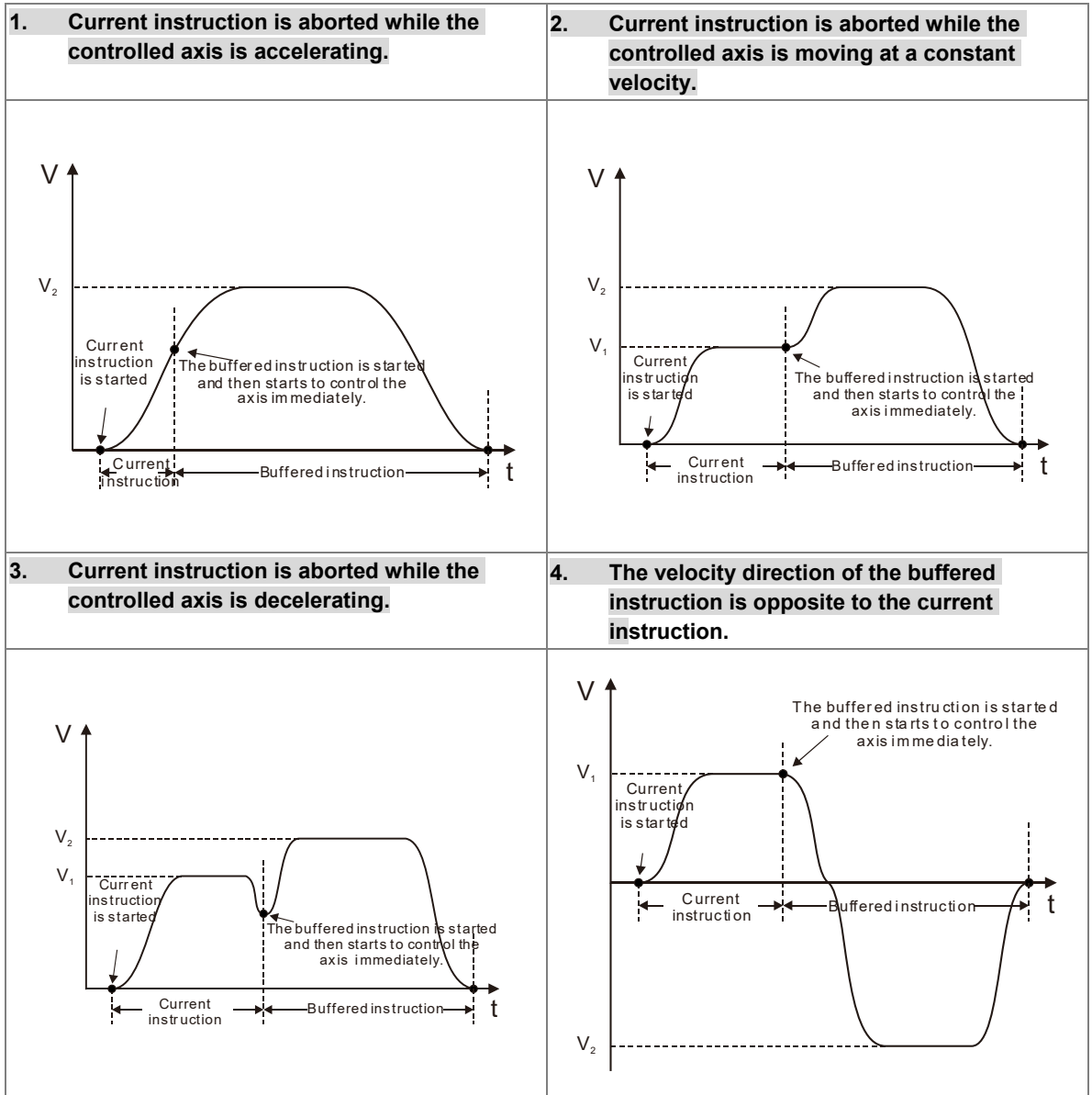

■ **Buffermode = mcBuffered:** see the two examples below.

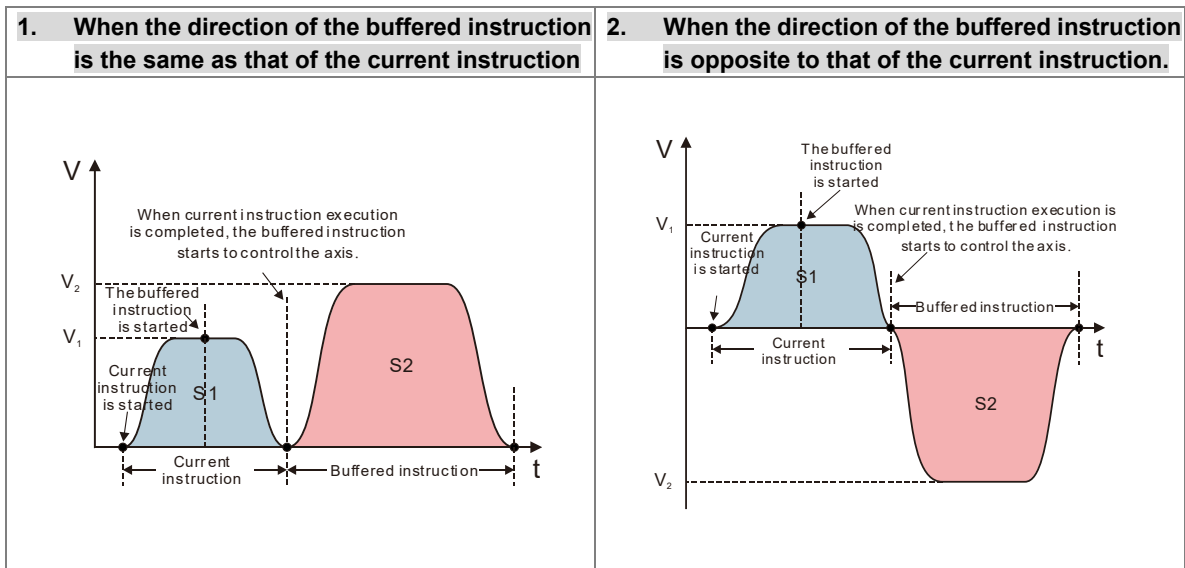

■ **Buffermode = mcBlendingLow:** see the three examples below.

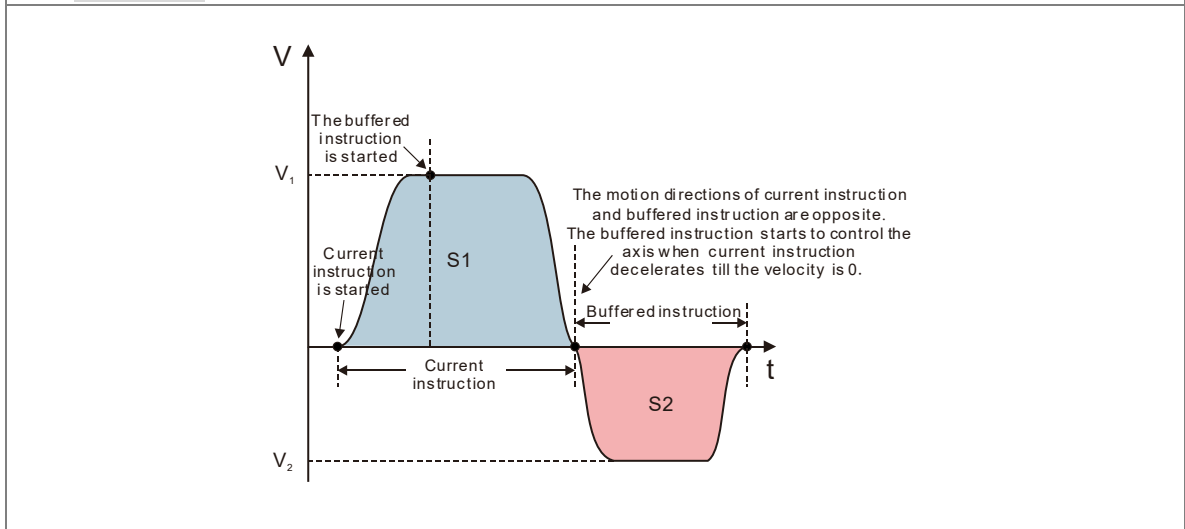
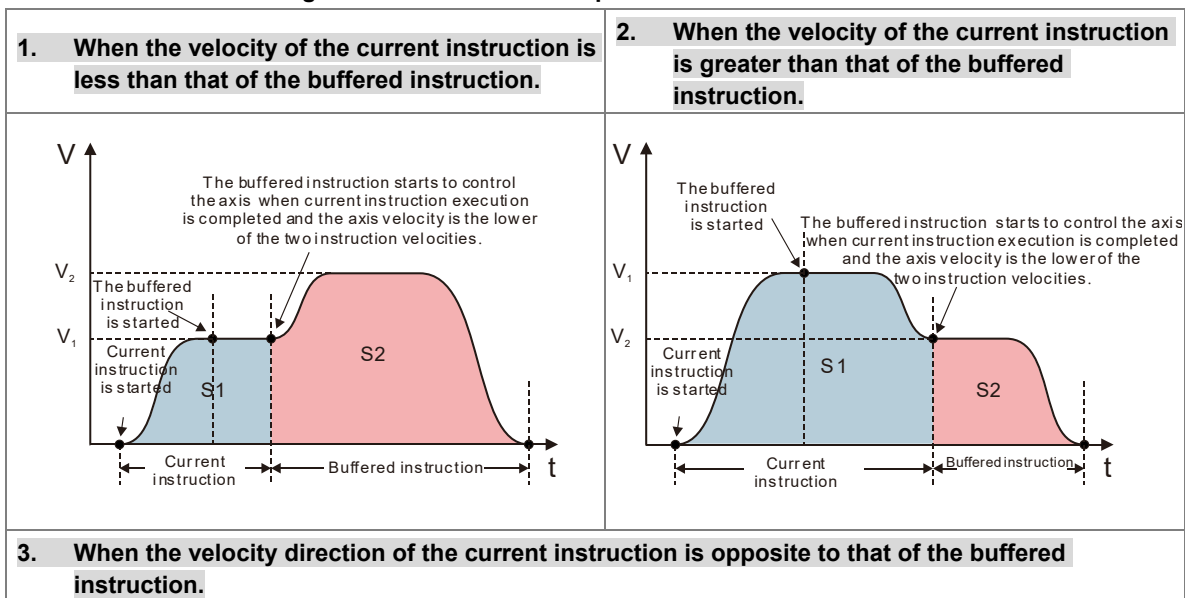

- **Buffermode = mcBlendingPrevious:** see the three examples below.

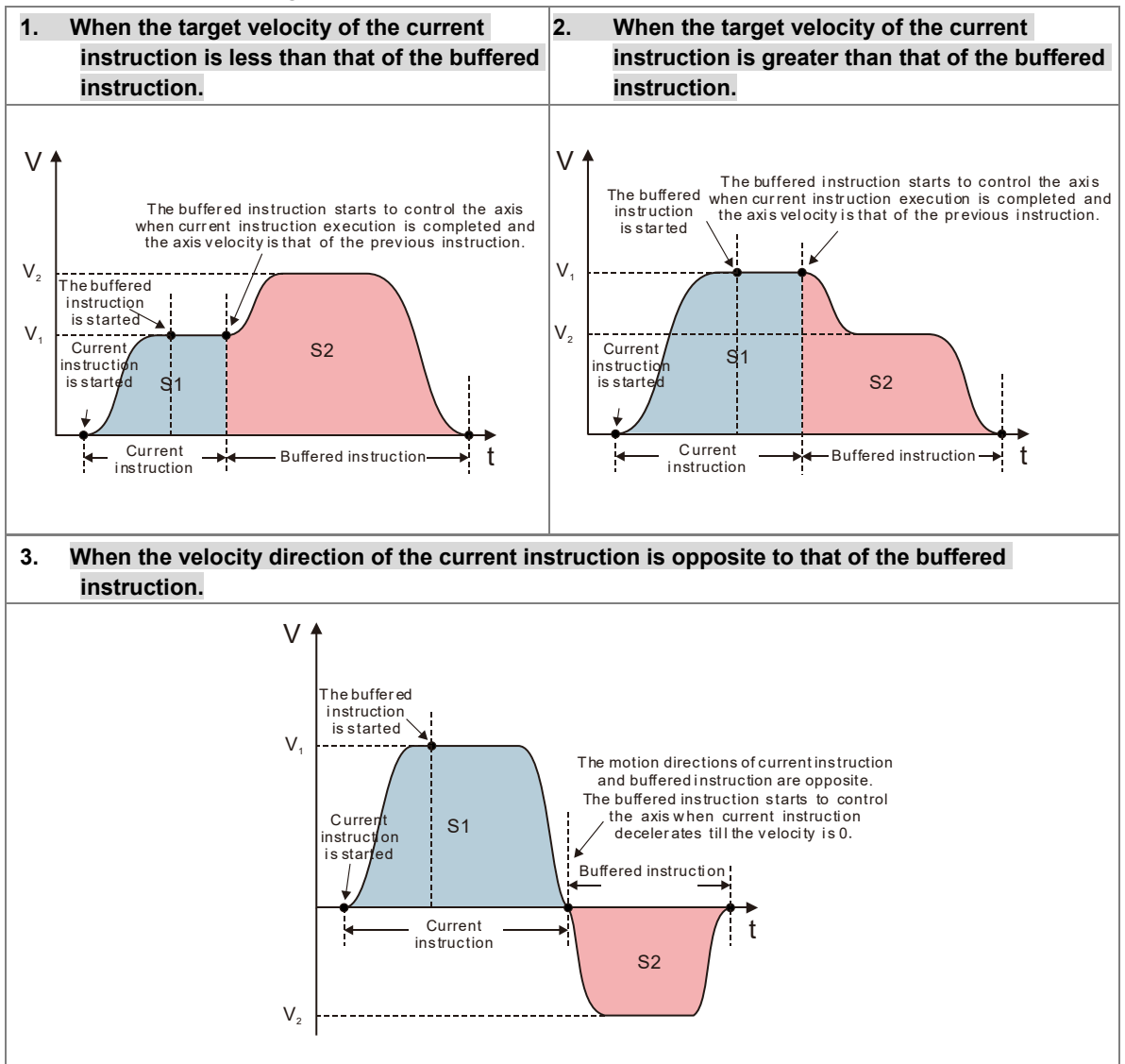

- **Buffermode = mcBlendingNext:** see the three examples below.

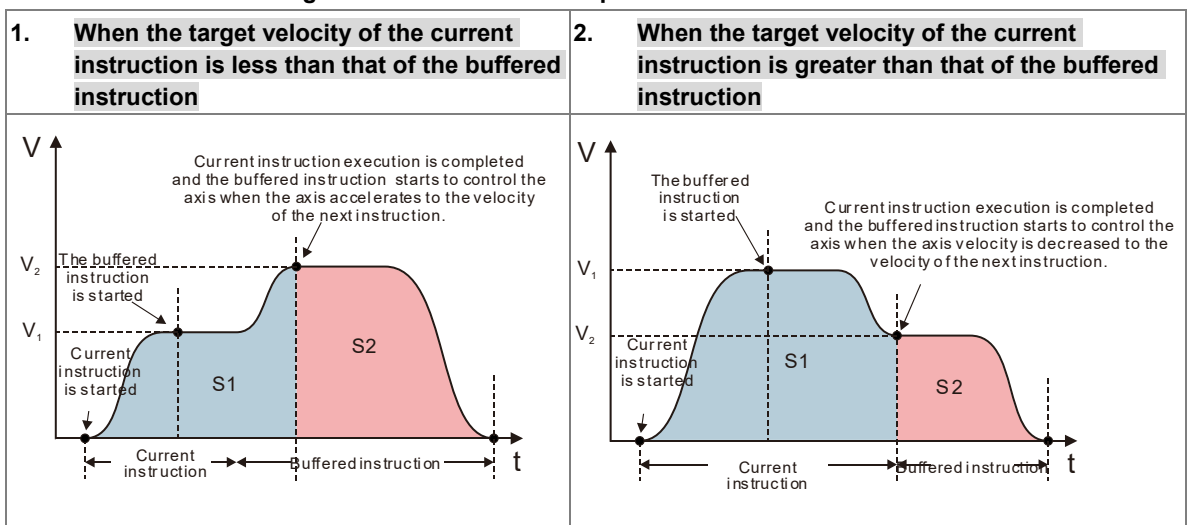

**3. When the velocity direction of the current instruction is opposite to that of the buffered instruction**

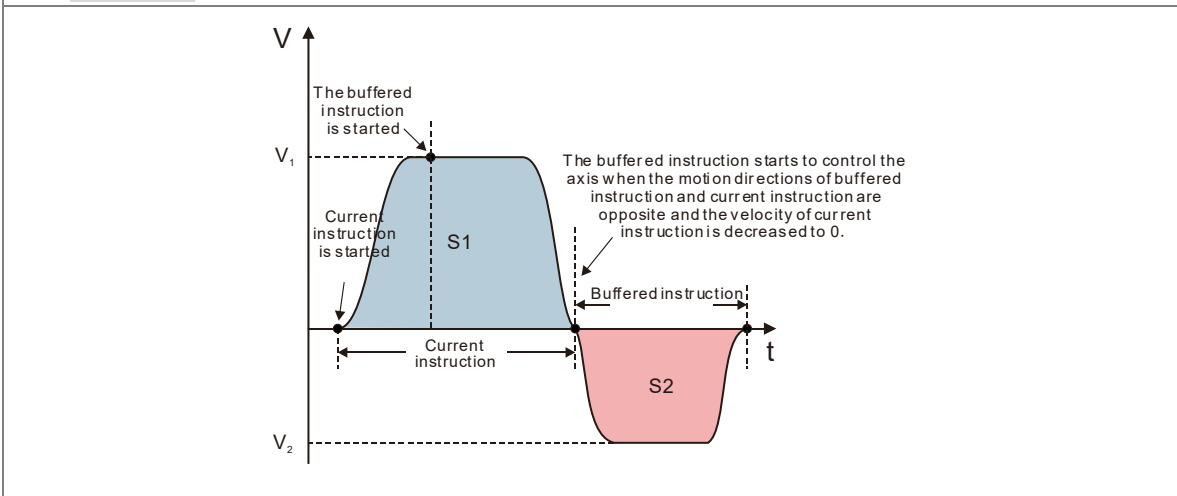

■ Buffermode = mcBlendingHigh: see the three examples below.

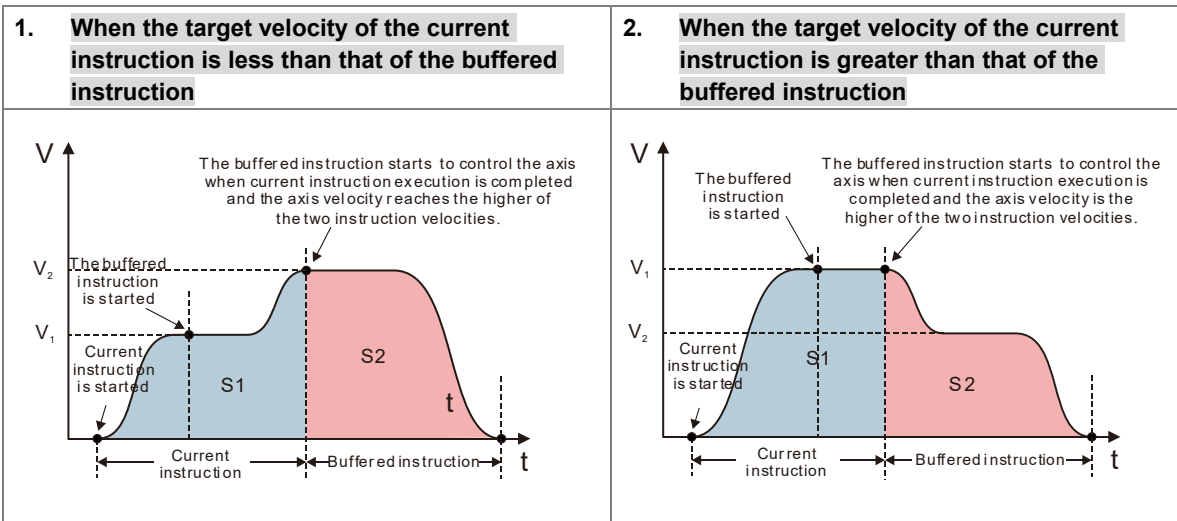

**3. When the velocity direction of the current instruction is opposite to that of the buffered instruction**

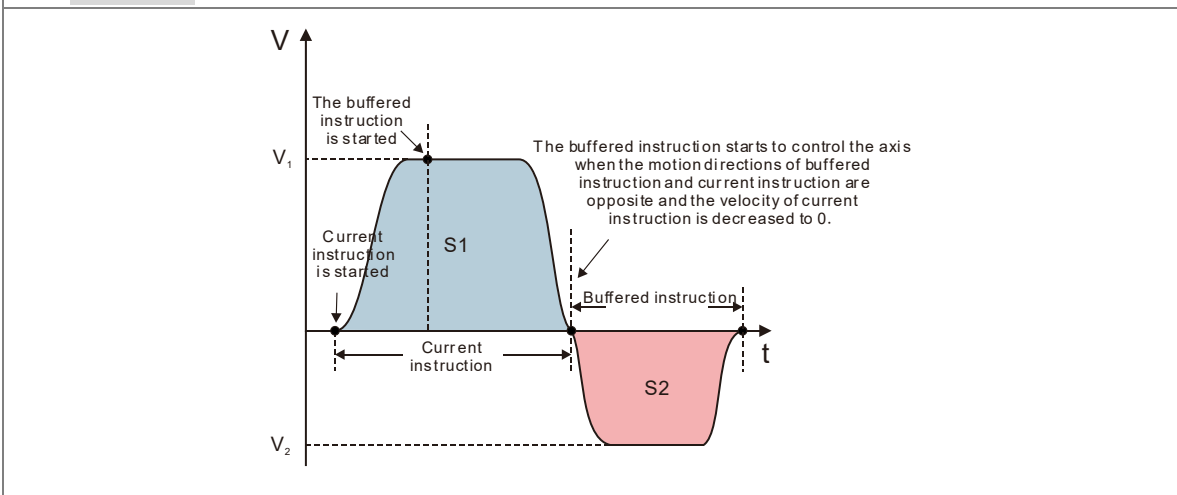

Whether the current instruction execution has been completed or not depends on the completion output parameter of the instruction. As the completion output parameter is TRUE, it indicates that the instruction execution is completed and the buffered instruction execution starts.

See the completion output parameters of instructions in the following table so as to judge the instruction execution state in a buffer mode.

Instruction name	Is it a buffered instruction? (Yes or No)	Can it be followed by a buffered instruction? (Yes or No)	Completion output parameter of an instruction
MC_MoveAbsolute	Yes	Yes	Done
MC_MoveRelative	Yes	Yes	Done
MC_MoveAdditive	Yes	Yes	Done
MC_MoveSuperImposed	No	No	—
MC_MoveVelocity	Yes	Yes	InVelocity
MC_Home	No	Yes	Done
MC_Stop	No	Yes	Done=True and Execute=False
MC_Halt	Yes	Yes	Done
MC_TorqueControl	Yes	Only for MC_TorqueControl/MC_Halt	InTorque
MC_Power	No	Yes	Status
MC_HalfSuperimposed	No	No	—
MC_CamIn	Yes	Yes	EndOfProfile
MC_GearOut	No	Yes	Done
MC_GearIn	Yes	Yes	InGear
MC_GearOut	No	Yes	Done
MC_PhasingAbsolute	Yes	Only for MC_PhasingAbsolute/ MC_PhasingRelative	Done
MC_PhasingRelative	Yes	Only for MC_PhasingAbsolute/ MC_PhasingRelative	Done
MC_VelocityControl	Yes	Only for MC_VelocityControl/MC_Halt	InVelocity

## 7.7 Execution of Function Block Instructions

The execution of the motion control instructions is controlled by the input parameters, and the status and execution results are indicated on the outputs. This section introduces the definition and function of the common interface of function block instructions.

### 7.7.1 The Interface of a Motion Control Function Block

Common inputs and outputs in motion control function blocks are listed below. A function block has one or a part of the inputs/outputs listed below. For example, a function block has either the *Execute* input or the *Enable* input, based on the properties of the motion control function block.



Inputs			
Name	Description	Date Type	Setting value (Default)
En*	Receiving the logic state in front of this instruction.	BOOL	True/False (False)
Enable	Enabling the motion control function block	BOOL	True/False (False)
Execute	Starting the motion control function block	BOOL	True/False (False)
Outputs			
Name	Description	Date Type	Setting value
Eno*	Transferring the logic state of the <i>En</i> input to the following instruction which is connected in series	BOOL	True/False (False)
Done	The execution of the function block is complete.	BOOL	True/False (False)
Valid	An output value is valid.	BOOL	True/False (False)
Busy	The motion control function block is being executed.	BOOL	True/False (False)
Active	True when the axis is being controlled.	BOOL	True/False (False)
Command Aborted(Aborted)	The execution of the motion control function block is interrupted by another instruction.	BOOL	True/False (False)
Error	An error occurs in a function block.	BOOL	True/False (False)

**\*Note:** The function of *En/Eno* is to receive or transfer the logic state in the program, and will not be included in the details of the inputs/outputs of each motion control instruction.

A motion control function block has either the *Execute* input or the *Enable* input. The *Execute/Enable* input in a motion control function block is used to start the motion control function block. A motion control function block generally has the *Busy* output and the *Done* output. The *Busy* output and the *Done* output indicate the state of the motion control function block. If the execution of motion control function block is to be interrupted by another motion control function block, the *CommandAborted/Aborted* output will be added to the motion control function block. Besides, the *Error* output is used to indicate that an error occurs when the motion control function block is executed.

A motion control function block has not only the *Execute/Enable* input, but also value/state inputs. The characteristics of the value/state inputs are described below.

**- Use of input values:**

- If the input that a motion control function block has is the *Execute* input, values are used when there is a transition in the *Execute* input's signal from low to high. If a new value is created, it becomes valid when the *Execute* input is triggered again while the instruction is not in busy status.
- If the input that a motion control function block has is the *Enable* input, values are used when there is a transition in the *Enable* input's signal from low to high. Compared with the *Execute* input, the *Enable* input is used more often when an input value is updated repeatedly.

- **An input value exceeds a range.**

After a motion control function block is started, the input values which are not in ranges allowed will be limited, or result in an error occurring in the motion control function block. If an error occurring in a motion control function block results in an error occurring in an axis, the motion control function block is applied incorrectly. You should prevent incorrect values from being generated in an applied program.

- **Outputs are mutually exclusive.**

■ If the a motion control function block has an *Execute* input which is set to True, either the *Busy* output, the *Done* output, the *CommandAborted /Aborted* output, or the *Error* output can be set to True.

■ If the a motion control function block has an *Enable* input, the *Valid* output and the *Error* output are mutually exclusive, and only the *Valid* output or the *Error* output can be set to True.

- **Time when output data/states are valid**

■ If the input that a motion control function block has is the *Execute* input, the *Done* output, the *Error* output, the *CommandAborted* output, and data output are reset when there is a transition in the *Execute* input's signal from high to low, but the execution of the function block does not stop when there is a transition in the *Execute* input's signal from high to low. Even if the *Execute* input in a motion control function block is reset before the execution of the motion control function block is complete, output states will still be generated and retained for one cycle. If a motion control function block is started again before the execution of the motion control function block is complete, the motion control function block will not give feedback to the *Done* output and the *CommandAborted* output, and an error will occur.

■ If the input that a motion control function block has is the *Enable* input, the *Valid* output, the *Busy* output, and the *Error* output are reset when there is a transition in the *Enable* input's signal from high to low. (MC\_Power has different behaviors on the inputs and outputs, refer to MC\_Power for details.)

- **Characteristic of the *Done* output**

The *Done* output in a motion control function block will be set to True after the motion control function block is executed successfully.

- **Characteristic of the *Busy* output**

■ If the input that a motion control function block has is the *Execute* input, the motion control function block uses the *Busy* output to indicate that the execution of the motion control function block is not complete, and new output states (values) are expected to be generated. The *Busy* output is set to True when there is a transition in the *Execute* input's signal from low to high. When the *Done* output, the *CommandAborted* output, and the *Error* output are set to True, the *Busy* output are reset.

■ If the input that a motion control function block has is the *Enable* input, the motion control function block uses the *Busy* output to indicate that the execution of the motion control function block is not complete, and new output states (values) are expected to be generated. The *Busy* output in a motion control function block is set to True when there is a transition in the *Enable* input's signal from low to high, and is set to True when the motion control function block is executed. When the *Busy* output is set to True, output states (values) still change.

- **Characteristic of the *CommandAborted* output**

The *CommandAborted* output in a motion control function block is set to True when the execution of the motion control function block is interrupted by a command.

- **Relation between the *Enable* input and the *Valid* output**

If the input that a motion control function block has is the *Enable* input, the motion control function block uses the *Valid* output to indicate whether output data/states are valid. The *Valid* output is set to True only when the *Enable* input is set to true and output data/state are valid. If an error occurs in a motion control function block, output data/states will

not be valid, and the *Valid* output will be set to False. The *Valid* output in a motion control function block will not be True until the error occurring in the motion control function block is eliminated, and output data/states become valid.

### 7.7.2 Timing Diagram for Input/Outputs

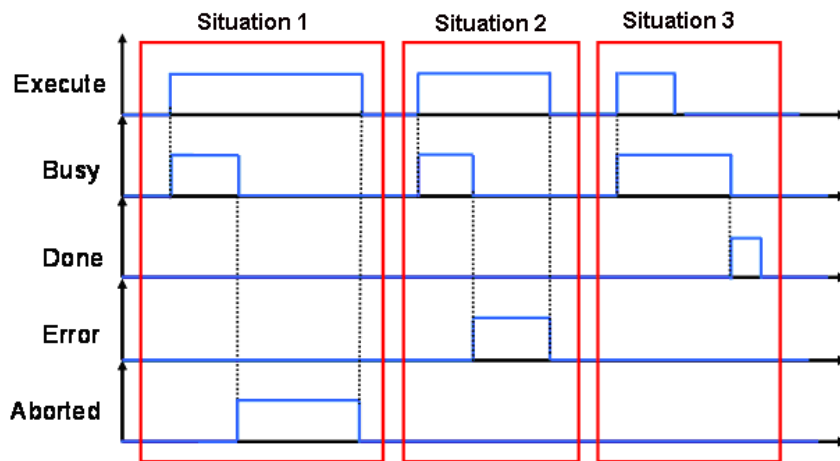

Situation 1: The execution of the motion control function block is interrupted.

Situation 2: An error occurs in the motion control function block.

Situation 3: The execution of the motion control function block is complete normally.

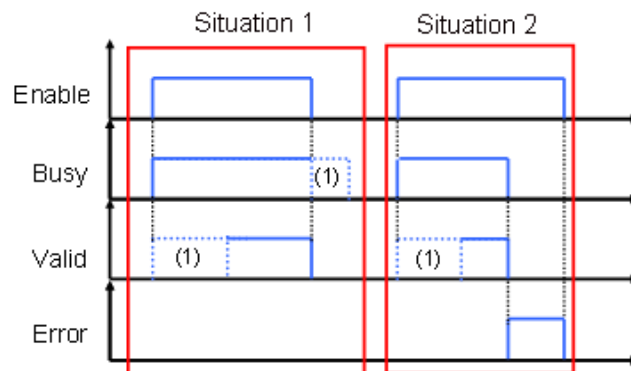

(1) It may take some time.

Situation 1: The motion control function block is executed normally.

Situation 2: An error occurs in the motion control function block.

## 7.8 Positions

This section describes the positions that are used in motion control programming.

### 7.8.1 Position Types

Position Type	Description
Command position	The command position is the position value that the Motion CPU outputs to drive an axis.
Actual position	The actual position is the position feedback value from the servo drive or the encoder.

The valid positions for each axis type are listed as below.

### 7.8.2 Applicable Positions for Each Axis Type

Axis type	Position Type	
	Command Position	Actual Position
Servo axis	Valid	Valid
Virtual axis	Valid	Valid*

\*Note: the command position and the actual position is the same on virtual axis.

## 7.9 Electronic Cam

This section introduces the operation of electronic cam (e-cam), and the steps to applied e-cam by settings in the software and the motion control instructions related to e-cam. For details about each mentioned instruction, please refer to **AH Motion Controller – Motion Control Instructions Manual**.

### 7.9.1 Introduction of Electronic Cams

A traditional mechanical cam is composed of a cam, a follower, and a support.

1. A mechanical cam is a rotating sliding piece with irregular shape. In general, it is an input object which rotates at a uniform speed. It makes a follower move regularly by coming into contact with the follower.
2. A follower is a part driven by a mechanical cam. In general, it is an output object which generates motion which is not uniform, sequental, and regular motion.
3. A support is a piece that which is used to support a mechanical cam and a follower.

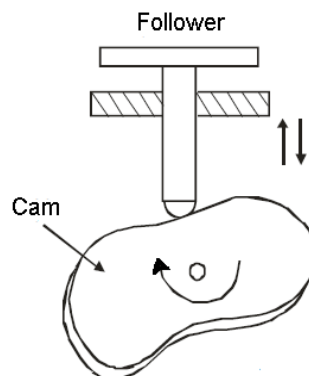

Compared with a traditional cam, an electronic cam has the following advantages.

1. Friendlier user interface
2. Different products require different cam curves. Users can modify the electronic cam data in an electronic cam in software. Users do not need to modify the mechanical design.
3. High acceleration
4. Smoother operation

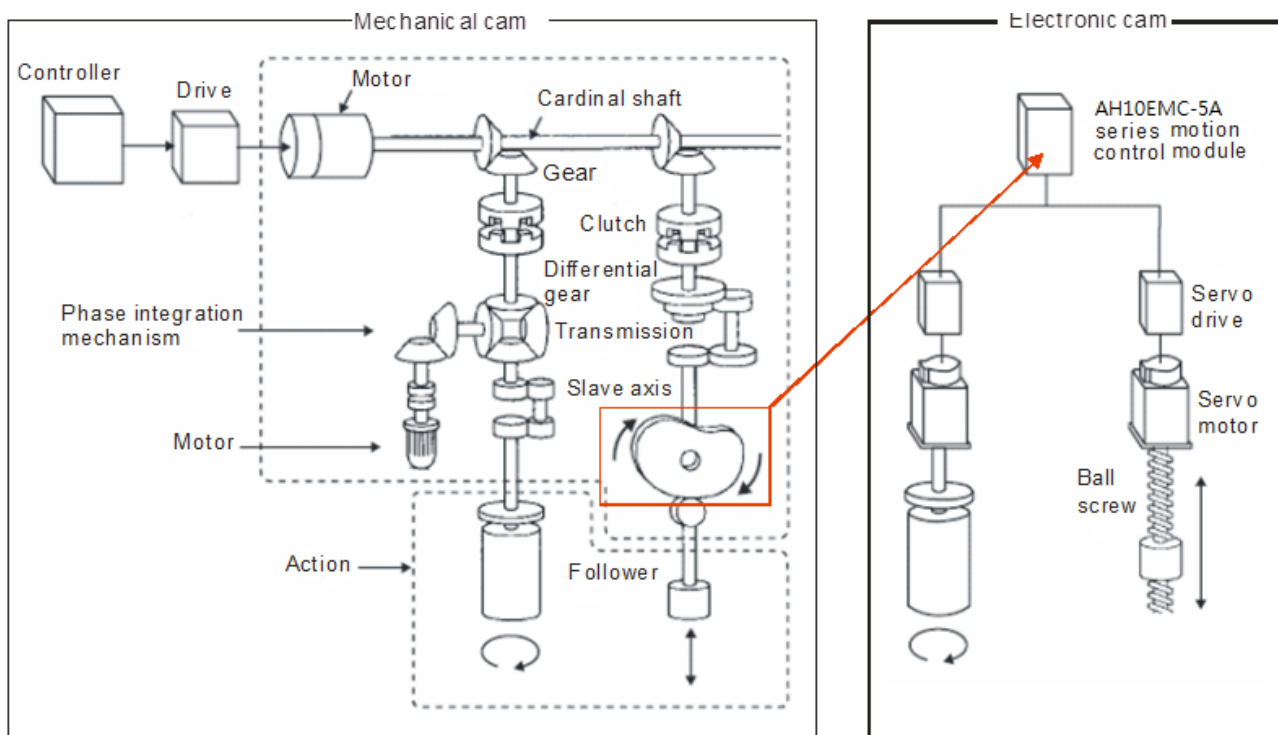

### 7.9.2 Operation of an Electronic Cam

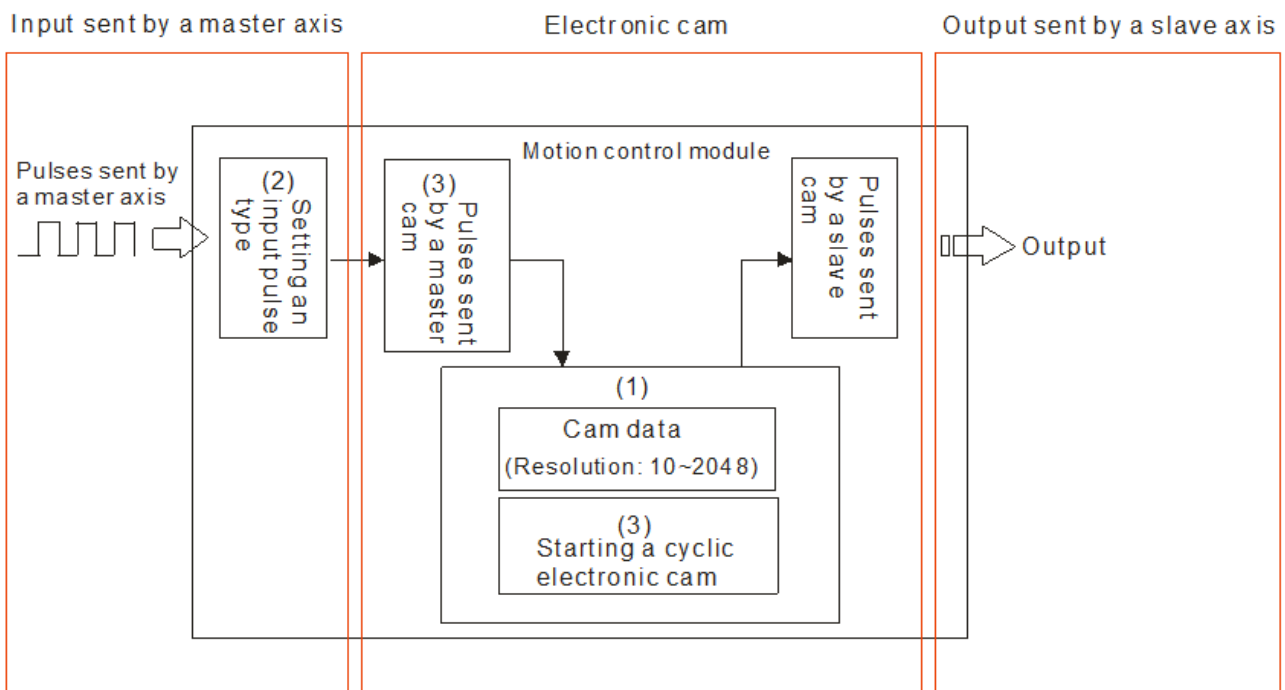

Step 1	Step 2	Step 3
Initial setting	Setting a master axis and a slave axis	Starting/Stopping an electronic cam
Creating electronic cam data (1) Setting an input pulse type (2)	Setting a master axis (3) Setting the starting angle of the master axis specified (3) Setting a slave axis (3)	Starting/Stopping a cam which operates cyclically (3)

### 7.9.2.1 Initial Setting

#### ■ Creating Electronic Cam Data

There are two methods of creating electronic cam data.

Method 1: Function that relates the positions of a master axis to the positions of a slave axis

Method 2: Measuring the relation between the positions of a master axis and the positions of a slave axis at work

Please refer to section 7.7.3 for more information.

#### ■ Setting an Input/Output Pulse Type

##### 1. Setting an input pulse type

The master axis specified can be a manual pulse generator, a motion axis, AC0, AC4, AC8, AC12, AC16, or AC20. If you use a counter as a master axis, you have to set an input pulse type. You can set an input pulse type for the counter used by means of the motion control function block DFB\_HCnt.

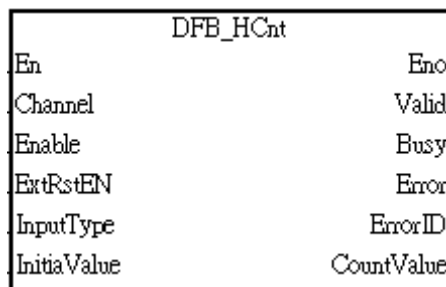

##### 2. Value of InputType

Input value	Input type (positive logic)	Description
mcUD (0)		Counting up/down
mcPD (1)		Pulses+Directions
mcAB (2)		A/B-phase pulses

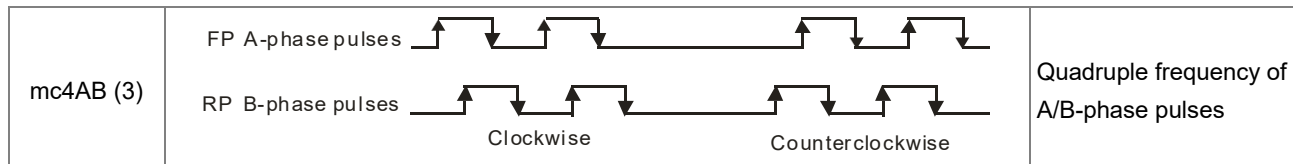

### 7.9.2.2 Setting a Master/Slave Axis and Operating an Electronic Cam

You can set a master axis and a slave axis, and operate an electronic cam by MC\_CamIn.

After the setting of the inputs in the motion control function block MC\_CamIn is complete, the instruction will be enabled if *Enable* is set to True. The outputs in the motion function block MC\_CamIn can be used to monitor the electronic cam motion.

MC_CamIn	
En	Eno
Master	InSync
Slave	EndOfProfile
Execute	Busy
ContinuousUpdate	Active
CamTable	CommandAborted
Periodic	Error
MasterAbsolute	ErrorID
SlaveAbsolute	
MasterOffset	
SlaveOffset	
MasterScaling	
SlaveScaling	
MasterStartDistance	
MasterSyncPosition	
ActivationPosition	
ActivationMode	
StartMode	
Velocity	
Acceleration	
Deceleration	
Jerk	
MasterValueSource	
BufferMode	

### ■ Setting a Master Axis

You can set a master axis by *Master* in the motion control function block MC\_CamIn.

MC_CamIn	
En	Eno
Master	InSync
Slave	EndOfProfile
Execute	Busy
ContinuousUpdate	Active
CamTable	CommandAborted
Periodic	Error
MasterAbsolute	ErrorID
SlaveAbsolute	
MasterOffset	
SlaveOffset	
MasterScaling	
SlaveScaling	
MasterStartDistance	
MasterSyncPosition	
ActivationPosition	
ActivationMode	
StartMode	
Velocity	
Acceleration	
Deceleration	
Jerk	
MasterValueSource	
BufferMode	

Value of the Master

Input value	Definition	Description
1~n	Motion axis	A motion axis 1~n is used as a master axis (AH08EMC: n=8 , AH10EMC: n=16, AH20EMC: n=32)
200	Counter	The counter AC00 is used as a master axis.
204	Counter	The counter AC04 is used as a master axis.
208	Counter	The counter AC08 is used as a master axis.
212	Counter	The counter AC12 is used as a master axis.
216	Counter	The counter AC16 is used as a master axis.
220	Counter	The counter AC20 is used as a master axis.



■ **Setting the Starting Engaging Position of a Master Axis**

You can set the starting engaging position of the master axis specified by *ActivationPosition* in the motion control function block MC\_CamIn.

MC_CamIn	
En	Eno
Master	InSync
Slave	EndOfProfile
Execute	Busy
ContinuousUpdate	Active
CamTable	CommandAborted
Periodic	Error
MasterAbsolute	ErrorID
SlaveAbsolute	
MasterOffset	
SlaveOffset	
MasterScaling	
SlaveScaling	
MasterStartDistance	
MasterSyncPosition	
ActivationPosition	
ActivationMode	
StartMode	
Velocity	
Acceleration	
Deceleration	
Jerk	
MasterValueSource	
BufferMode	

Value of the *ActivationPosition*

Input value	Definition	Description
Negative number, positive number and 0	starting engaging position of the master axis specified	Specify the position of the master axis as the engagement begins. In other words, when the master axis passes the position, the slave axis starts to perform the engagement action.

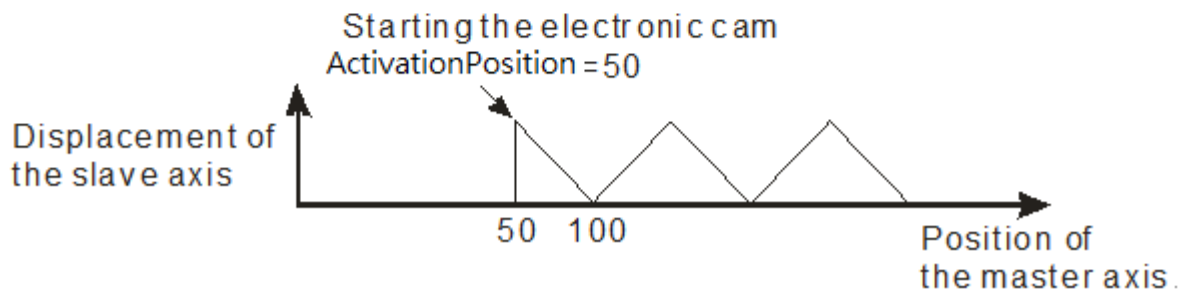
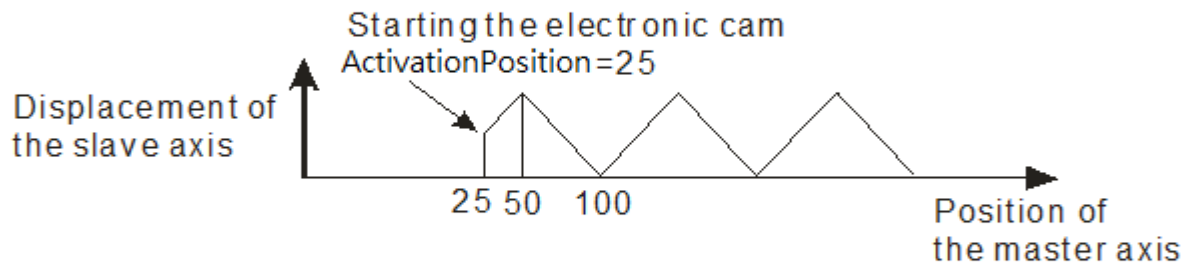
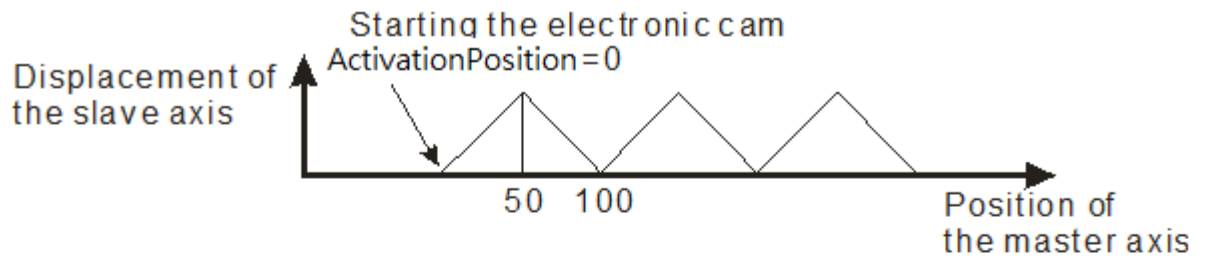

■ **Setting a Slave Axis**

You can set a slave axis by *Slave* in the motion control function block MC\_CamIn.

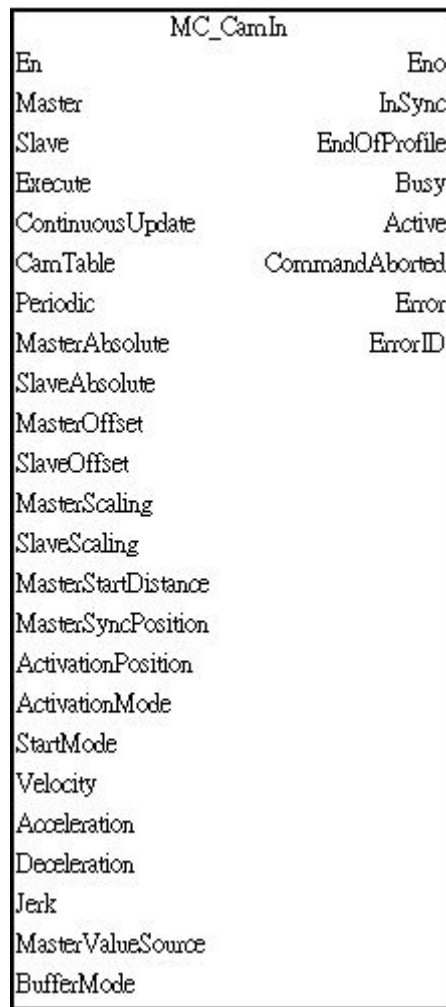

Value of *Slave*

Input value (Default value)	Definition	Description
K1~Kn* (0)	Motion axis number	The motion axis that is used as a slave axis.

\*Note: Kn refers to the maximum supported axes of different models. For example, AH20EMC-5A supports K1~K32.

**7**

**7.9.2.3 Starting/Stopping an Electronic Cam Operating Cyclically**

If an electronic cam operates cyclically, the slave axis of the electronic cam moves in accordance with electronic cam data when the master axis of the electronic cam moves. Electronic cam data defines only one cycle. The relation between the positions of a master axis and the positions of a slave axis is the repeated extension of electronic cam data.

Electronic cam data

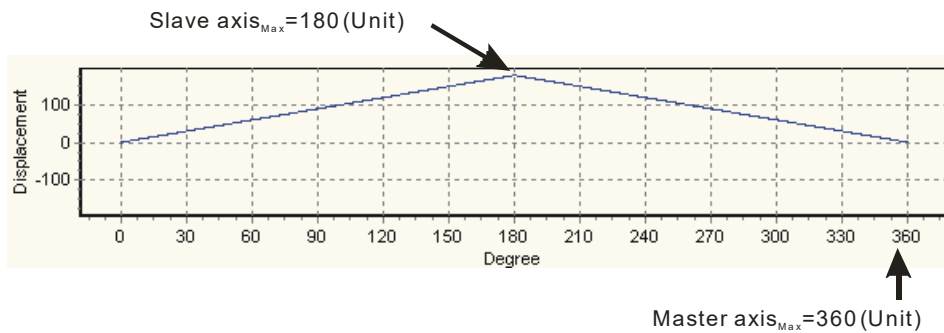

### ■ Starting a Cyclic Electronic Cam Operation

After you set a master axis, a slave axis, and a starting angle by means of inputs in the motion control function block MC\_CamIn, electronic cam motion will be started if the *Enable* is set to True and the *Periodic* is set to True.

MC_CamIn	
En	Eno
Master	InSync
Slave	EndOfProfile
Execute	Busy
ContinuousUpdate	Active
CamTable	CommandAborted
Periodic	Error
MasterAbsolute	ErrorID
SlaveAbsolute	
MasterOffset	
SlaveOffset	
MasterScaling	
SlaveScaling	
MasterStartDistance	
MasterSyncPosition	
ActivationPosition	
ActivationMode	
StartMode	
Velocity	
Acceleration	
Deceleration	
Jerk	
MasterValueSource	
BufferMode	

Value of the *EndofProfile*

Output value	Definition	Description
True/False	Starting a cam cycle	Indicates the end point of the cam profile is completed. (Resets automatically)

The steps of starting an electronic cam which operates cyclically are as follows.

- At the time T1, *Enable* is set to True (an electronic cam which operates cyclically is started).
- After the time T2 elapses, *EndofProfile* will be set to True. *EndofProfile* will be reset after one scan cycle.
- During the time T3, the initialization of the electronic cam is complete, the electronic cam operates cyclically, and the motion of the slave axis specified follows the motion of the master axis specified in accordance with the electronic cam data created.

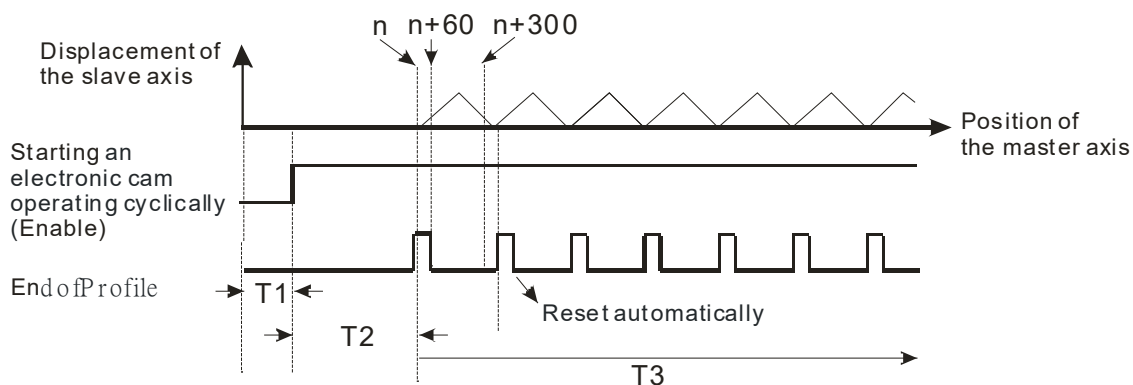

### ■ Stopping a Cyclic Electronic Cam Operation

You can stop an electronic cam by *CamOut* in the motion control function block MC\_CamIn.

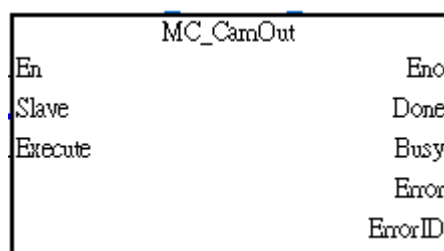

#### 1. Value of *Execute*

Input value	Definition	Description
True/False	Not engaging with the master axis specified	If <i>CamOut</i> is set to True, the slave axis specified will not engage with the master axis specified.

#### 2. Value of *Done*

Output value	Definition	Description
True/False	Disable the slave axis specified engaging with the master axis specified.	If the engagement of the slave axis specified and the master axis specified is done, the output pin will be set to True.

### 7.9.3 Creating Electronic Cam Data

Electronic cam data defines the relation between the positions of a master axis and the positions of a slave axis.

Before you create a cam chart in ISPSOft, you have to know the relation between the positions of a master axis and the position a slave axis. There are two methods of getting the relation between the positions of a master axis and the positions of a slave axis.

- Method 1: Creating master/slave relation by setting E-CAM data
- Method 2: Importing the recorded E-CAM data with master/slave relation to create the E-CAM curves

After electronic cam data defines the relation between the master/slave positions, you can get the positions of the slave axis by means of the positions of the master axis.

#### 7.9.3.1 Creating a CAM Chart in ISPSOft

##### Creating master/slave relation by setting E-CAM data

After you create a project in ISPSOft, right-click **E-CAM Editor** in the system information area, and click **NEW**, the **New E-CAM-Chart** window will appear. Set the parameters in the **New E-CAM-Chart** window, and then click **OK**. An E-CAM data item under **E-CAM Editor** will appear in the system information area. The below steps are the procedures for setting up parameters for the new E-CAM chart.

- ① Type an E-CAM name in the **Name** box.
- ② Type an E-CAM ID in the **Item ID** box. E-CAM ID ranges from 1 to 32.
- ③ If you want to set an E-CAM password, you have to type the same password in the two boxes. You can only type English letters, numerical digits. When the E-CAM is opened next time, the password will be requested.
- ④ If **Show Charact** checkbox is selected, the input characters for the password will be displayed.

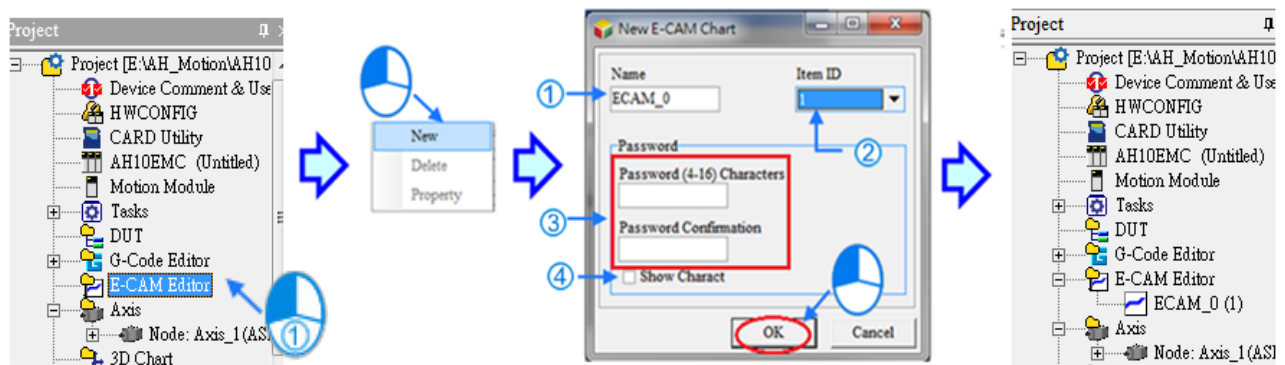

After the parameters are set, click OK and the E-CAM editing window will be displayed as below.

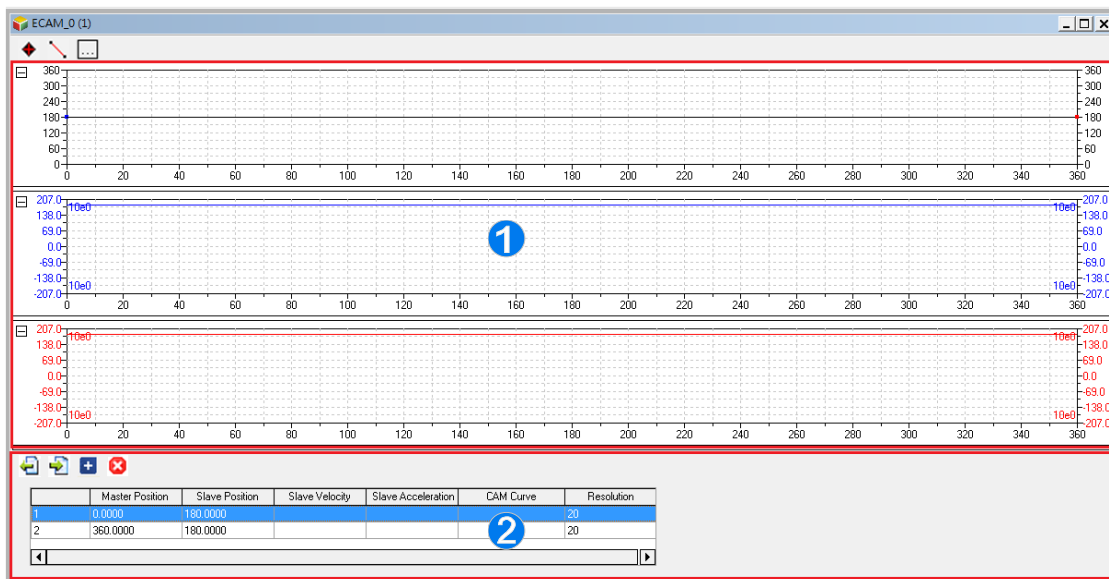





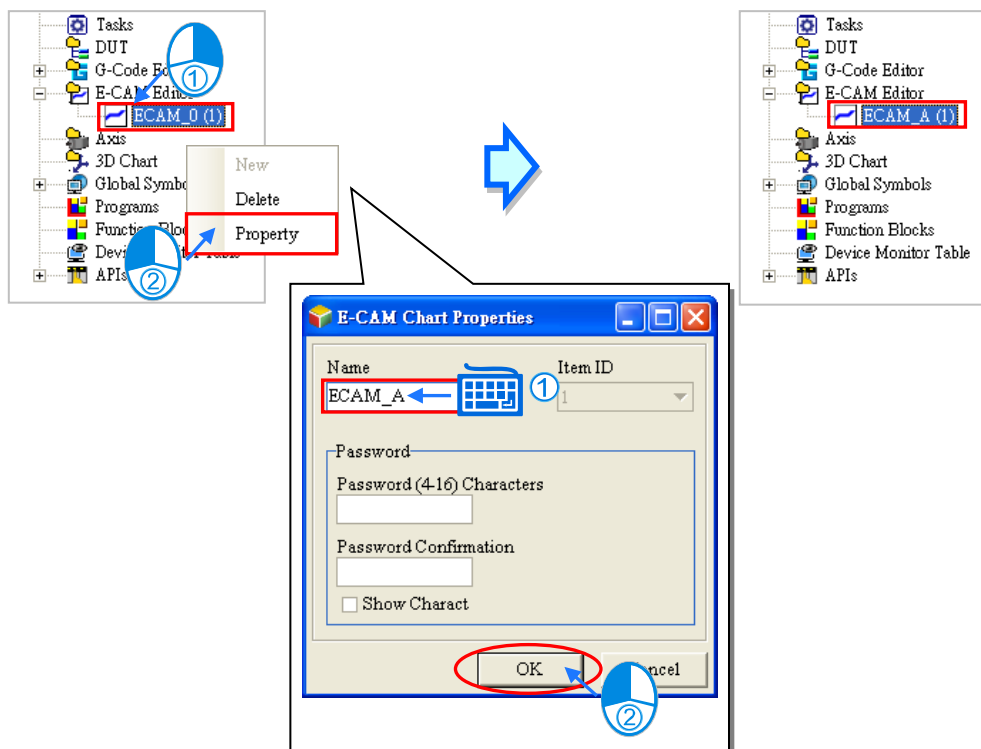

① E-CAM curve area: the E-CAM curves of position, velocity and acceleration are established according to the specified data in the Data setting area. You can modify the curves by moving the data points directly in the E-CAM chart, or insert data points or sections by using function buttons.

② Data setting area: By using function buttons, you can create or delete data points or sections and modify the curves by specifying the data points in the Data setting area. The changes in the data settings area will be synchronized to the E-CAM curve area.

After the E-CAM item is created, you can right-click on the item and select Delete to delete this item, or select Property to change the name and password of this E-CAM item. Note that Item ID is not allowed to be changed. Refer to the diagram below.



**Function buttons for E-CAM chart:**

Icon	Name	Description
	Insert a point	Inserting an data point to the position curve in the E-CAM curve area
	Insert a section	Inserting a section with two end points into the position curve in the E-CAM curve area
	E-CAM setting	Opening the E-CAM setting window
	Export	Exporting the E-CAM data in .txt format and specifying the directory for saving this file.
	Import	Importing the E-CAM file from the specified directory
	Insert a row	Inserting a row under the selected row in the Data setting area
	Delete a row	Deleting a selected row in the Data setting area.

The operation and setting steps by using the function buttons are explained as below.

You can click  (Insert a point) and move the cursor to the position where you want to create a data point. Click at the position to create the data point, and the position/velocity/acceleration data of the data point will also be inserted in the Data setting area as below.



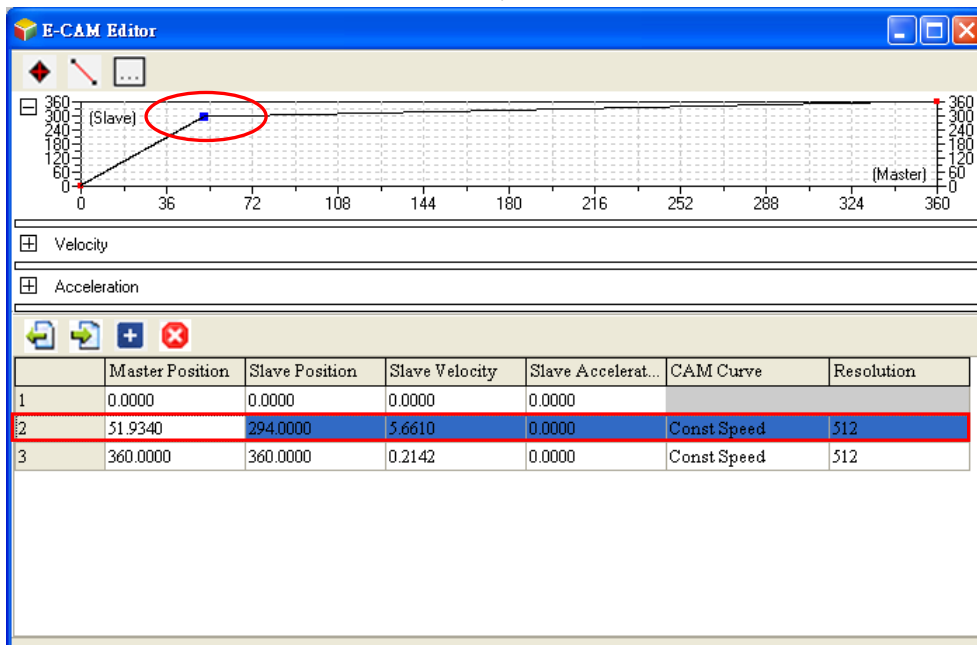
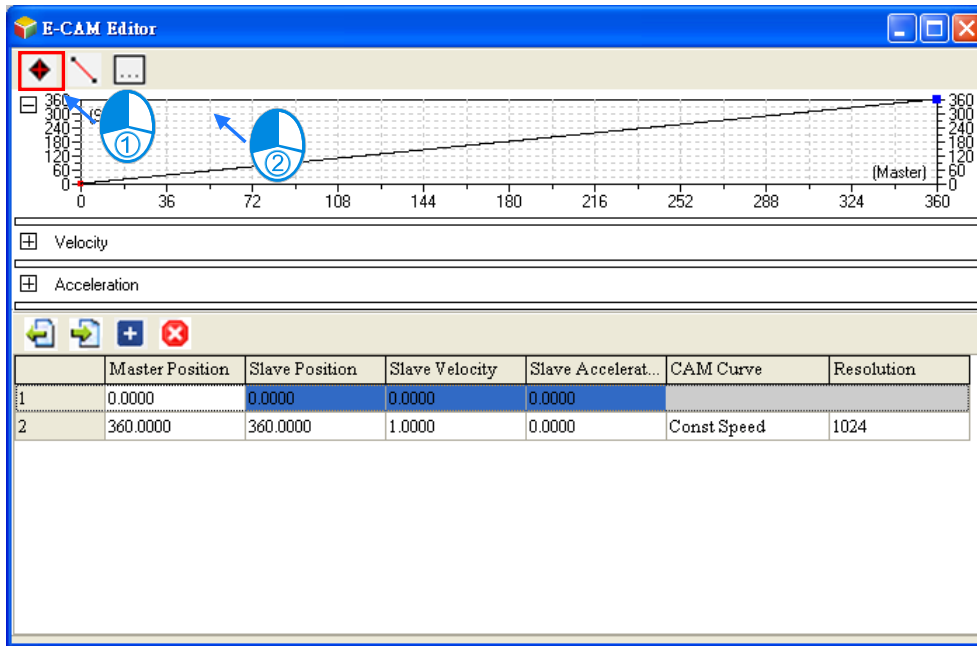

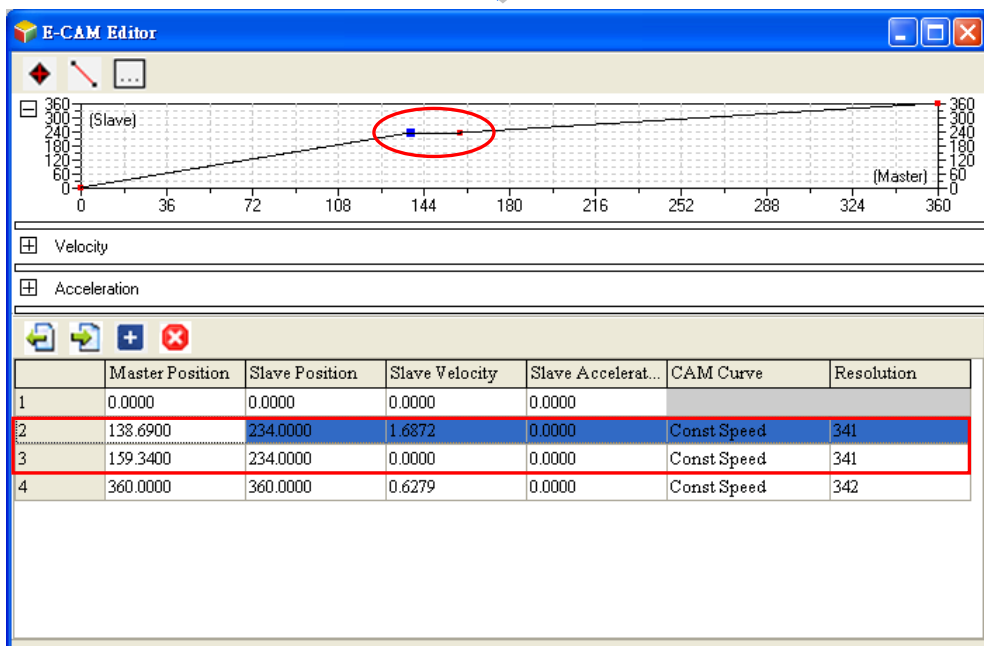
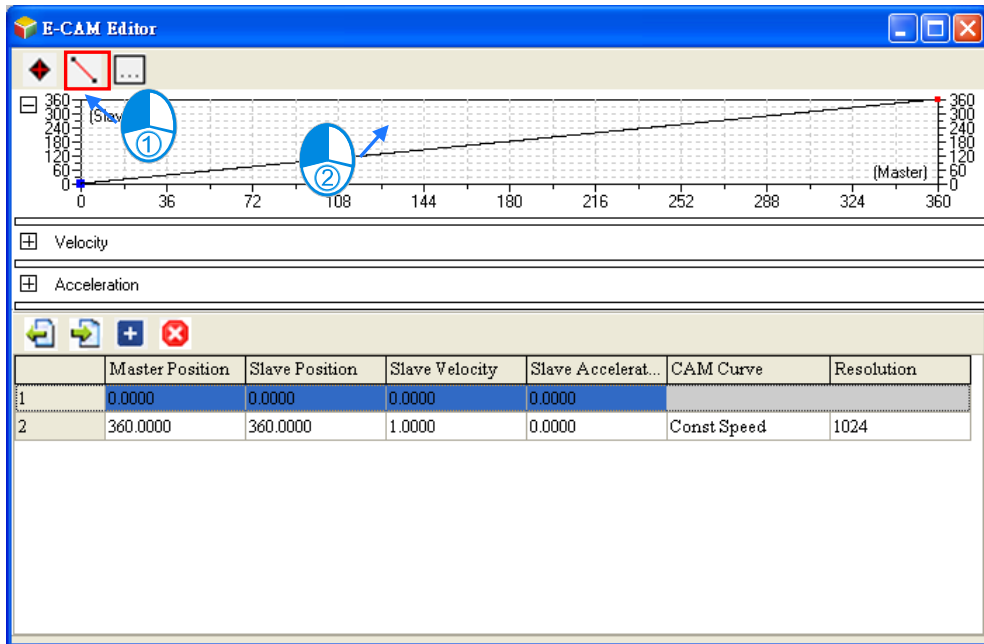

- You can click  (Insert a section) and move the cursor to the position where you want to insert a section. Click at the data point to create the section, and the position/velocity/acceleration data of the two end points of the section will also be inserted in the Data setting area as below.

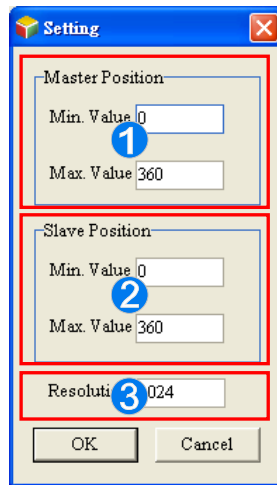

2. Click  (Setting) to open the setting window for the current E-CAM chart.



- ❶ Master position: defines the display range of the master axis in the E-CAM curve area.
- ❷ Slave position: defines the display range of the slave axis in the E-CAM curve area.
- ❸ Resolution: defines the resolution of this E-CAM chart (max.: 2047)

3. You can click  (Insert a row) or  (delete a row) to edit the Data setting area. Modifying the master/slave position in the table will change the E-CAM curve in the E-CAM curve area immediately.

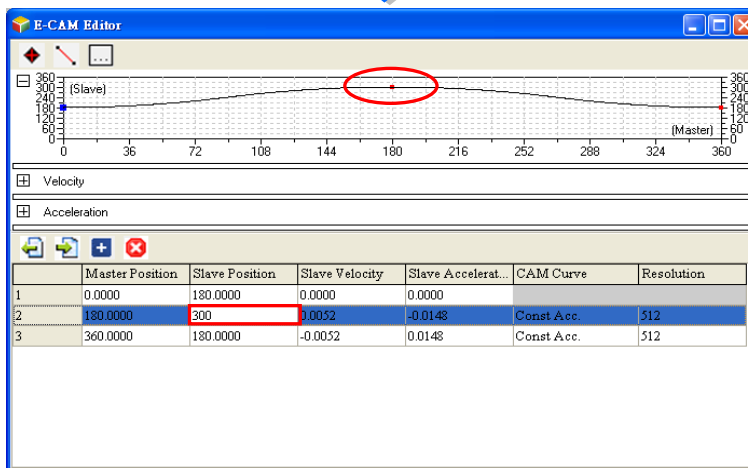
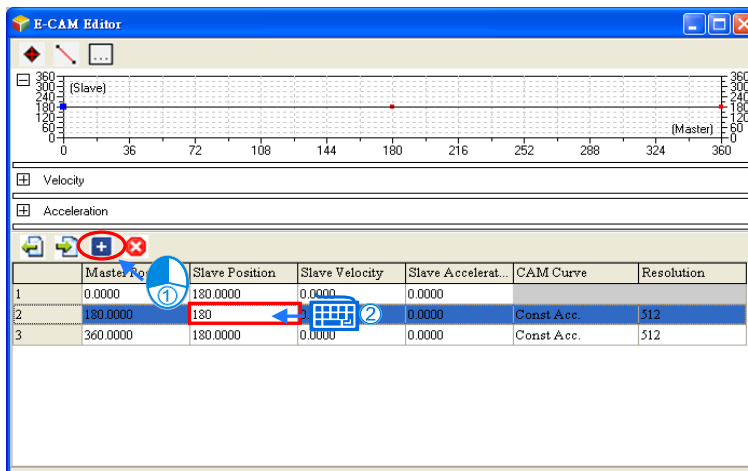

In the Data setting area, each column in the table can be specified to define the parameters of the data points which are listed in rows. The whole E-CAM curve are constructed by these data points (max. 20 rows), and the E-CAM cycle will operate according to the designed E-CAM curves. The columns in the Data setting area are explained as below.

- Master position: the master position of the data point
- Slave position: the slave position of the data point
- Slave velocity: the slave velocity calculated automatically according to the specified position.
- Slave acceleration: the slave acceleration calculated automatically according to the specified position.
- CAM Curve: the cam curve type between the data points, including Const Speed, Const Acc., Single Hypot., Cycloid, Polynomial and B-Spline.
- Resolution: the resolution of current section. The resolution setting should be specified according to the equipment requirements. The equipment operates smoother with a higher resolution, however the E-CAM data size also grows bigger with higher resolution.

After the E-CAM editing is completed, you can use *CamTable* of MC\_CamIn to specify the **Name** or the **Item ID** of the E-CAM chart. The specified E-CAM chart will be applied in the E-CAM operation when the two instructions are enabled or executed. For detailed explanations of the two instructions, refer to **AH Motion Controller – Motion Control Instructions Manual**

MC_CamIn		0
Execute	InSync	
ContinuousUpdate	EndOfProfile	
CamTable	Busy	
Periodic	Active	
MasterAbsolute	Abort	
SlaveAbsolute	Error	
MasterOffset	ErrorID	
SlaveOffset		
MasterScaling		
SlaveScaling		
MasterStartDistance		
MasterSyncPosition		
ActivationMode		
StartMode		
Velocity		
Acceleration		
Deceleration		
Jerk		
MasterValueSource		
BufferMode		
Master		
Slave		

### Importing the Recorded E-CAM Data with Master/slave Relation to Create the E-CAM Curves

You can store the master/slave positions in a file, and then import the relation into a cam chart in ISPSOft. The steps of importing the E-CAM data into a cam chart in ISPSOft are as follows.

- Record and save the CAM data in CAM\_1.txt.

```
<CAM_INFO>
Resolution=20
IsApplyBSpline=0
0.000000 180.000000
0.119184 180.146939
0.476735 180.587755
1.072653 181.322449
1.906939 182.351020
2.979592 183.673470
4.290613 185.289796
5.840001 187.200000
7.627755 189.404081
9.653879 191.902042
11.918368 194.693878
14.421225 197.779593
17.162451 201.159185
20.142040 204.832653
23.360003 208.800001
26.816326 213.061226
30.511021 217.616325
34.444084 222.465305
38.575516 227.499596
42.665310 232.067760
46.673477 236.061230
50.600002 239.480003
54.444901 242.324081
58.208164 244.593468
```

- Open an **E-CAM Chart** window in ISPSOft.

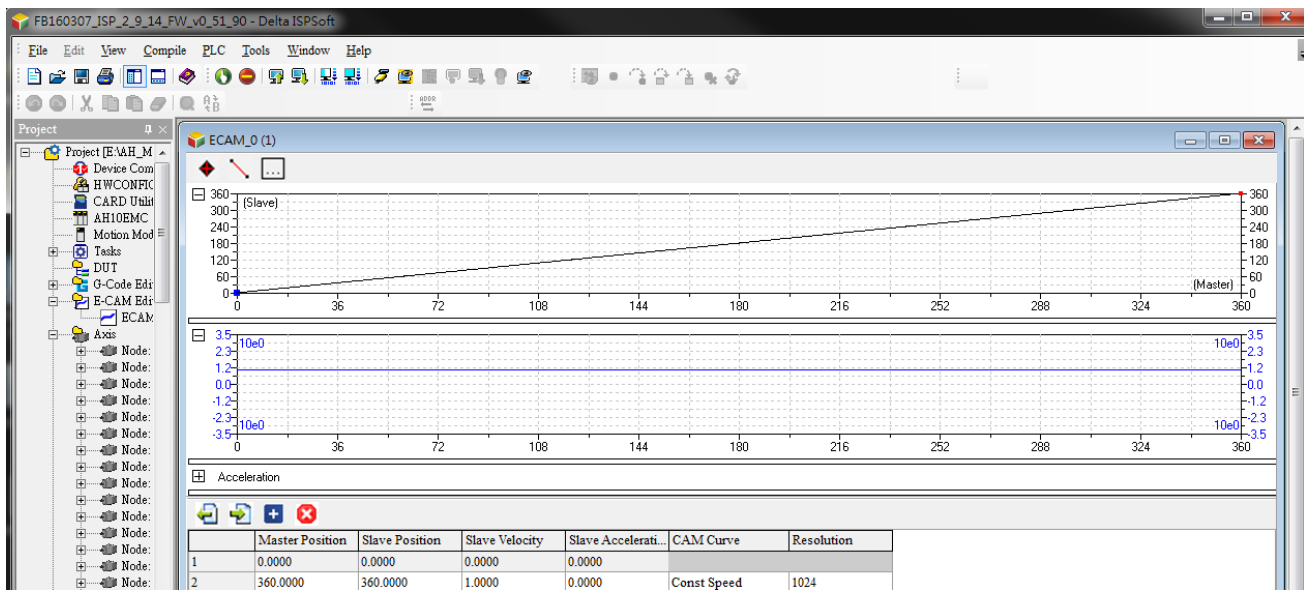

- After  is clicked, select the file CAM\_1.txt to import the recorded CAM data. Click **Open**, and the E-CAM curves will be drawn on the E-CAM Chart as below.

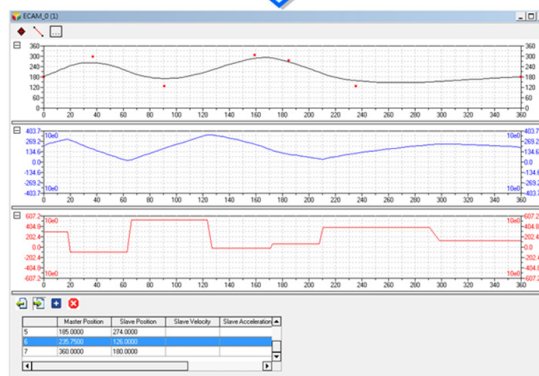
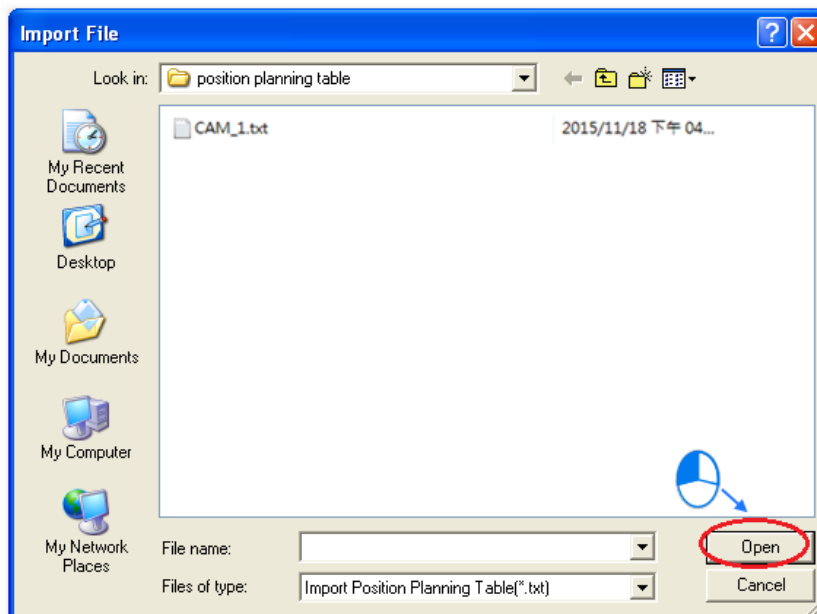

### Modifying the E-CAM Data Directly in the Program

After you create electronic cam data in a cam chart in ISPSOft, the cam data will be downloaded to an AH Motion Controller CPU. If you modify the electronic cam data in ISPSOft, you have to download the new electronic cam data created to the AH Motion Controller CPU again after you modify the electronic cam data. If you want to modify the electronic cam data in the program, you can use function block instructions.

DFB\_CamMultiRead is used to read a particular point in a cam chart, and DFB\_CamMultiWrite is used to modify a particular point in a cam chart.

DFB_CamMultiRead		DFB_CamMultiWrite	
En	Eno	En	Eno
CamTableId	Valid	CamTableId	Done
Enable	Error	Execute	Busy
ReadStartPointNo	ErrorID	WriteStartPointNo	Error
ReadAmount	MasterPosition	WriteAmount	ErrorID
	SlavePosition	MasterPosition	
		SlavePosition	

### 7.9.4 Application of an Electronic Cam—Using a Rotary Cutter

In the application of cutting materials on a feeding belt, a traditional approach is that a cutting roller will rotate after a feeding roller rotates for a certain length, and the alternation of feeding materials and cutting the materials is repeated. The disadvantage of this approach is that the acceleration/deceleration needed in order for a feeding roller to rotate/stop decreases production efficiency. As a result, a new approach is that materials are fed continuously. There are two ways of cutting materials on a feeding belt: rotary cut and flying shear. Flying shear is reciprocating motion, while rotary cut is unidirectional motion. The cam curve for rotary cut is different from the cam curve for flying shear. The application of rotary cut is described below.

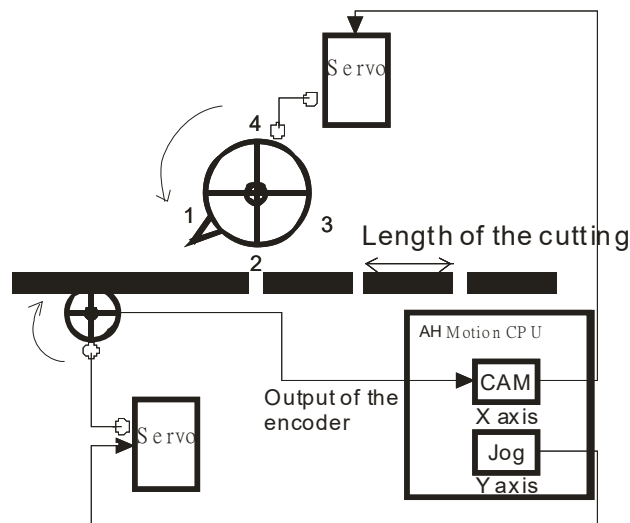

#### 【Concept】

1. In the application of rotary cut, the cutting roller of a rotary cutter rotates in a direction. A material is cut when the blade of the rotary cutter comes into contact with the material. The feeding roller of the rotary cutter continuously feeds materials at a uniform speed. The relation between rotary cut and the output generated is shown below.
  - At first, the slave axis accelerates until it moves to the synchronization zone.
  - After the slave axis leaves the synchronization zone, it decelerates until it returns home. A cycle is complete when the slave axis is at home. You can draw a speed relation chart.

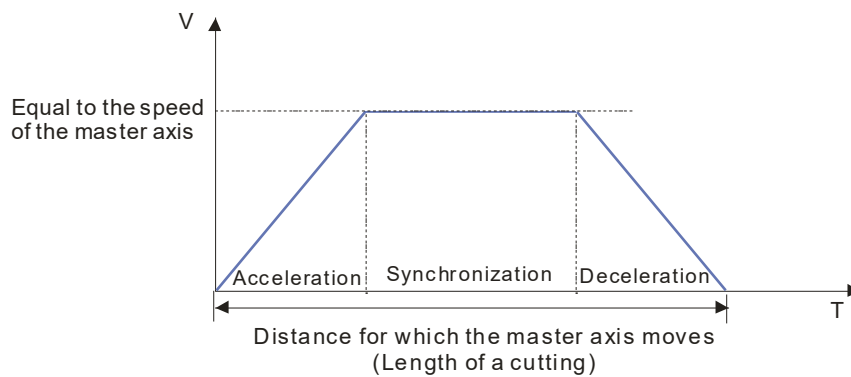
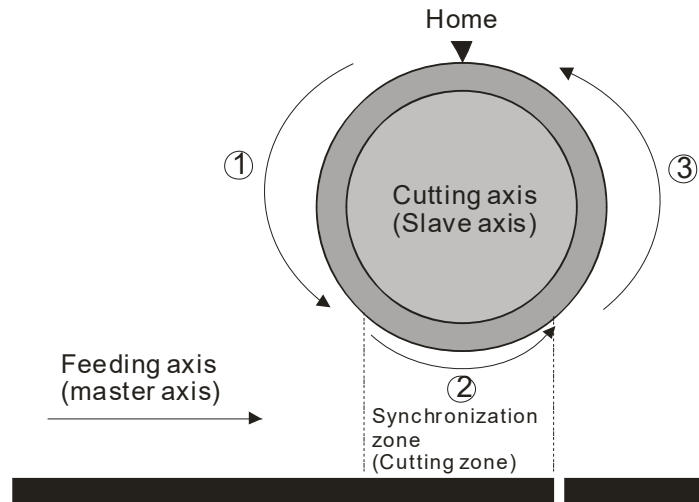

2. During the processing of cutting materials, synchronization is an important factor. When the blades of a rotary cutter come into contact with a material, the speed of the blade must be the same as the speed of the material. If the speed of the blade of a rotary cutter is greater than the speed of a material when it comes into contact with the material, the force which pulls the material forward will appear, and the material will be cut smoothly. If the speed of the blade of a rotary cutter is less than the speed of a material when it comes into contact with the material, the material will be jammed.
3. The design of a synchronization zone affects the operation of equipment. The bigger the synchronization zone is in a cycle, the less time it takes for the slave axis specified to accelerate/decelerate. If equipment needs to accelerate/decelerate in a short time, there will be a great impact on the electric machinery used and the blade used, and there will be an overcurrent passing through the servo used.
4. Relation between the length of a cutting and the circumference of a blade
  - Length of a cutting < Length of the blade used: The speed of cutting roller used is the same as the speed of the feeding roller used in the synchronization zone designed. After the cutting roller used leaves the synchronization zone, the cutting roller will accelerate.

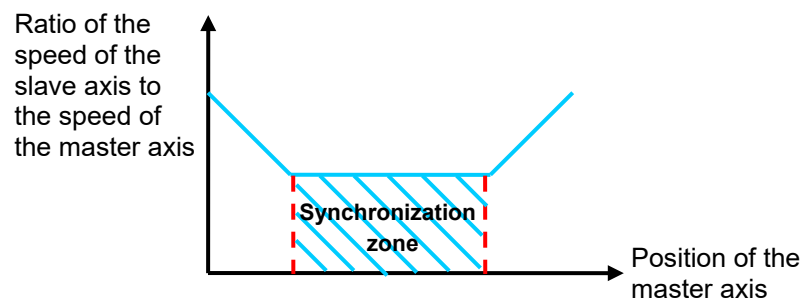



- Length of a cutting=Circumference of the blade used: The cutting roller used rotates at a uniform speed.



- One time the circumference of the blade used < Length of a cutting < Two times the circumference of the blade used: After the cutting roller used completes cutting in the synchronization zone designed, it will decelerate, and then accelerate until its speed is the same the speed of the feeding roller used.

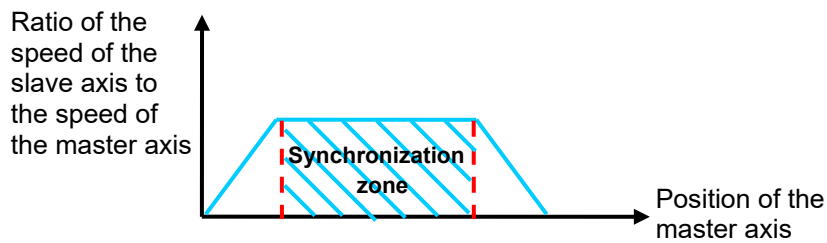

- Length of a cutting > Two times the circumference of the blade used: The length of a cutting is greater than two times the circumference of the blade. (It is a common situation.) After the blade used completes cutting in a cycle, it will decelerate until it stops. After a material of a certain length is fed, the blade used will start cutting again.

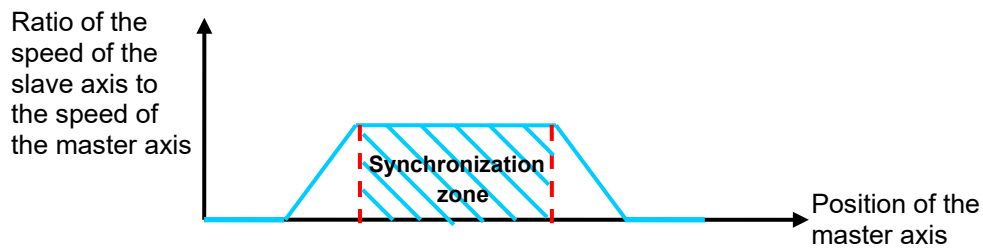

### 7.9.4.1 Creating Rotary Cut Data

You can create a rotary cut E-CAM curve by means of the motion control function block DFB\_CamCurve2 and DFBCamCurveUpdate2.

#### ● Function Block — DFB\_CamCurve2

1. Creating a cam chart: You have to create a blank cam chart in ISPSOFT, and then set resolution in accordance with the number of rotary cut curves. In order to create a rotary cut curve, you need to type 300 in the **Resolution** box. Download the cam chart to an AH Motion Controller CPU. When the AH Motion Controller CPU operates, electronic cam data is stored in the cam chart.

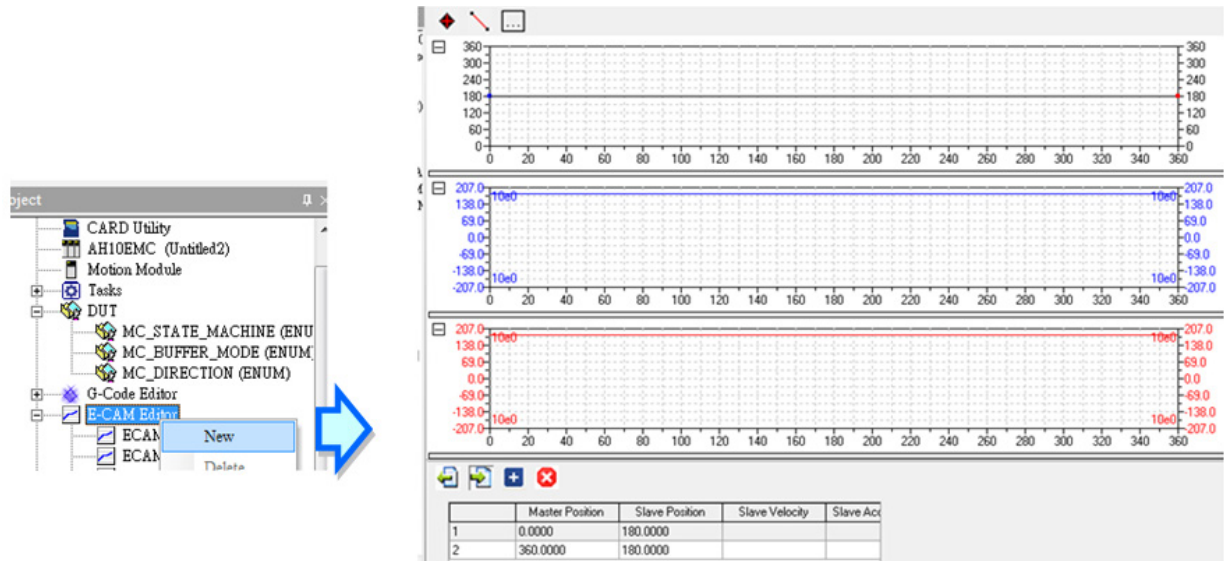

2. Setting DFB\_CamCurve2: You have to set the parameters related to a rotary cutter, including the distance for which the master axis specified moves, the distance for which the slave axis specified is synchronized with the master axis specified, and the synchronization ratio of the speed of the slave axis specified to the speed of the master axis specified. After the motion control function block DFB\_CamCurve2 is executed, a rotary cut curve will be created.

DFB_CamCurve2	
En	Eno
Slave	Done
Execute	Busy
MLength_P	Error
SLength_P	ErrorID
SSyncLength_P	SyncBegin
SSyncRatio	SyncEnd
SMaxRatio	
AccCurve	
eCamCurve	
Concatenate	

● **Inputs**

Name	Function	Data type	Setting value (Default value)	Timing for updating
Execute	Executes the instruction to create the cam curve	BOOL	True/False (False)	-
MLength_P	Specifies the moving distance for master axis.	DWORD	K1~K2,147,483,647 (0)	When <i>Execute</i> shifts to True and <i>Busy</i> is False.
SLength_P	Specifies the moving distance for slave axis.	DWORD	K1~K2,147,483,647 (0)	When <i>Execute</i> shifts to True and <i>Busy</i> is False.
SSyncLength_P	Specifies the synchronized distance for the slave axis.	DWORD	K1~K2,147,483,647 (0)	When <i>Execute</i> shifts to True and <i>Busy</i> is False.
SSyncRatio	Specifies the synchronization ratio between master and slave axes.	REAL	1.1755x10 <sup>-38</sup> ~ 3.4028x10 <sup>+38</sup> (0)	When <i>Execute</i> shifts to True and <i>Busy</i> is False.
SMaxRatio	Specifies the max. cam synchronization ratio between master and slave axes.	REAL	1.1755x10 <sup>-38</sup> ~ 3.4028x10 <sup>+38</sup> (0)	When <i>Execute</i> shifts to True and <i>Busy</i> is False.
AccCurve*1	Selects the acceleration curve in the cam profile.	WORD	0~3 (0)	When <i>Execute</i> shifts to True and <i>Busy</i> is False.
eCamCurve*2	Selects the cam curve type.	WORD	0~9 (0)	When <i>Execute</i> shifts to True and <i>Busy</i> is False.
Concatenate	Defines if reciprocal operation is required. True: periodical False; non-periodical	BOOL	True/False (False)	When <i>Execute</i> shifts to True and <i>Busy</i> is False.

**\*Note:**

1. Set value of *AccCurve*. Refer to **Function** of this instruction for the cam profiles of each acceleration curve.

Value	Definition
0	Constant speed
1	Const Acceleration
2	SingleHypot
3	Cycloid

2. Set value of *eCamCurve*. Refer to **Function** of this instruction for the cam profiles of each type.

Value	Definition
0	leftCAM
1	midCAMall
2	midCAMbegin

3	midCAMend
4	rightCAM
5	rightCAM
7	midCAMbegin
8	midCAMend
9	Empty

### ● Outputs

Name	Function	Data type	Output range (Default value)
Done	True when the cam curve is established.	BOOL	True/False (False)
Busy	True when the instruction is executed.	BOOL	True/False (False)
Error	True if an error occurs.	BOOL	True/False (False)
ErrorID	Indicates the error code if an error occurs. Refer to <b>Appendices</b> for error code descriptions.	DWORD	0x0000, 0x3100, 0x3101, 0x3102 (0)
SyncBegin	Records the beginning position of the Synchronization zone	DWORD	K0~K2,147,483,647 (0)
SyncEnd	Records the ending position of the Synchronization zone	DWORD	K0~K2,147,483,647 (0)

### ● In-Outs

Name	Function	Data type	Setting value (Default value)	Timing for updating
Slave	Slave axis number	WORD	K1~K32 (0)	When <i>Enable</i> is rising edge triggered and <i>Busy</i> is False.

● **Function**

■ **AccCurve**

0: Const speed

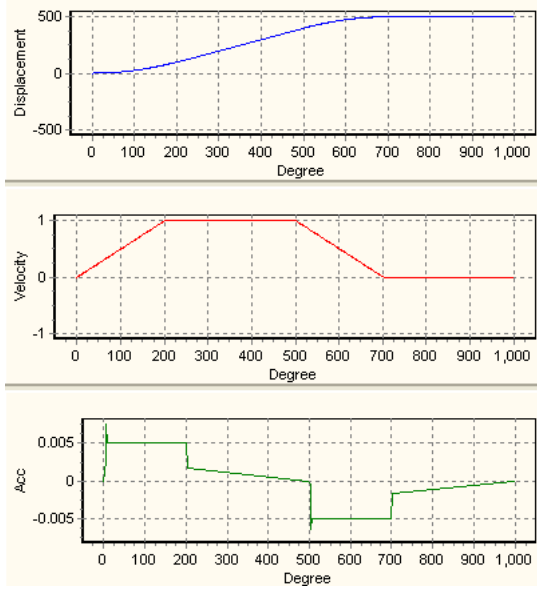

1: Constant Acceleration

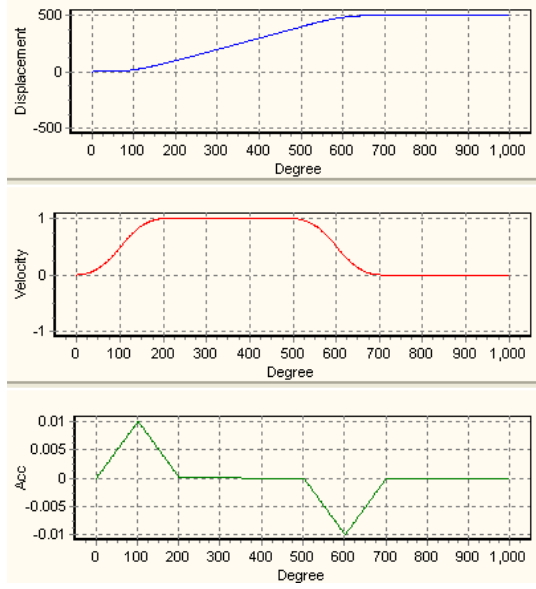

2: SingleHypot

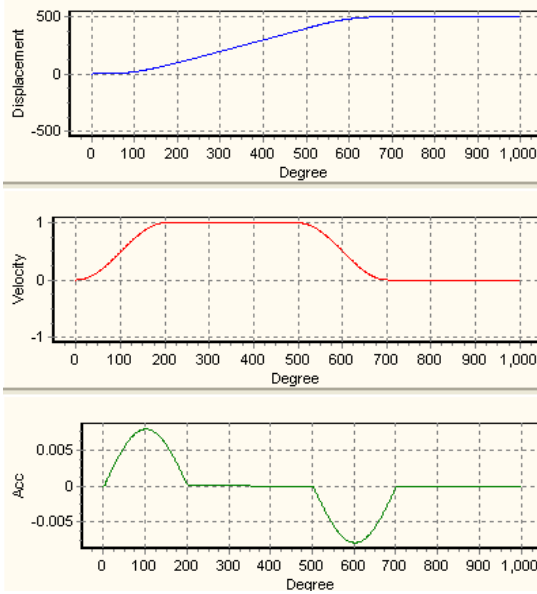

3: Cycloid

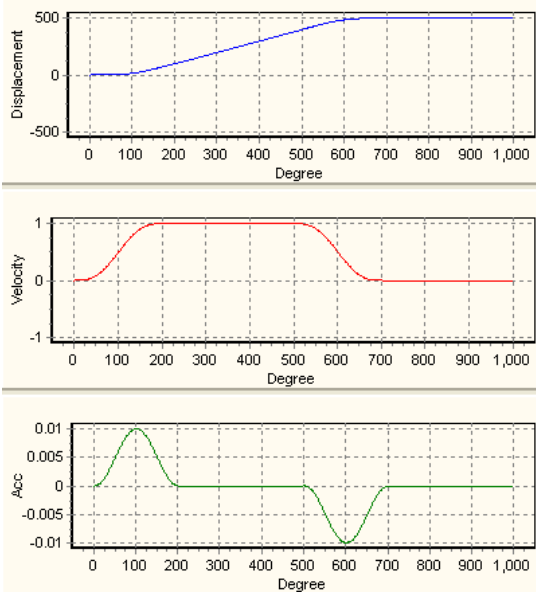

7

■ **eCamCurve**

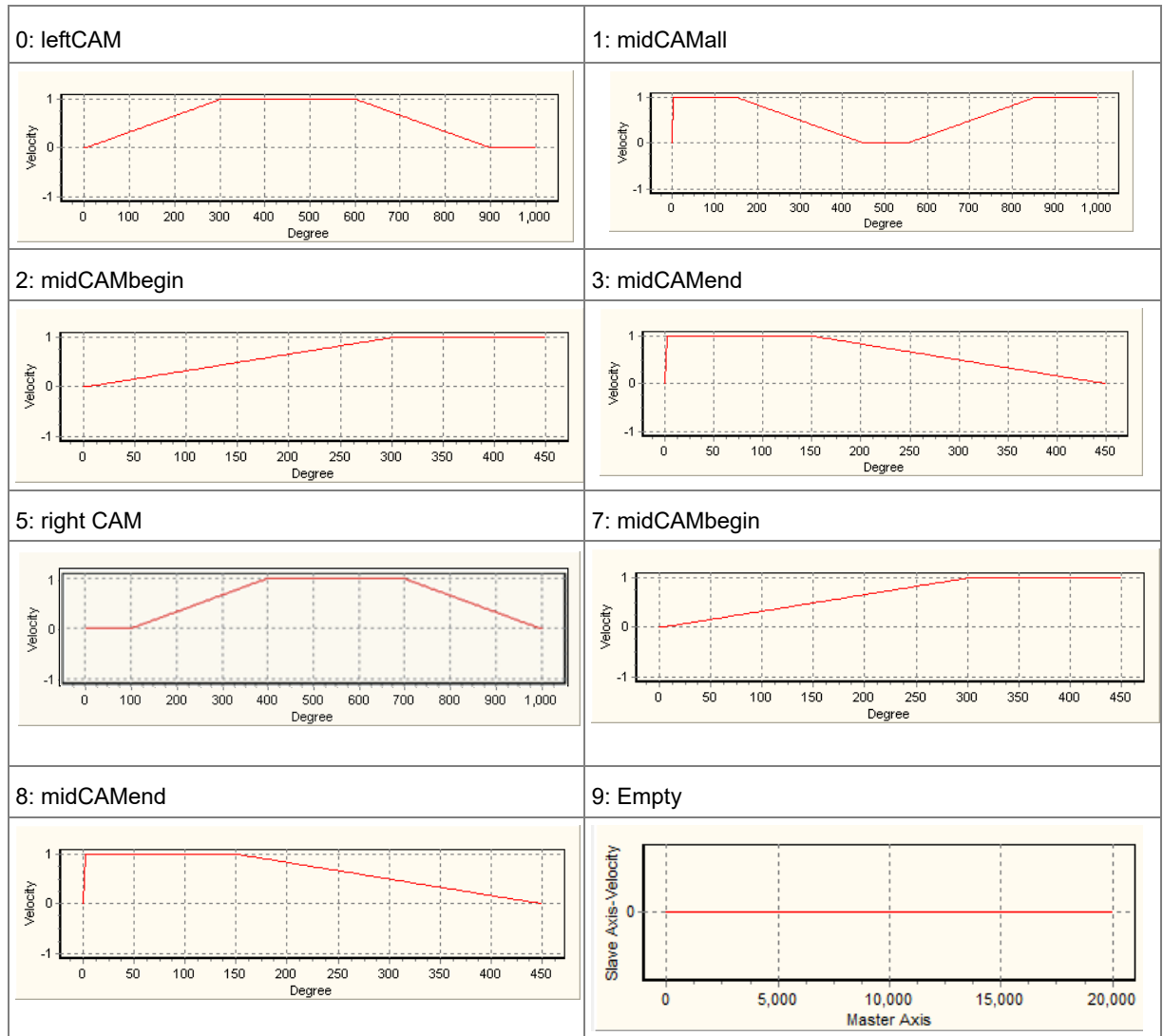

● **Example**

The parameters of creating a rotary cut curve by means of the motion control function block DFB\_CamCurve2 are described below.

Distance for which the master axis specified moves=1000

Distance for which the slave axis specified moves=500

Distance for which the slave axis specified is synchronized with the master axis specified=300

Synchronization ratio of the speed of the slave axis specified to the speed of the master axis specified=1.0

The rotary cut curve created and the values of parameters are shown below.

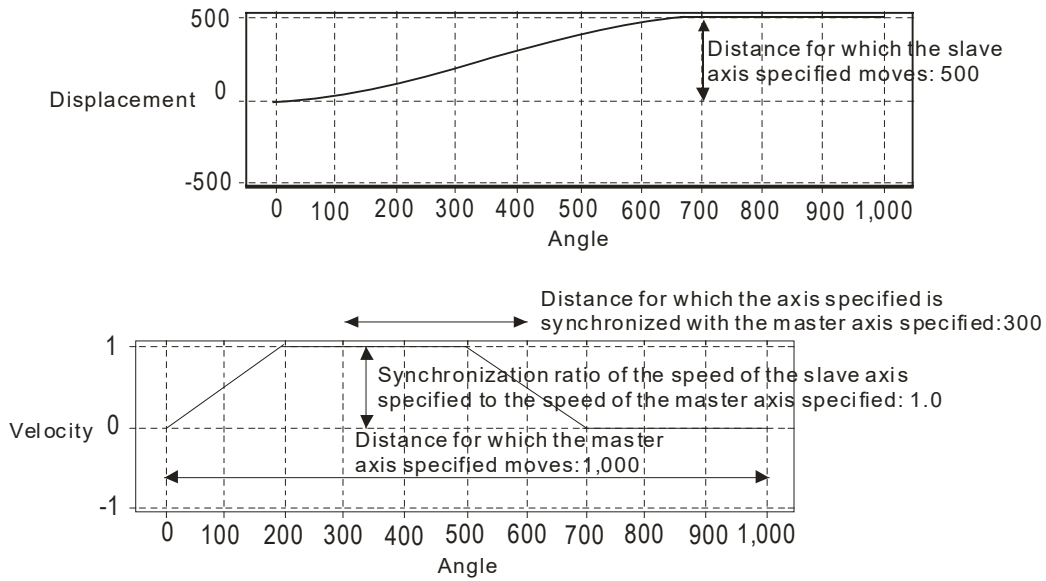

Parameter	Setting value
Distance for which the master axis specified moves	1000
Distance for which the slave axis specified moves	500
Distance for which the slave axis specified is synchronized with the master axis specified	300
Synchronization ratio of the speed of the slave axis specified to the speed of the master axis specified	1.0
Maximum ratio of the speed of the slave axis specified to the speed of the master axis specified	10.0
Acceleration curve	0
Cam curve	0
Concatenation	0

【Steps】

- Download the program created to an AH Motion Controller CPU, and then execute the program.
- After M1 is set to True, a rotary cut curve will be created.

【Program in ISPSOft】

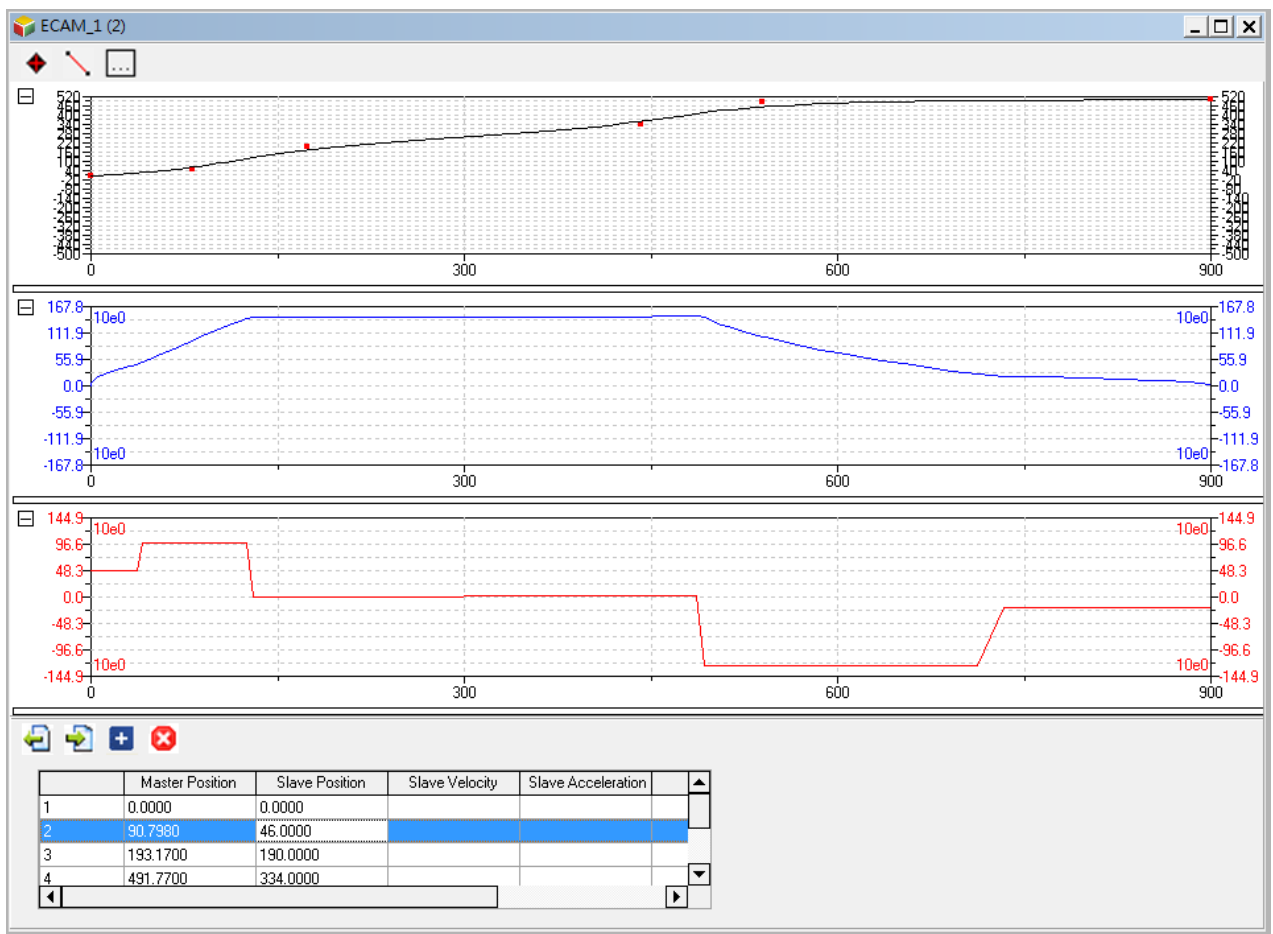
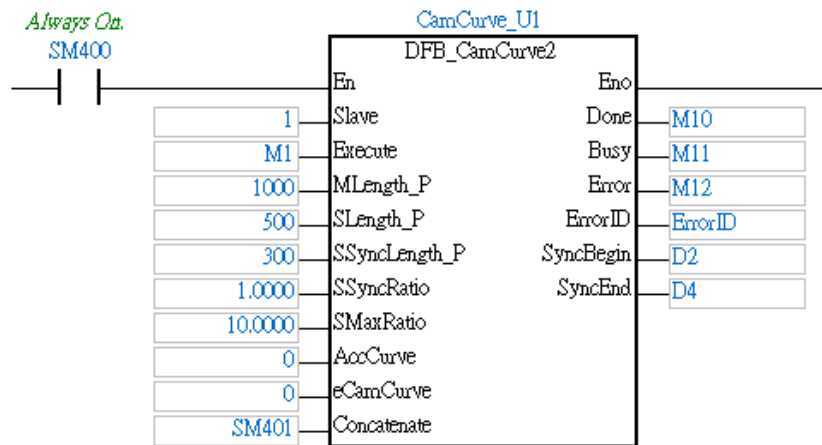



● **Function Block—DFB\_CamCurveUpdate2**

After DFB\_CamCurve2 is executed, DFB\_CamCurveUpdate2 can be used. If you want to modify a rotary cut curve, you can create a new rotary cut curve by DFB\_CamCurve2, and then update the rotary cut curve by DFB\_CamCurveUpdate2.



● **Inputs**

Name	Function	Data type	Setting value (Default value)	Timing for updating
Execute	Executes the instruction to update the cam profile.	BOOL	True/False (False)	-

● **Outputs**

Name	Function	Data type	Output range (Default value)
Done	True when the cam curve is established.	BOOL	True/False (False)
Busy	True when the instruction is executed.	BOOL	True/False (False)
Error	True if an error occurs.	BOOL	True/False (False)
ErrorID	Indicates the error code if an error occurs. Refer to <b>Appendices</b> for error code descriptions.	DWORD	0x0000, 0x3100, 0x3101, 0x3102 (0)

---

## Chapter 8 Memory Card

### Table of Contents

<b>8.1</b>	<b>Overview of Memory Cards .....</b>	<b>8-2</b>
8.1.1	Appearances of Memory Cards.....	8-2
8.1.2	Specifications for SD Cards .....	8-2
<b>8.2</b>	<b>Using a Memory Card .....</b>	<b>8-3</b>
8.2.1.	Formatting a Memory Card.....	8-3
<b>8.3</b>	<b>Installing and Removing a Memory Card.....</b>	<b>8-5</b>
8.3.1.	SD Slot in a CPU .....	8-5
8.3.2.	Installing a Memory Card .....	8-6
8.3.3.	Removing a Memory Card .....	8-6
<b>8.4</b>	<b>Contents of a Memory Card .....</b>	<b>8-7</b>
8.4.1.	Initializing a Memory Card .....	8-7
8.4.2.	Folder Structure in a Memory Card.....	8-7
<b>8.5</b>	<b>Reading/Writing a Memory Card .....</b>	<b>8-8</b>
8.5.1.	Backing up the System .....	8-8
8.5.2.	Restoring the System .....	8-8
<b>8.6</b>	<b>CARD Utility .....</b>	<b>8-8</b>
<b>8.7</b>	<b>Backup .....</b>	<b>8-10</b>
<b>8.8</b>	<b>Restoration .....</b>	<b>8-14</b>

## 8.1 Overview of Memory Cards

The AH Motion Controller CPU supports Micro SD cards. Users can purchase products which meet specifications. The specifications for the SD cards supported by the AH Motion Controller CPUs, and the usage of the SD cards are described in this chapter.

### 8.1.1 Appearances of Memory Cards

SD cards are classified into three types according to size. They are SD cards, miniSD cards, and microSD cards. The AH Motion Controller CPU supports Micro SD cards.

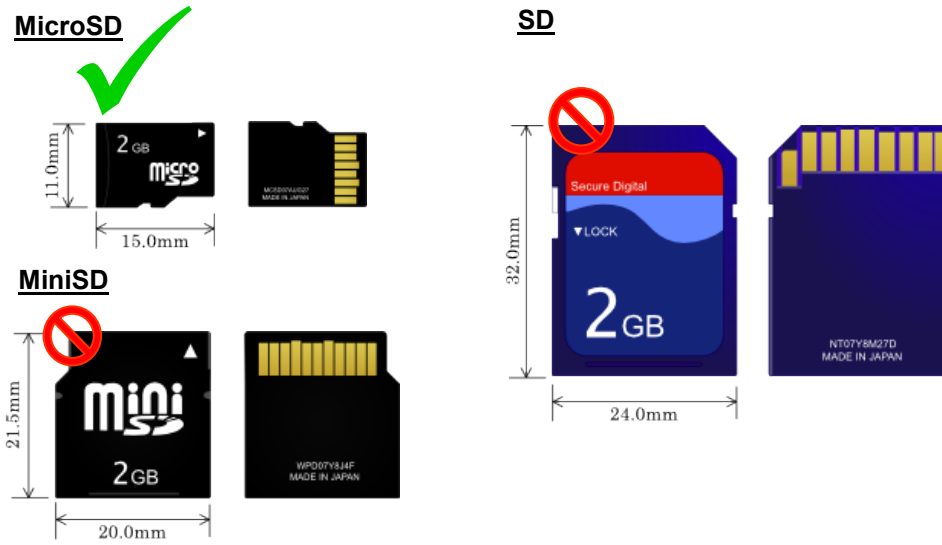

### 8.1.2 Specifications for SD Cards

There are several specifications for SD cards on the market. SD cards not only can be classified according to size, but also can be classified into three types according to capacity. These types are SD cards, SDHC cards, and SDXC cards. The AH Motion Controller CPU presently support SD and SDHC specifications with micro size. The following is the table of SD card families. Be sure to purchase products which meet the specifications.

- The SD card families

Type	SD		SDHC			SDXC	
Capacity	2GB Max.		4GB ~ 32GB			32GB ~ 2TB	
File system	FAT/FAT32		FAT32			exFAT	
Size	SD	Micro SD	SDHC	Mini SDHC	Micro SDHC	SDXC	Micro SDXC
Speed class rating	N/A		Class 2 (Min. 2 MB/sec.) Class 4 (Min. 4 MB/sec.) Class 6 (Min. 6 MB/sec.) Class 10 (Min. 10 MB/sec.)			Class 2 (Min. 2 MB/sec.) Class 4 (Min. 4 MB/sec.) Class 6 (Min. 6 MB/sec.) Class 10 (Min. 10 MB/sec.)	

## 8.2 Using a Memory Card

### 8.2.1. Formatting a Memory Card

A memory card that you use for the first time may not yet be formatted. The memory card which is not formatted can not be used in an AH Motion Controller CPU. Therefore, you need to format the memory card. The file system with which the memory card is formatted is FAT(FAT16)/FAT32.

The following example introduces the most common way to format an SD card, that is, formatting an SD card through a card reader. However, you still need to read the documents provided by the SD card manufacturer carefully.

**⚠** If a memory card is formatted, all the data in the memory card will be deleted. You have to check whether the data in a memory card needs to be backed up before you format the memory card.

- (1) When using MicroSD to SD card adapter, slide the write protect tab on the left side of the memory card upward, and then insert it into a card reader. The operating system detects a new storage device.

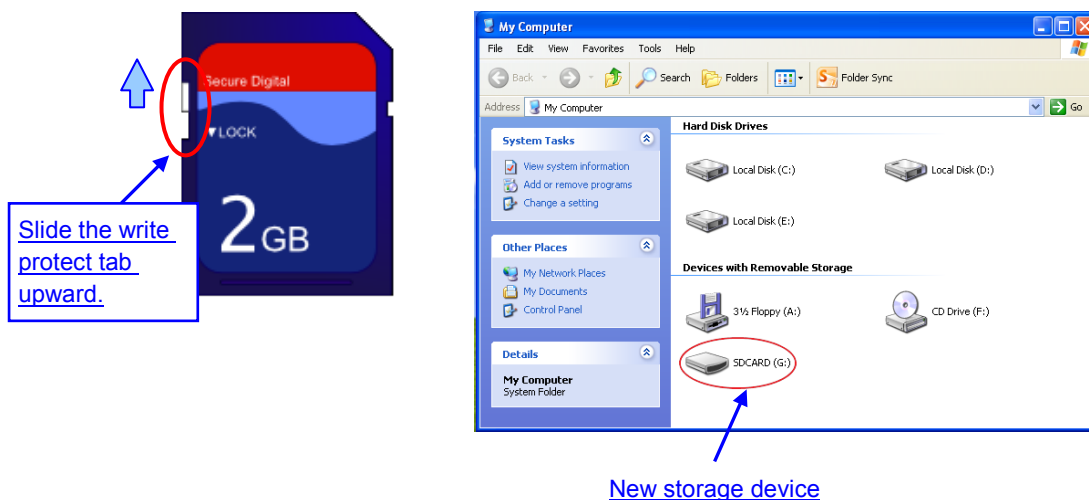

- (2) Right-click the new storage device and then click **Format**.

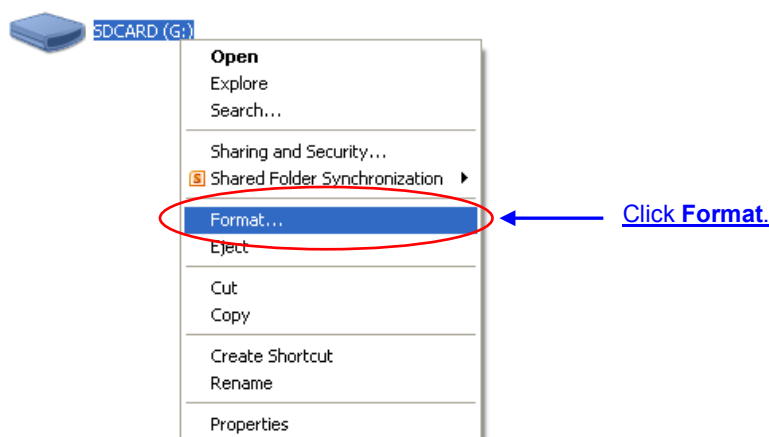

- (3) The file system with which the memory card is formatted must be FAT. The other default setting is retained. Click **Quick Format**, and then click **Start**.

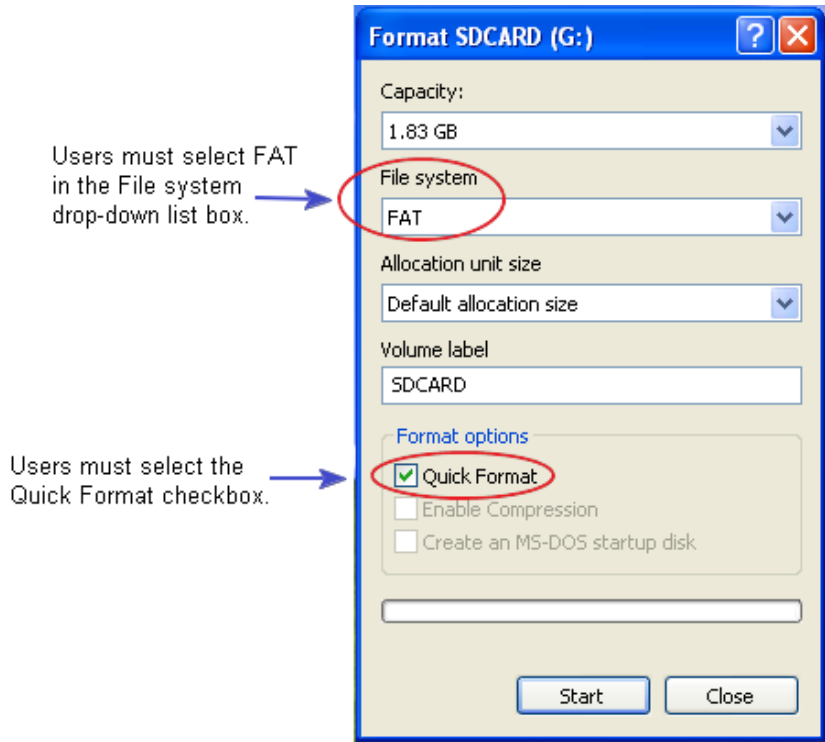

- (4) After **OK** in the warning window is clicked, the SD card is formatted.

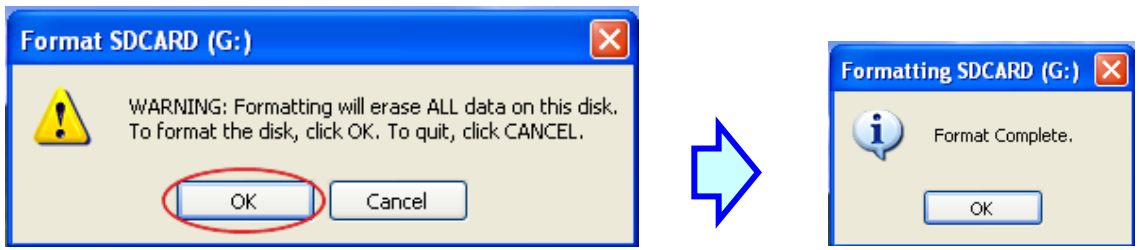

### 8.3 Installing and Removing a Memory Card

#### 8.3.1. SD Slot in a CPU

As shown below, the SD slot is in the middle right area of the front of a CPU.

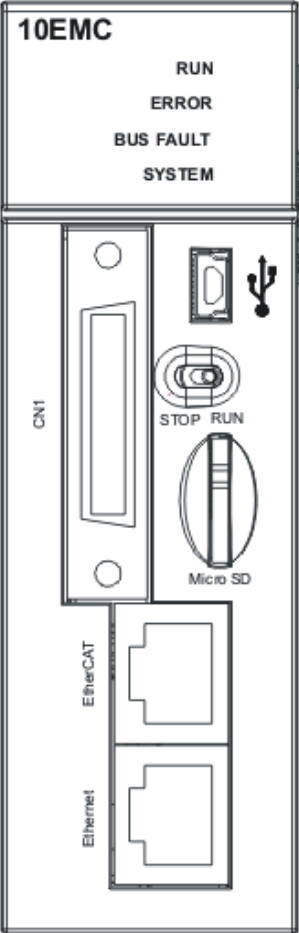

### 8.3.2. Installing a Memory Card

Insert a memory card into the SD slot in a CPU, and push it downward until it clicks. After the memory card is installed, it is fixed firmly in the slot. If the memory card is loose, it is not installed correctly. Besides, the memory card has anti-misinsertion design. If it is inserted in the wrong direction, it can not be pushed downward. To prevent the CPU from being damaged, you can not force the memory card in. The correct way to insert the memory card is shown below.

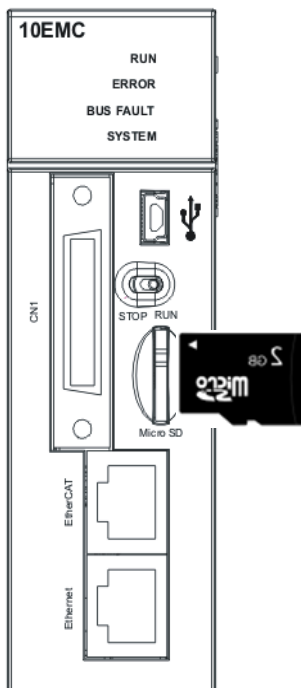

### 8.3.3. Removing a Memory Card

After a memory card is pushed downward, the slot will eject the SD card and you can take it out.

## 8.4 Contents of a Memory Card

### 8.4.1. Initializing a Memory Card

The system initializes the SD card when power is supplied to a CPU or stop to run

### 8.4.2. Folder Structure in a Memory Card

The default folder group used by an AH system is shown below. The folder name is AH500, which includes AH500 series CPUs and AH Motion Controller CPUs. Several subfolders are contained inside the AH500 folder. Related files created by users and the AH system are stored in the subfolders.

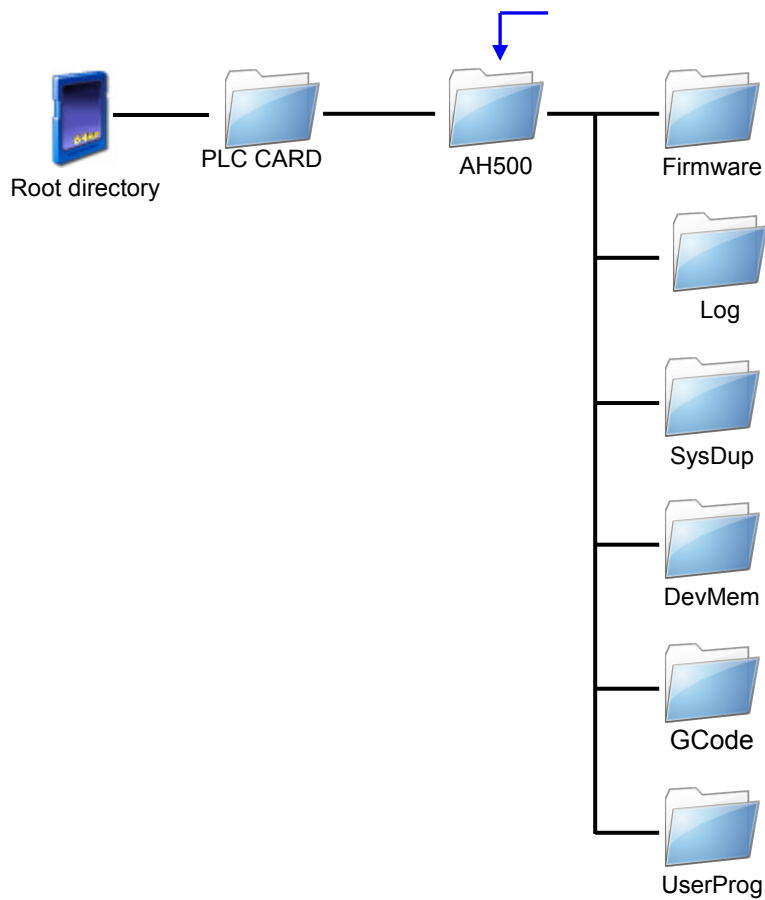

File Folder	Description
Firmware	Firmware file (.lzm)
Log	Error log file (.log)
SysDup	System backup files (.dup)
UserProg	File memory created by instructions (.txt / .dmd / .csv)
GCode	External G-code file (100.nc~227.nc)
FTP	As an external SD card for G-code file (300.nc~400.nc)
DevMem, Setup	Reserved



## 8.5 Reading/Writing a Memory Card

You can read/write data into/from a memory card to back up and update a system by means of the DIP switch on a CPU.

### 8.5.1. Backing up the System

When a system backup is executed, the user program (including G-code, E-CAM..), the parameter setting, the hardware configuration, the network (e.g. EtherCAT) configuration, and the values on the device memories in a CPU are backed up and saved as a file called AUTOEXEC.dup, which is stored in a folder named SysDup in a memory card. If a default path denotes an existing backup file, the previous data in the old backup file is overwritten when a system is backed up.

A system backup can be executed, whether a CPU runs or stops. Please refer to **Section 8.7 Backup** for the system backup procedure.

### 8.5.2. Restoring the System

Before a system restoration is executed, you have to make sure that the backup file AUTOEXEC.dup is stored in a folder named SysDup in a memory card. After the system restoration is executed, the user program, the parameter setting, the hardware configuration, and the network configuration in the memory card are restored to a CPU. In addition, if the data in the backup file includes the values on the device memories, the data restored to the CPU will include the values on the device memories.

If `:/PLC CARD/AH500/SysDup/AUTOEXEC.dup` is valid, the CPU will restore the system automatically after power-on. Please be sure not to put this file in SD card if you don't want to restore the system. You can restore the system by using Card Utility. Please refer to Section 8.9 Restoration.

## 8.6 CARD Utility

There is a microSD slot on AH Motion Controller CPUs. You can back up/restore data in an AH Motion Controller CPU through the use of a memory card. Besides, ISPSOft provides CARD Utility for AH Motion Controller CPUs. You can back up/restore data in an AH Motion Controller CPU or an ISPSOft project through CARD Utility. The program code, the parameter setting, the hardware configuration, and the network configuration in an AH Motion Controller CPU or an ISPSOft project can be backed up. The values in the devices in an AH Motion Controller CPU can also be backed up. Please refer to previous sections or the **AH Motion Controller - Hardware Manual** for more information about the specifications of the SD cards which can be inserted into AH Motion Controller CPUs, and the usage of the SD cards.

The network configuration stored in an AH Motion Controller CPU is the data which is only related to the AH Motion Controller CPU itself. When you back up the network configuration, only the part of the network configuration which is related to the selected AH Motion Controller CPU will be backed up. The part of the network configuration backed up consists of only a routing table and data exchange data. Therefore, if you restore the backup data to an ISPSOft project, the system will not be able to restore the complete data in the NWCONFIG settings.

The functions supported by CARD Utility are described below. The diagram below is a flowchart.

- If you export data in an AH Motion Controller CPU as a backup file (\*.dup), the data exported can be saved in the memory card inserted in the AH Motion Controller CPU, or a folder in the computer. You can decide whether to include the values in the devices in the AH Motion Controller CPU.
- If you export an ISPSOft project as a backup file (\*.dup), the ISPSOft project exported can only be saved in a folder in the computer, and the values in the devices in the AH Motion Controller CPU are not backed up.
- You can restore the backup file (\*.dup) in the inserted memory card to the CPU.
- You can restore the backup file (\*.dup) in a computer to the CPU which is connected, or restore the backup file to an

ISPSOft project. If you choose to restore the backup file to an ISPSOft project, the system will automatically skip the values in the devices and the network configuration in the backup file.

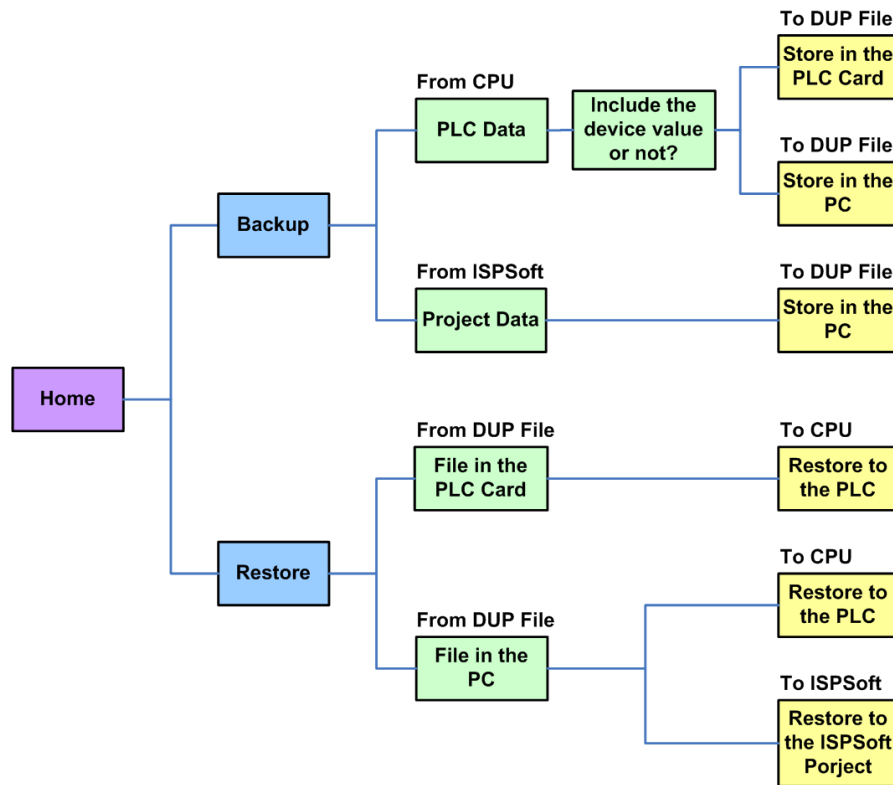

After you double-click **CARD Utility** in the project management area, the system will open the **CARD Utility** window.

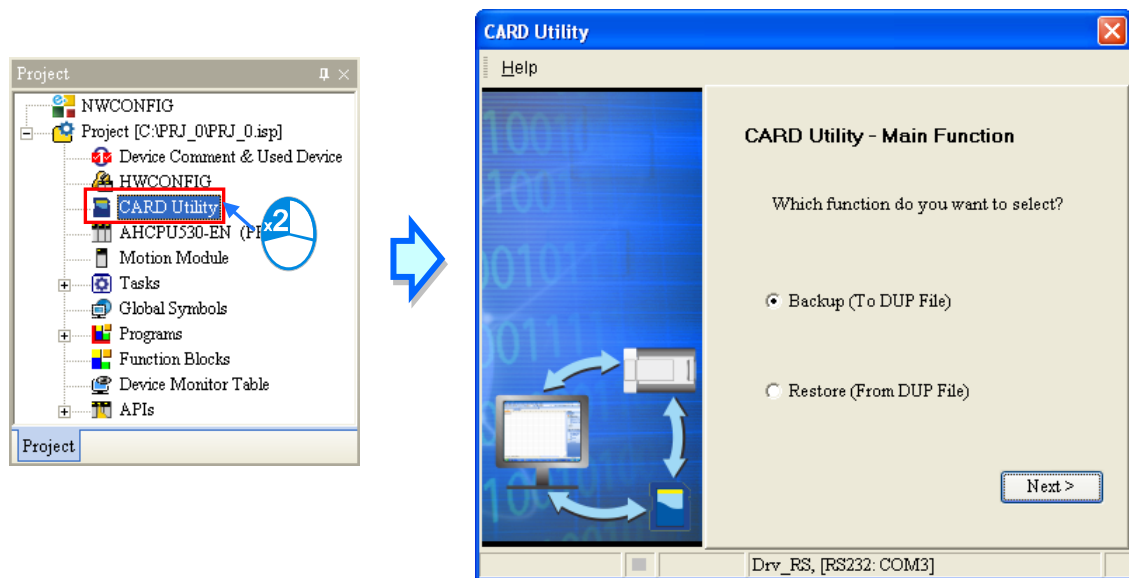

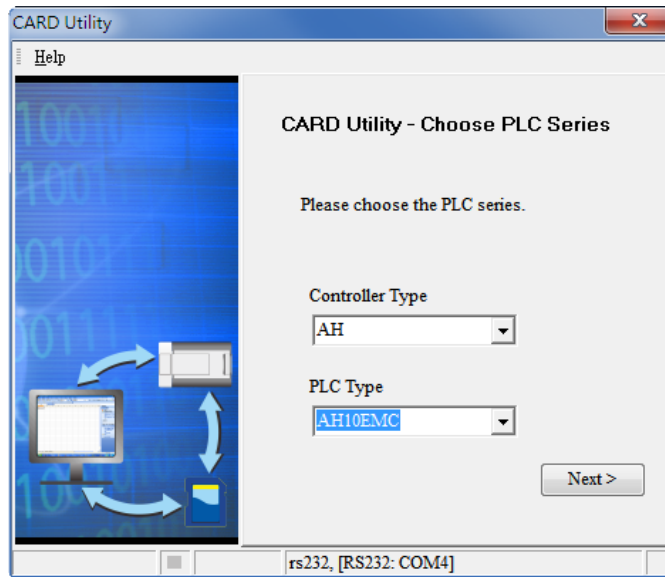

## 8.7 Backup

If the backup source/backup destination is an AH Motion Controller CPU or the memory card inserted in an AH Motion Controller CPU, you have to make sure that ISPSOft is connected to the AH Motion Controller CPU normally. Please refer to **ISPSOft User Manual** for more information about the checking operation.

- (1) Select the **Backup (To DUP File)** option button in the **CARD Utility** window, and then click **Next**.

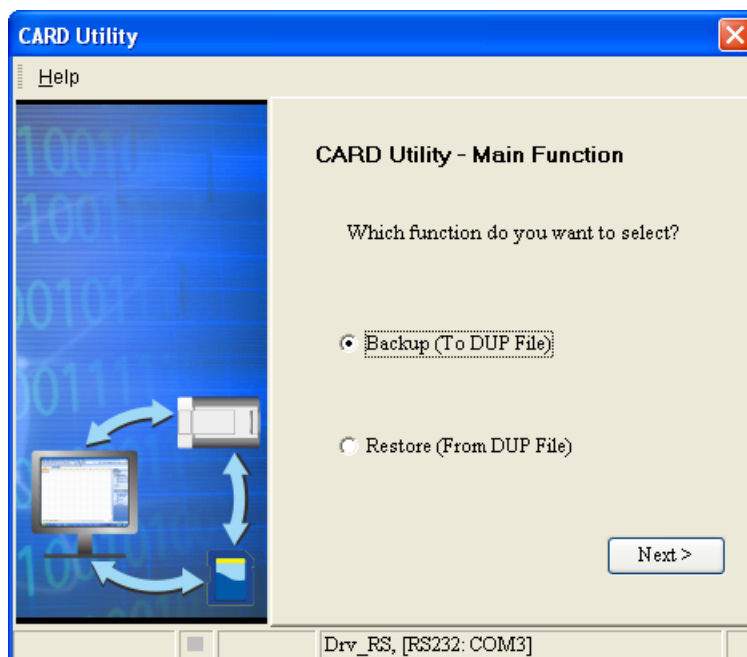

- (2) Select a backup source, and then click **Next**.

After you select the **ISP Project (Compiled and saved)** option button, you have to click **...**, and select an isp file in the **Open** window. If the program in the isp file selected is not compiled, a message appears when the isp file is backed up. Open the isp file with ISPSOft, compile the program in the isp file, and save the isp file. After the program in the isp file is compiled, you can back up the isp file.

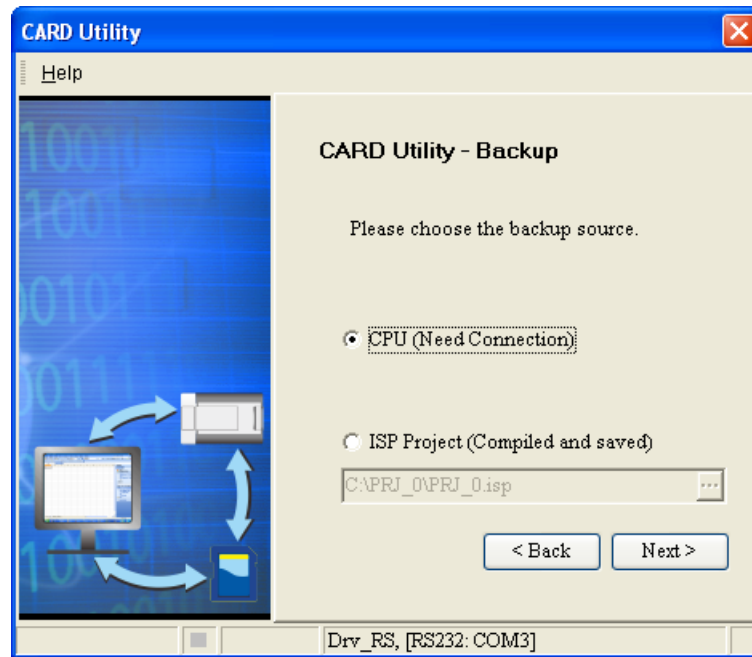

- (3) After you select the **CPU (Need Connection)** option button, you have to decide whether to include the values in the devices in the AH Motion Controller CPU which is connected to ISPSOft.

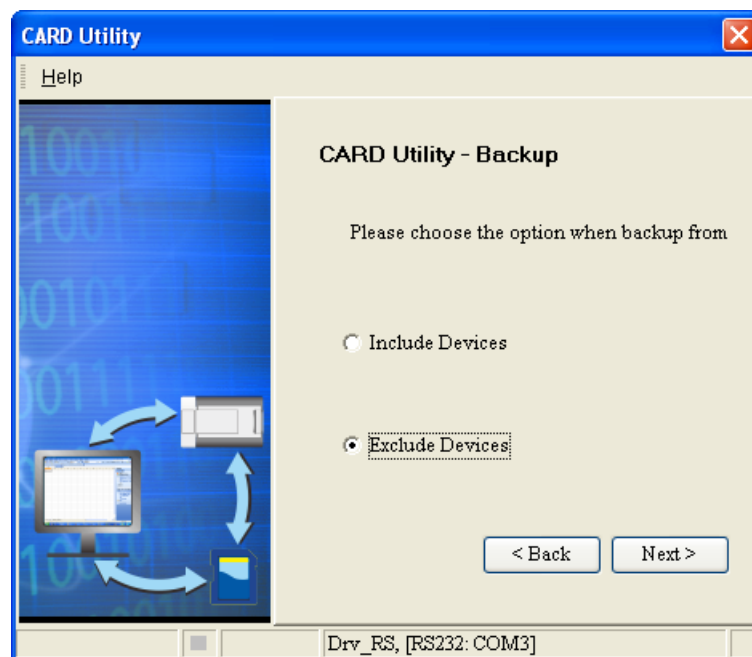

- (4) Select a backup destination. If the backup source is an ISPSOft project, the backup destination must be a computer.
- If the **Memory Card (PLC Side)** button is selected, the filename of the backup file which will be produced will be **AUTOEXEC.dup**, and the path which points to the backup file will be **Root directory of the memory card\AH500\SysDup\AUTOEXEC.dup**.
  - If the **PC (DUP File)** option button is selected, you have to click **...**, and specify the directory and file name for the backup file.

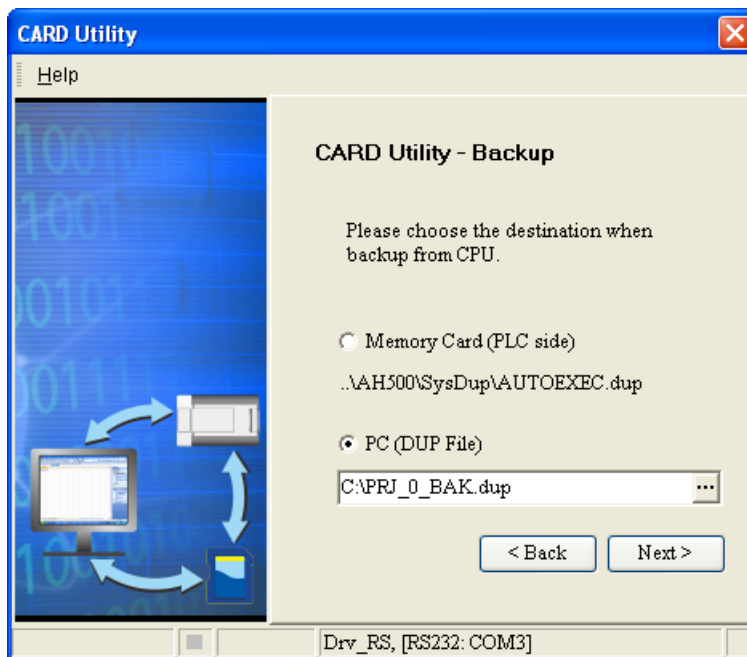

- (5) After a backup destination is specified, you can set passwords for the backup file. You can either select “Same with Project passwrod” or specify a new password by clicking “Setting New PLC Password.”

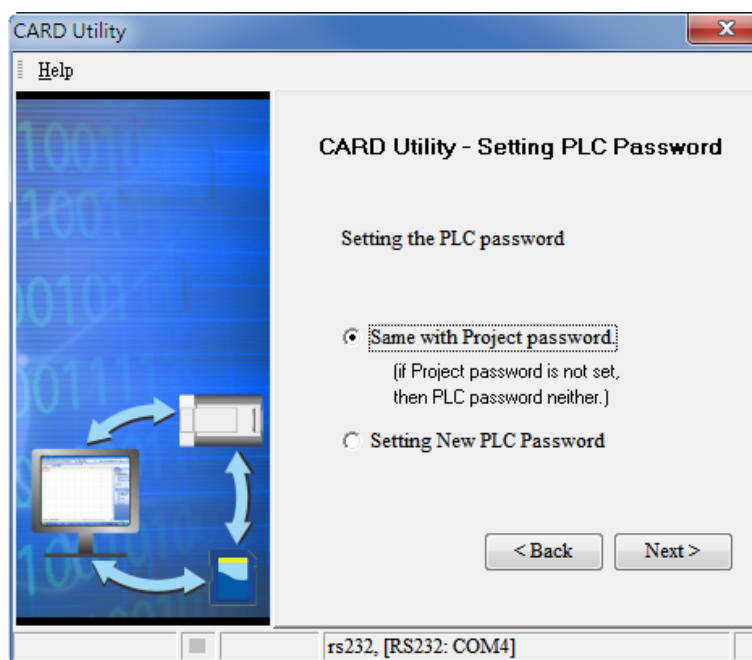

- (6) After you make sure that the summary in the **CARD Utility** window is consistent with the desired data backup operation, you can click **Execute**.

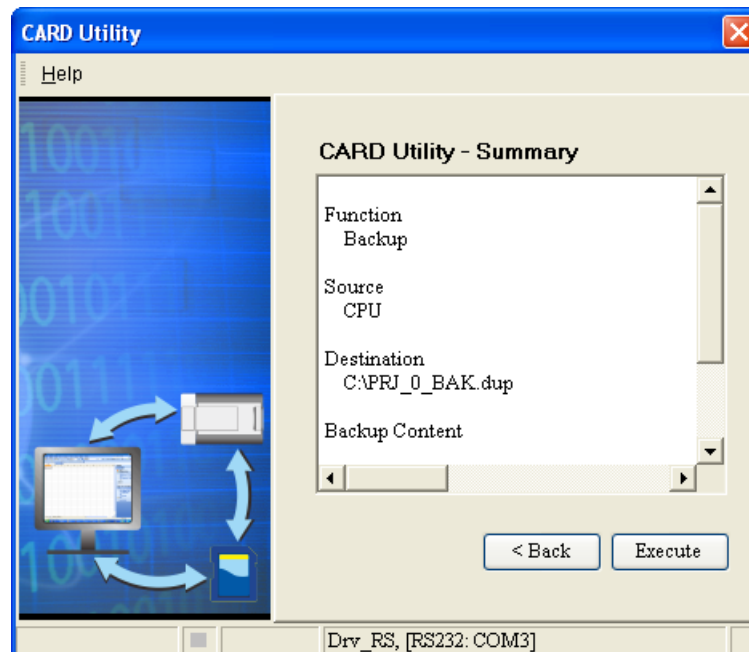

If you clicked **Cancel** to stop ISPSOft from backing up data from the CPU to the memory card, the CPU will be still in data backup process. You can power off the CPU to force stop the process. However, the backup file produced is not a complete backup file. As a result, you have to delete the backup file in the memory card.

Every time when the **Memory Card (PLC Side)** button is selected, the system will execute the backup process with the same folder path and the same file name. If there is an old backup file in the memory card, a **Warning** window will appear. You can click **Replace**, **Archive**, or **Cancel** in the warning window according to your needs.

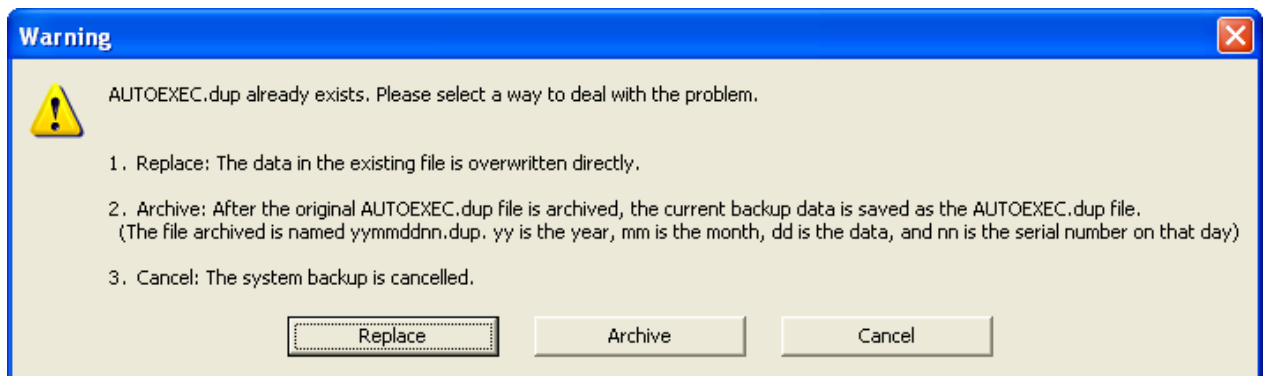

If the data backed up is protected by passwords, these passwords will also be backed up.

Data backup	Description
CPU→Memory card	The data backed up includes the PLC ID and the PLC password set in the CPU.
CPU→Computer	The system will ask users to type a PLC ID and a PLC password. If the PLC ID and the PLC password typed are correct, the data backup will be performed. The data backed up includes the PLC ID and the PLC password.
ISPSOft project→Computer	The data backed up includes the program ID and the project password set in the ISPSOft project.

(7) After the data backup is performed, you can click **Home** or **Close** in the **CARD Utility** window.

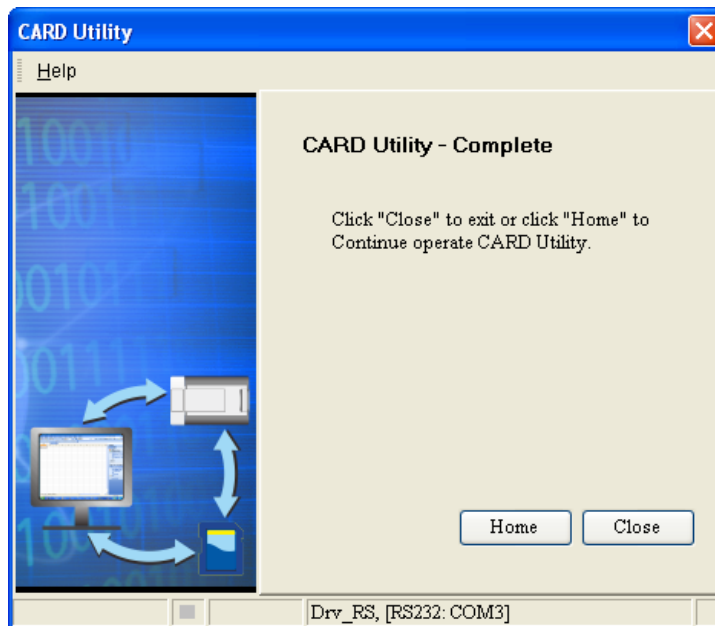

## 8.8 Restoration

If the restoration source/restoration destination is an AH Motion Controller CPU or the memory card inserted in an AH Motion Controller CPU, you have to make sure that ISPSOft is connected to the AH Motion Controller CPU normally. Please refer to **ISPSOft User Manual** for more information about the checking operation.

(1) Select the **Restore (From DUP File)** option button in the **CARD Utility** window, and then click **Next**.

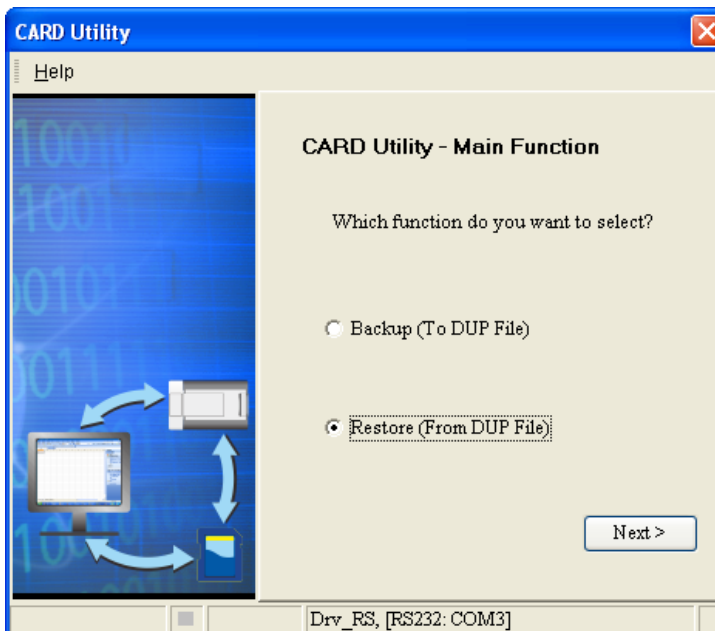

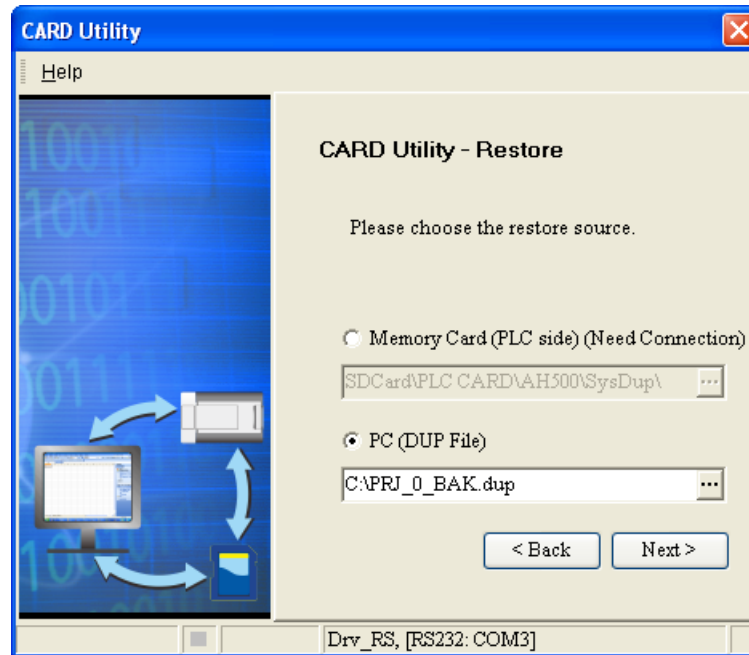

- (2) Select a restoration source, click , and select a backup file.

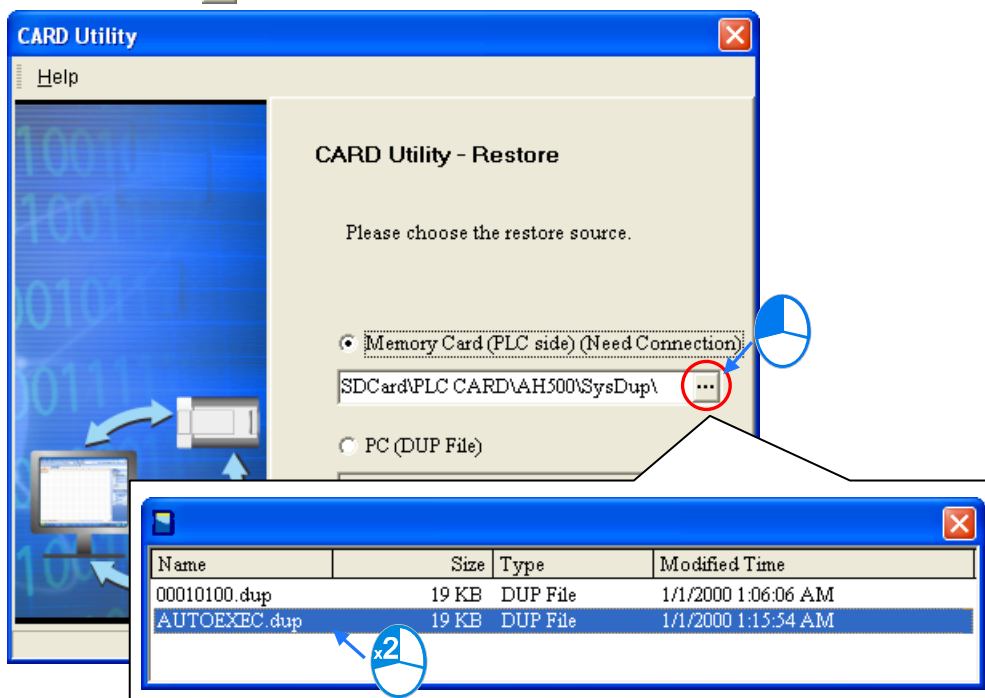

If the **Memory Card (PLC side) (Need Connection)** button is selected, the backup files in the memory card will be displayed in a window after  is clicked. You can double-click a backup file in the window.



- (3) Select a restoration destination, and then click **Next**.
- If you want to restore the selected backup file to the CPU, you have to select the **CPU (Need Connection)** button. If the restoration source is the memory card inserted in the CPU, the restoration destination must be the CPU.
  - If the **ISP Project** button is selected, you have to click . After you click , you can specify a filename and a



path. If the path specified point to a file which exists in the computer, the file will be overwritten after the data restoration is performed.

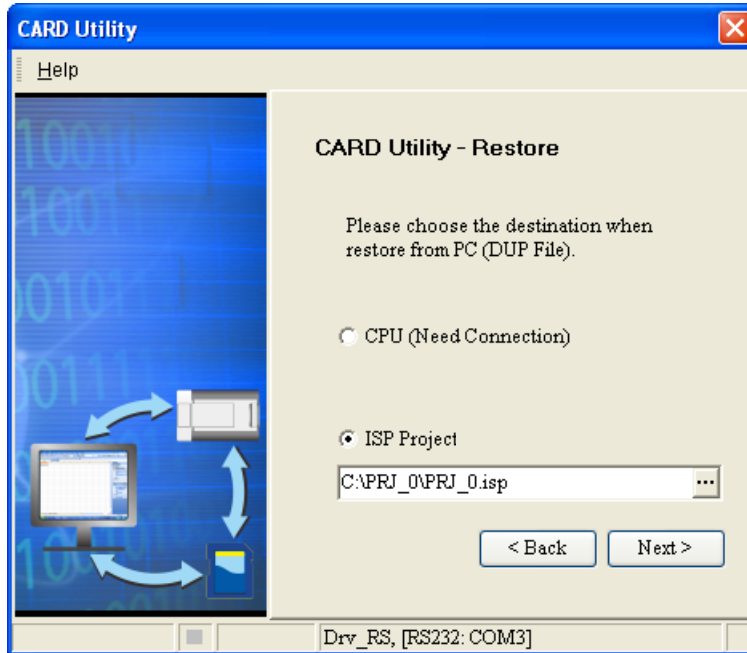

- (4) After you make sure that the summary in the **CARD Utility** window is consistent with the desired data restoration operation, you can click **Execute**.

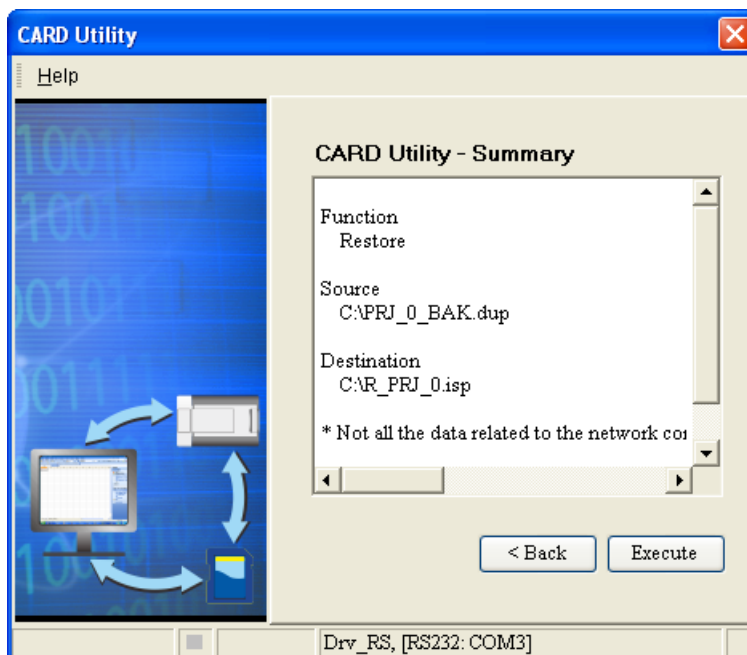

If you click **Cancel** in the process of restoring data to the CPU, the data will not be completely restored. To prevent the CPU from incorrect operation, you have to restore the CPU to the factory setting if you do not perform the data restoration again.

In addition, when you clicked **Cancel** to stop ISPSOft from restoring data from the memory card to the CPU, the CPU will be still in data restoration process. You can power off the CPU to force stop the process.

If restoration source/restoration destination contains a password and an ID, the password and the ID will be processed as follows.

Data restoration	Description
Memory card→CPU	<ul style="list-style-type: none"> <li>a. The ID in the backup file must be the same as the ID in the CPU, otherwise the data restoration will not be performed.</li> <li>b. If there is a PLC password in the CPU, the password in the backup file must be the same as the PLC password in the CPU. Otherwise the data restoration will not be performed.</li> <li>c. If there is no PLC password in the CPU, and there is a password in the backup file, the system will perform the data restoration, and the password in the backup file will become the PLC password in the CPU.</li> </ul>
Computer→CPU	<ul style="list-style-type: none"> <li>a. The ID in the backup file must be the same as the ID in the CPU, otherwise the data restoration will not be performed.</li> <li>b. If there is a PLC password in the CPU, the password in the backup file must be the same as the PLC password in the CPU. Otherwise the data restoration will not be performed, and a message will appear.</li> <li>c. If there is no PLC password in the CPU, and there is a password in the backup file, the system will perform the data restoration, and the password in the backup file will become the PLC password in the CPU.</li> </ul>
Computer→ ISPSoft project	Program ID and the project password remain unchanged in an ISPSoft project.

(5) After the data restoration is performed, you can click **Home** or **Close** in the **CARD Utility** window.

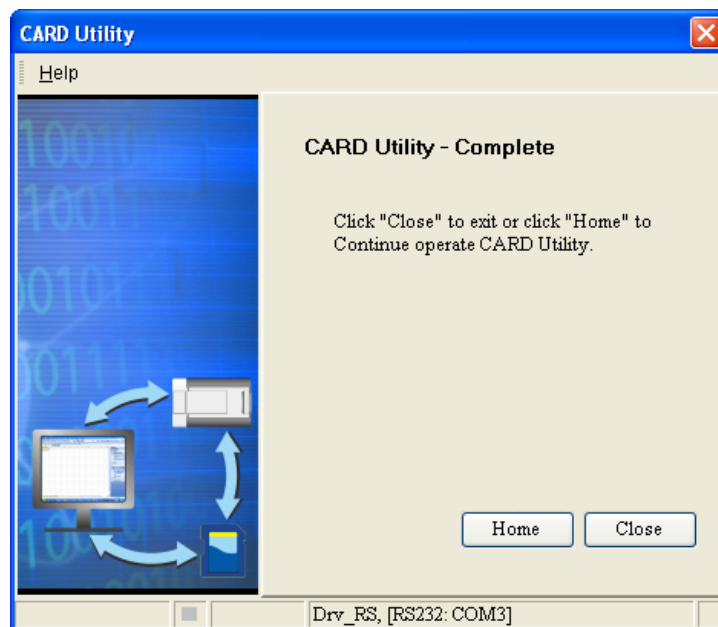

**MEMO**

## Chapter 9 Troubleshooting

### Table of Contents

<b>9.1</b>	<b>Inspection and Troubleshooting</b> .....	<b>9-3</b>
9.1.1	Basic Inspection .....	9-3
9.1.2	Clearing the Error State .....	9-3
9.1.3	Troubleshooting Procedure .....	9-4
9.1.4	Viewing Error Logs .....	9-5
<b>9.2</b>	<b>Error Codes and Indicators</b> .....	<b>9-6</b>
9.2.1.	AHxxEMC-5A .....	9-7
9.2.2.	Analog I/O Modules and Temperature Measurement Modules .....	9-39
9.2.3.	AH02HC-5A/AH04HC-5A .....	9-41
9.2.4.	AH05PM-5A/AH10PM-5A/AH15PM-5A .....	9-41
9.2.5.	AH20MC-5A .....	9-43
9.2.6.	AH10EN-5A/AH15EN-5A .....	9-44
9.2.7.	AH10SCM-5A/AH15SCM-5A .....	9-44
9.2.8.	AH10DNET-5A .....	9-44
9.2.9.	AH10PFBM-5A .....	9-45
9.2.10.	AH10PFBS-5A .....	9-45
9.2.11.	AH10COPM-5A .....	9-46
<b>9.3</b>	<b>Troubleshooting for CPU</b> .....	<b>9-47</b>
9.3.1.	ERROR Indicator ON .....	9-47
9.3.2.	ERROR Indicator Blinking .....	9-49
9.3.3.	BUS FAULT Indicator ON .....	9-92
9.3.4.	BUS FAULT Indicator Blinking .....	9-94
9.3.5.	Others .....	9-102
<b>9.4</b>	<b>Troubleshooting for I/O Modules</b> .....	<b>9-114</b>
9.4.1.	Analog I/O Modules and Temperature Measurement Modules .....	9-114
9.4.2.	AH02HC-5A/AH04HC-5A .....	9-116
9.4.3.	AH05PM-5A/AH10PM-5A/AH15PM-5A .....	9-118
9.4.4.	AH20MC-5A .....	9-121
9.4.5.	AH10EN-5A/AH15EN-5A .....	9-122
9.4.6.	AH10SCM-5A/AH15SCM-5A .....	9-123
9.4.7.	AH10DNET-5A .....	9-123
9.4.8.	AH10PFBM-5A .....	9-124

9.4.9.	AH10PFBS-5A .....	9-125
9.4.10.	AH10COPM-5A .....	9-125
<b>9.5</b>	<b>Troubleshooting for Limitation Errors .....</b>	<b>9-127</b>
9.5.1.	Software limit errors .....	9-127
9.5.2.	Hardware limit errors .....	9-128

## 9.1 Inspection and Troubleshooting

### 9.1.1 Basic Inspection

This chapter describes errors which occur when the system operates, the causes and the corrective actions for the the errors. Before troubleshooting an error, you have to determine the reason and the cause for the error. There are basic inspections which are required to be conducted before you start to determine the reason and cause as below.

- (1) The following items have to be checked.
  - The PLC system must operate under the proper operating conditions specified in the manuals, e.g. the environment specifications, the electrical specifications, the mechanical vibration level, and more.
  - The power is supplied to the equioment or the location where the PLC is installed, and the power supplied to the PLC system is normal.
  - The backplanes, modules, terminals, and cables are installed properly.
  - Every LED indicator is in the normal state.
  - The setting of the switches is correct.
- (2) Follow the instructions below to check the operating state of the AH system.
  - Turn On/Off the RUN/STOP switch.
  - Check the condition for the running/stopping of the CPU.
  - Check and eliminate the influences which could be caused by external devices.
  - Monitor the operating state of the system and the error logs by means of ISPSOft.
- (3) After inspection item (1) and (2) is conducted, you may determine the scope of the reasons that cause the errors as follows:
  - Determine the errors to be caused by AH system, or by external devices.
  - If the error is caused by AH system, you may determine if the error is a CPU error or a module error. Error codes and indicators might need to be checked. Refer to the following sections for details.
  - When the hardware that has errors is identified, you can further confirm if the error are caused by parameter settings or the by the control program.

### 9.1.2 Clearing the Error State

If an error occurs in a system, you can try to clear the error state in the following ways. However, if the cause to the error still exists after the error state is cleared, the error will occur in the system again.

- (1) Turn the RUN/STOP switch on the CPU to STOP, and then turn to RUN.
- (2) Power Off the CPU, and then power On again.
- (3) Clear the error log by means of ISPSOft.
- (4) Reset the CPU or restore the PLC to the factory setting. Download the program again, and execute the program.

### 9.1.3 Troubleshooting Procedure

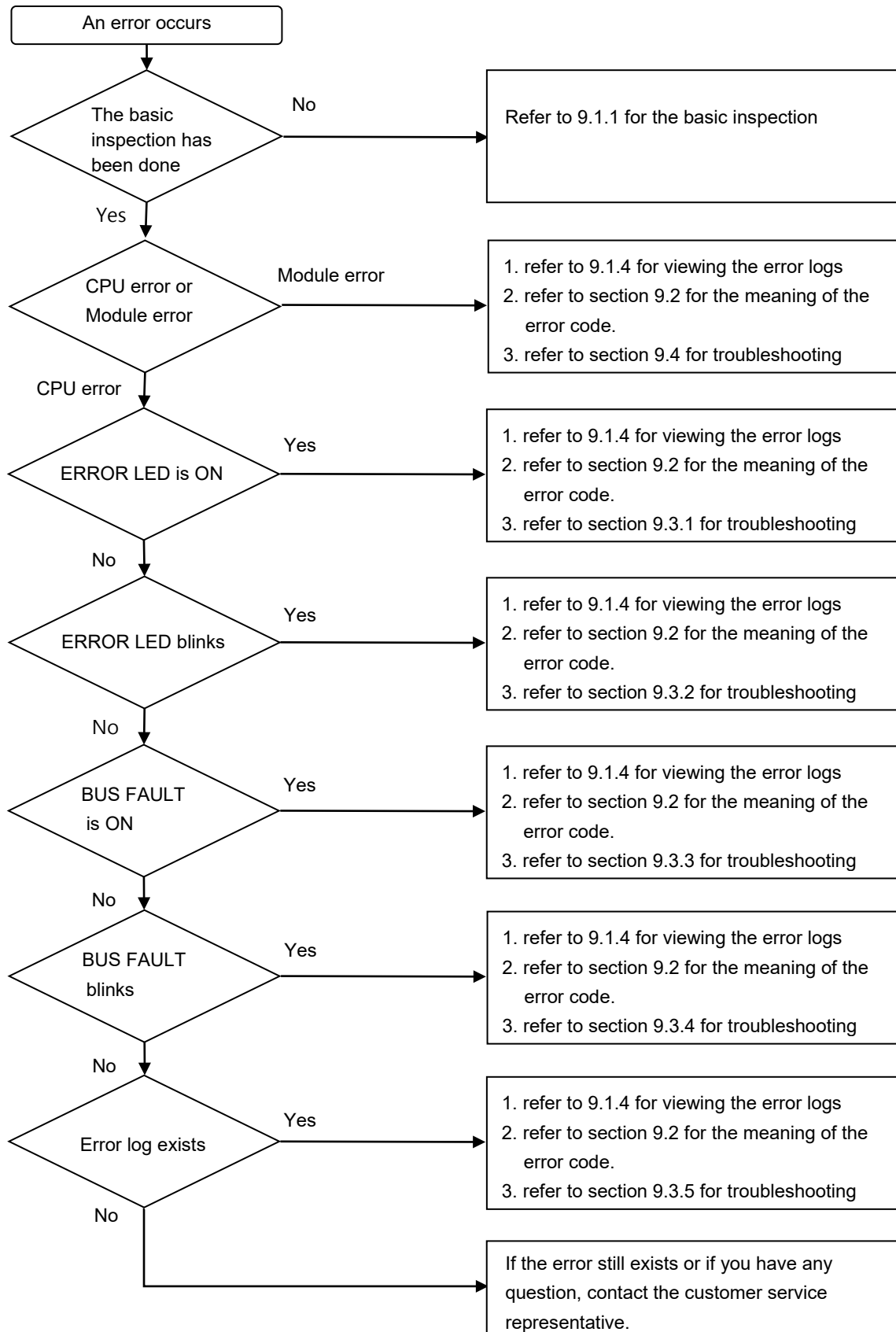

### 9.1.4 Viewing Error Logs

When an error occurs, a corresponding error code generated by a system is recorded in a CPU. Twenty error logs at most can be stored in the CPU. If there are more than twenty error logs generated, the oldest error log will be overwritten by the latest error log. However, if a memory card is installed in the CPU, the twenty error logs are automatically backed up in the memory card before the oldest error log is overwritten. One thousand error logs at most can be stored in the memory card. If there are more than 1000 error logs which will be stored in the memory card, the twenty oldest error logs will be overwritten by the twenty latest error logs.

- (1) After ISPSOft is started, click **System Log** on the **PLC** menu.

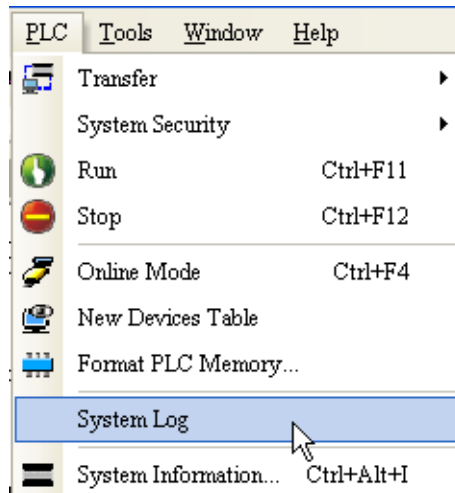

- (2) The **System Log** window is as follows. You can refresh the error logs by clicking **Refresh**, and clear the error logs in the window and the CPU by clicking **Clear Log**.

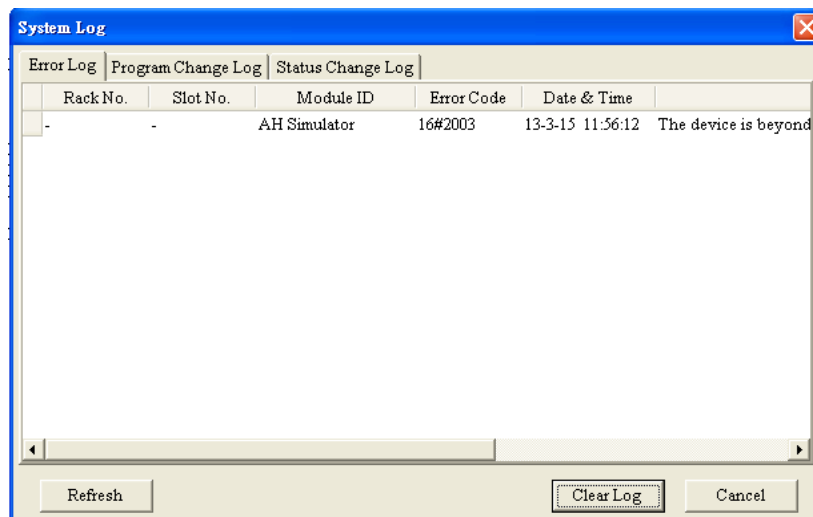

- Rack number & Slot number: If errors are generated by extension modules, the racks and the slots on which the extension modules are installed are recorded in these columns. If no rack number and no slot number are recorded, it means that an error occurs in a CPU module.
- Module ID: The IDs of CPU modules, or those of extension modules
- Error Code: The error code of this error log
- Date & Time: The time when errors occur. The latest error log is displayed in the upper row.
- The simple description related to the error log is in the last field.



## 9.2 Error Codes and Indicators

### ● Columns

Error code <sup>↵</sup>	Description <sup>↵</sup>	CPU Status <sup>↵</sup>	LED indicator status <sup>↵</sup>	
			ERROR <sup>↵</sup>	BUS FAULT <sup>↵</sup>
16#000A <sup>↵</sup>	Scan timeout <sup>↵</sup> (SM8: The watchdog timer error) <sup>↵</sup>	Stop <sup>↵</sup>	Blink <sup>↵</sup>	OFF <sup>↵</sup>
16#000B <sup>↵</sup>	The program in the PLC is damaged. <sup>↵</sup>	Stop <sup>↵</sup>	ON <sup>↵</sup>	OFF <sup>↵</sup>

↓  
**1**

↓  
**2**

↓  
**3**

↓  
**4**

Items provided in the table		
<b>1</b>	<b>Error code</b>	If the error occurs in the system, the error code is generated
<b>2</b>	<b>Description</b>	The description of the error
<b>3</b>	<b>CPU status</b>	If the error occurs, the CPU stops running, keeps running, or in the status defined by users. <b>Stop:</b> The CPU stops running when the error occurs. <b>Keep:</b> The CPU keeps running when the error occurs. <b>Self-defined:</b> The status of the CPU can be defined by users.
<b>4</b>	<b>LED indicator status</b>	LED indicator status: If the error occurs, the LED indicator is ON, OFF, or Blinking. <b>RUN:</b> Operating status of the CPU <b>ERROR:</b> Error status of the CPU <b>BUS FAULT:</b> Error status of the I/O bus <b>SYSTEM:</b> System status of the CPU

### ● LED indicators

The AH Motion Controller CPU can function as a motion CPU or a motion module. The effective LED indicators are different according to the applications of AH Motion Controller CPU, either in CPU mode or in Module mode:

Mode	LED indicator	Description
<b>CPU</b>	RUN	Operating status of the CPU ON: The user program is being executed. OFF: The execution of the user program stops. Blinking: The CPU runs in debug mode.
	ERROR	Error status of the CPU ON: A serious error occurs in the CPU. OFF: The system is normal. Blinking: A slight error occurs in the CPU.
	BUS FAULT	Error status of the I/O bus ON: A serious error occurs in the I/O bus. OFF: The I/O bus is normal. Blinking: A slight error occurs in the I/O bus.

Mode	LED indicator	Description
	SYSTEM	System status of the CPU module ON: The external input/output is forced ON/OFF. OFF: The system is in the default status. Blinking: The CPU module is being reset./The retained values in the devices are being cleared .
Module	RUN	Operating status of the motion CPU functioning as a motion module ON: The user program is being executed. OFF: The execution of the user program stops. Blinking: The motion module runs in debug mode.
	ERROR	Error status of the motion CPU functioning as a motion module ON: A serious error occurs in the module. OFF: The system is normal. Blinking: A slight error occurs in the module.

### 9.2.1. AHxxEMC-5A

After a program is written into an AH Motion Controller series CPU, the ERROR LED indicator will blink and an error flag will be ON if an error occurs in main program or amotion subroutine. The reason for the error occurring in the main program or amotion subroutine may be that the use of operands (devices) is incorrect, syntax is incorrect, or the setting of motion parameters is incorrect. You can know the reasons for the errors occurring in an AH Motion Controller series CPU by means of the error codes (hexadecimal codes) stored in error registers.

#### ■ Error flags and registers:

SM*: Special auxiliary relay SR*: Special data register	Program error	Motion error
	POU	mn=10~41 (10: 1 <sup>st</sup> axis; 41: 32 <sup>nd</sup> axis)
Error flag	-	AMmn49
Operation error	SM0	-
The operation error is locked	SM1	-
Syntax (Instruction/Operand) check error	SM5	-
Operation error code	SR0	-
Operation error address (step)	SR1/SR2	-
Syntax check error code	SR4	ARmn41
Syntax check error address (step)	SR5/SR6	-

## ■ Error codes and indicators

Error code	Description	CPU Status	LED indicator status	
			ERROR	BUS FAULT
16#000A	Scan timeout (SM8: The watchdog timer error)	Stop	Blinking	Keep
16#000B	The program in the PLC is damaged.	Stop	ON	Keep
16#000C	The program downloaded to the PLC is incorrect.	Stop	Blinking	Keep
16#000D	The CPU parameter is damaged.	Stop	ON	Keep
16#000E	The program or the parameter is being downloaded, and therefore the PLC can not run.	Stop	Blinking	Keep
16#000F	The original program in the PLC is damaged.	Continue	Keep	Keep
16#0010	The access to the memory in the CPU is denied.	Stop	ON	Keep
16#0011	The PLC ID is incorrect. (SM9)	Continue	ON	Keep
16#0012	The PLC password is incorrect.	Continue	ON	Keep
16#0013	The I/O module can not run/stop. (SM10)	Stop	Keep	ON
16#0014	The procedure of restoring the system can not be executed. (SM9)	Stop	ON	ON
16#0015	The module table is incorrect. (SM10)	Stop	ON	Keep
16#0016	The module setting is incorrect. (SM10)	Stop	ON	Keep
16#0017	The device which is associated with the data register is incorrect. (SM10)	Stop	ON	Keep
16#0018	The serial port is abnormal. (SM9)	Continue	Blinking	Keep
16#0019	The USB is abnormal. (SM9)	Continue	Blinking	Keep
16#001A	The contents of the system backup file (.dup file) are incorrect.	Continue	Blinking	Keep
16#001B	Timed interrupt 0 is set incorrectly.	Stop	ON	Keep
16#001C	Timed interrupt 1 is set incorrectly.	Stop	ON	Keep
16#001D	Timed interrupt 2 is set incorrectly.	Stop	ON	Keep
16#001E	Timed interrupt 3 is set incorrectly.	Stop	ON	Keep
16#001F	The watchdog timer is set incorrectly.	Stop	ON	Keep
16#0020	The setting of the fixed scan time is incorrect.	Stop	ON	Keep
16#0021	The setting of the fixed scan time is incorrect.	Stop	ON	Keep

Error code	Description	CPU Status	LED indicator status	
			ERROR	BUS FAULT
16#0022	The CPU parameter downloaded to the PLC is incorrect.	Stop	ON	Keep
16#0023	The Y state (STOP->RUN) section in the PLC Parameter Setting window is set incorrectly.	Stop	ON	Keep
16#0024	There is no IO module on the backplane.	Continue	Keep	Keep
16#0025	CPU is lost or reset. (in Module mode only)	As configured	ON	Keep
16#0026	The Communication Ratio box in the Communication Loading of Scan Time (%) section in the PLC Parameter Setting window is set incorrectly.	Stop	ON	Keep
16#0027	The latching auxiliary relay range which is set is incorrect.	Stop	ON	Keep
16#0028	The latching data register range which is set is incorrect.	Stop	ON	Keep
16#0029	The latching timer range which is set is incorrect.	Stop	ON	Keep
16#002A	The latching counter range which is set is incorrect.	Stop	ON	Keep
16#002B	The latching 32-bit counter range which is set is incorrect.	Stop	ON	Keep
16#0033	The communication setting of COM1 is incorrect. (SM9)	Continue	Blinking	Keep
16#0034	The setting of the station address of COM1 is incorrect. (SM9)	Continue	Blinking	Keep
16#0035	The setting of the communication type of COM1 is incorrect. (SM9)	Continue	Blinking	Keep
16#0038	The communication setting of COM2 is incorrect. (SM9)	Continue	Blinking	Keep
16#0039	The setting of the station address of COM2 is incorrect. (SM9)	Continue	Blinking	Keep
16#003A	The setting of the communication type of COM2 is incorrect. (SM9)	Continue	Blinking	Keep
16#0050	The memories in the latched special auxiliary relays are abnormal.	Stop	ON	Keep
16#0051	The latched special data registers are abnormal.	Stop	ON	Keep
16#0052	The memories in the latched auxiliary relays are abnormal.	Stop	ON	Keep
16#0053	The latched timers are abnormal.	Stop	ON	Keep
16#0054	The latched counters are abnormal.	Stop	ON	Keep
16#0055	The latched 32-bit counters are abnormal.	Stop	ON	Keep
16#0056	The memories in the latched timers are abnormal.	Stop	ON	Keep
16#0057	The memories in the latched counters are abnormal.	Stop	ON	Keep

Error code	Description	CPU Status	LED indicator status	
			ERROR	BUS FAULT
16#0058	The memories in the latched 32-bit counters are abnormal.	Stop	ON	Keep
16#0059	The latched data registers are abnormal.	Stop	ON	Keep
16#005A	The latched working registers are abnormal.	Stop	ON	Keep
16#005D	The memory card cannot be detected by the CPU module.	Continue	Blinking	Keep
16#005E	The memory card is initialized incorrectly. (SM453)	Continue	Blinking	Keep
16#005F	The data is read from the inexistent file in the memory card, or the data is written into the inexistent file in the memory card. (SM453)	Continue	Blinking	Keep
16#0061	The capacity of the memory card is not large enough. (SM453)	Continue	Blinking	Keep
16#0062	The memory card is write protected. (SM453)	Continue	Blinking	Keep
16#0063	An error occurs when the data is written into the memory card. (SM453)	Continue	Blinking	Keep
16#0064	The file in the memory card can not be read. (SM453)	Continue	Blinking	Keep
16#0065	The file in the memory card is a read-only file. (SM453)	Continue	Blinking	Keep
16#0066	An error occurs when the system is backed up.	Continue	Blinking	Keep
16#0067	The length of the restored system data exceeds the system data length of CPU module	Continue	Blinking	Keep
16#1400	An error occurs when the data in the controller is accessed.	Stop	Keep	ON
16#1401	An error occurs when the data in the I/O module is accessed. (SM9)	Stop	Keep	ON
16#1402	The actual arrangement of the I/O modules is not consistent with the module table. (SM9)	Stop	Keep	ON
16#1403	An error occurs when the data is read from the module. (SM9)	Stop	Keep	ON
16#1405	The setting parameter of the module is not found. (SM9)	Stop	Keep	ON
16#1407	An error occurs while communicating with the CPU.	Stop	Keep	ON
16#1409	The back panel for extension is disconnected.	Stop	Keep	ON
16#140A	An error occurs while communicating with the extension back panel.	Stop	Keep	ON
16#140B	The number of network modules exceeds the limit. (SM9)	Stop	Keep	ON
16#140C	The checksum of the high-speed data exchange is incorrect.	Stop	Keep	ON

Error code	Description	CPU Status	LED indicator status	
			ERROR	BUS FAULT
16#140D	The ID of the actual power supply module is not the same as the ID of the power supply module set in HWCONFIG. (SM9)	Stop	Keep	ON
16#140E	The amount of data exchanged at a high speed exceeds the maximum amount supported.	Stop	Keep	ON
16#140F	High-speed data exchange error	Stop	Keep	ON
16#1801	There is no interrupt service routine in the CPU module.	Continue	Keep	Keep
16#2000	There is no END in the program in the PLC. (SM5)	Stop	Blinking	Keep
16#2001	The program is incorrect. There is a syntax error.	Stop	Blinking	Keep
16#2002	GOEND is used incorrectly. (SM5)	Stop	Blinking	Keep
16#2003	The devices used in the program exceed the range. (SM0/SM5)	Self-defined	Blinking	Keep
16#2004	The part of the program specified by the label used in CJ/JMP is incorrect, or the label is used repeatedly. (SM0/SM5)	Stop	Blinking	Keep
16#2005	The N value used in MC is not the same as the corresponding N value used in MCR, or the number of N values used in MC is not the same as the number of N values used in MCR. (SM5)	Stop	Blinking	Keep
16#2006	The N values used in MC do not start from 0, or the N values used in MC are not continuous. (SM5)	Stop	Blinking	Keep
16#2007	The operands used in ZRST are not used properly. (SM5)	Stop	Blinking	Keep
16#200A	Invalid instruction (SM5)	Stop	Blinking	Keep
16#200B	The operand n or the other constant operands exceed the range. (SM0/SM5)	Self-defined	Blinking	Keep
16#200C	The operands overlap. (SM0/SM5)	Self-defined	Blinking	Keep
16#200D	An error occurs when the binary number is converted into the binary-coded decimal number. (SM0/SM5)	Self-defined	Blinking	Keep
16#200E	The string does not end with 0x00. (SM0/SM5)	Self-defined	Blinking	Keep
16#200F	The instruction does not support the modification by an index register. (SM5)	Stop	Blinking	Keep
16#2010	1. The instruction does not support the device. 2. Encoding error 3. The instruction is a 16-bit instruction, but the constant operand is a 32-bit code. (SM5)	Stop	Blinking	Keep

Error code	Description	CPU Status	LED indicator status	
			ERROR	BUS FAULT
16#2011	The number of operands is incorrect. (SM5)	Stop	Blinking	Keep
16#2012	Incorrect division operation (SM0/SM5).	Self-defined	Blinking	Keep
16#2013	The value exceeds the range of values which can be represented by the floating-point numbers. (SM0/SM5)	Self-defined	Blinking	Keep
16#2014	The task designated by TKON/TKOFF is incorrect, or exceeds the range. (SM5)	Stop	Blinking	Keep
16#2015	There are more than 32 levels of nested program structures supported by CALL. (SM0)	Self-defined	Blinking	Keep
16#2016	There are more than 32 levels of nested program structures supported by FOR/NEXT. (SM0/SM5)	Self-defined	Blinking	Keep
16#2017	The number of times FOR is used is different from the number of times NEXT is used. (SM5)	Stop	Blinking	Keep
16#2018	There is a label after FEND, but there is no SRET. Or there is SRET, but there is no label. (SM5)	Stop	Blinking	Keep
16#2019	The interrupt task is not after FEND. (SM5)	Stop	Blinking	Keep
16#201A	IRET/SRET is not after FEND. (SM5)	Stop	Blinking	Keep
16#201B	There is an interrupt task, but there is no IRET. There is IRET, but there is not interrupt task. (SM5)	Stop	Blinking	Keep
16#201C	End is not at the end of the program. (SM5)	Stop	Blinking	Keep
16#201D	There is CALL, but there is no MAR. (SM5)	Stop	Blinking	Keep
16#201E	The function code used in MODRW is incorrect. (SM102/SM103)	Self-defined	Blinking	Keep
16#201F	The length of the data set in MODRW is incorrect. (SM102/SM103)	Self-defined	Blinking	Keep
16#2020	The communication command received by using MODRW is incorrect. (SM102/SM103)	Self-defined	Blinking	Keep
16#2021	The checksum of the command received by using MODRW is incorrect. (SM102/SM103)	Self-defined	Blinking	Keep
16#2022	The format of the command used in MODRW does not conform to the ASCII format. (SM102/SM103)	Self-defined	Blinking	Keep
16#2023	There is a communication timeout when MODRW is executed. (SM102/SM103)	Self-defined	Blinking	Keep

Error code	Description	CPU Status	LED indicator status	
			ERROR	BUS FAULT
16#2024	The setting value of the communication timeout is invalid when RS is executed. (SM102/SM103)	Self-defined	Blinking	Keep
16#2025	There is a communication timeout when RS is executed. (SM102/SM103)	Self-defined	Blinking	Keep
16#2026	The interrupt number used in RS is incorrect.	Self-defined	Keep	Keep
16#2027	The execution of FWD is abnormal.	Self-defined	Blinking	Keep
16#2028	The execution of REV is abnormal.	Self-defined	Blinking	Keep
16#2029	The execution of STOP is abnormal.	Self-defined	Blinking	Keep
16#202A	The execution of RSDT is abnormal.	Self-defined	Blinking	Keep
16#202B	The execution of RSTEF is abnormal.	Self-defined	Blinking	Keep
16#202C	I/O interrupt service routine 0 does not exist.	Stop	Blinking	Keep
16#202D	I/O interrupt service routine 1 does not exist.	Stop	Blinking	Keep
16#202E	I/O interrupt service routine 2 does not exist.	Stop	Blinking	Keep
16#202F	I/O interrupt service routine 3 does not exist.	Stop	Blinking	Keep
16#2030	I/O interrupt service routine 4 does not exist.	Stop	Blinking	Keep
16#2031	I/O interrupt service routine 5 does not exist.	Stop	Blinking	Keep
16#2032	I/O interrupt service routine 6 does not exist.	Stop	Blinking	Keep
16#2033	I/O interrupt service routine 7 does not exist.	Stop	Blinking	Keep
16#2034	I/O interrupt service routine 8 does not exist.	Stop	Blinking	Keep
16#2035	I/O interrupt service routine 9 does not exist.	Stop	Blinking	Keep
16#2036	I/O interrupt service routine 10 does not exist.	Stop	Blinking	Keep
16#2037	I/O interrupt service routine 11 does not exist.	Stop	Blinking	Keep
16#2038	I/O interrupt service routine 12 does not exist.	Stop	Blinking	Keep
16#2039	I/O interrupt service routine 13 does not exist.	Stop	Blinking	Keep
16#203A	I/O interrupt service routine 14 does not exist.	Stop	Blinking	Keep
16#203B	I/O interrupt service routine 15 does not exist.	Stop	Blinking	Keep
16#203C	I/O interrupt service routine 16 does not exist.	Stop	Blinking	Keep



Error code	Description	CPU Status	LED indicator status	
			ERROR	BUS FAULT
16#203D	I/O interrupt service routine 17 does not exist.	Stop	Blinking	Keep
16#203E	I/O interrupt service routine 18 does not exist.	Stop	Blinking	Keep
16#203F	I/O interrupt service routine 19 does not exist.	Stop	Blinking	Keep
16#2040	I/O interrupt service routine 20 does not exist.	Stop	Blinking	Keep
16#2041	I/O interrupt service routine 21 does not exist.	Stop	Blinking	Keep
16#2042	I/O interrupt service routine 22 does not exist.	Stop	Blinking	Keep
16#2043	I/O interrupt service routine 23 does not exist.	Stop	Blinking	Keep
16#2044	I/O interrupt service routine 24 does not exist.	Stop	Blinking	Keep
16#2045	I/O interrupt service routine 25 does not exist.	Stop	Blinking	Keep
16#2046	I/O interrupt service routine 26 does not exist.	Stop	Blinking	Keep
16#2047	I/O interrupt service routine 27 does not exist.	Stop	Blinking	Keep
16#2048	I/O interrupt service routine 28 does not exist.	Stop	Blinking	Keep
16#2049	I/O interrupt service routine 29 does not exist.	Stop	Blinking	Keep
16#204A	I/O interrupt service routine 30 does not exist.	Stop	Blinking	Keep
16#204B	I/O interrupt service routine 31 does not exist.	Stop	Blinking	Keep
16#2054   16#2127	External interrupt service routine 40 does not exist.   External interrupt service routine 251 does not exist.	Stop	Blinking	Keep
16#2128	An action in a sequential function chart is incorrectly assigned qualifiers related to time. (Error flag SM0/SM1)	Self-defined	Blinking	Keep
16#2129	The modifier R is assigned to an action in a sequential function chart incorrectly. (Error flag SM0/SM1)	Self-defined	Blinking	Keep
16#3040	Data in the E-CAM exceeds the range or does not exist.	Continue	Blinking	Keep
16#3100	Input parameters exceed the available setting range.	Continue	Blinking	Keep
16#3102	An error occurs in a sub-function block inside the function block.	Continue	Blinking	Keep
16#3103	The distance between the detecting sensors used for identifying exceptional bags is a negative value.	Continue	Blinking	Keep
16#3104	Phasing is executed again before the previous phasing is completed.	Continue	Blinking	Keep

Error code	Description	CPU Status	LED indicator status	
			ERROR	BUS FAULT
16#3105	Superimposing is executed again before the previous superimposing is completed.	Continue	Blinking	Keep
16#3106	Chain position compensation is triggered before the previous compensation is completed.	Continue	Blinking	Keep
16#3107	Film axis position compensation is triggered before the previous compensation is completed.	Continue	Blinking	Keep
16#3108	Knife position compensation is triggered before the previous compensation is completed.	Continue	Blinking	Keep
16#3400	Motion axis number is incorrect.	Continue	Blinking	Keep
16#3401	SDO Data Type setting error (0~199)	Continue	Blinking	Keep
16#3404	The number of the counting channel exceeds the available setting range.	Continue	Blinking	Keep
16#3405	A negative value is given to <i>Velocity</i> .	Continue	Blinking	Keep
16#340A	Homing mode setting error.	Continue	Blinking	Keep
16#340B	Target distance is 0.	Continue	Blinking	Keep
16#340E	Comparison source setting error	Continue	Blinking	Keep
16#3410	User unit setting error; or the output pulse type setting error.	Continue	Blinking	Keep
16#3411	Velocity factor overrides setting error.	Continue	Blinking	Keep
16#3414	Pulse type setting error in DFB_HCnt.	Continue	Blinking	Keep
16#3415	Comparison condition setting error in DFB_Compare.	Continue	Blinking	Keep
16#3419	Master axis position is negative value.	Continue	Blinking	Keep
16#341B	Maximum speed setting error.	Continue	Blinking	Keep
16#3422	The control device chosen for comparison outputs is wrong.	Continue	Blinking	Keep
16#3429	G-code compiling error.	Continue	Blinking	Keep
16#342A	G-code program source error.	Continue	Blinking	Keep
16#342B	G-code ID setting error.	Continue	Blinking	Keep
16#342C	Gcode is in operation.	Continue	Blinking	Keep
16#342D	Gcode grammar is being checked.	Continue	Blinking	Keep
16#342E	The setting of the Gcode Filter is out of the range.	Continue	Blinking	Keep
16#3430	This group number already exists.	Continue	Blinking	Keep

Error code	Description	CPU Status	LED indicator status	
			ERROR	BUS FAULT
16#3431	Motion axis number is repeated in the same group in DFB_GroupEnable.	Continue	Blinking	Keep
16#3432	The specified group number does not exist.	Continue	Blinking	Keep
16#3433	The number of axes is insufficient for the specified group axes motion.	Continue	Blinking	Keep
16#3434	DFB_GroupDisable is executed when group motion is in progress.	Continue	Blinking	Keep
16#3435	Motion axis number is repeated between different groups when DFB_GroupEnable is enabled.	Continue	Blinking	Keep
16#3436	The axis number of the first order should be a positive number other than 0.	Continue	Blinking	Keep
16#3437	The group number exceeds the setting range.	Continue	Blinking	Keep
16#3438	The designated group is in "ErrorStop" state.	Continue	Blinking	Keep
16#343A	Group is executing the function block ImmediateStop.	Continue	Blinking	Keep
16#343B	Errors occur in other axes of the group.	Continue	Blinking	Keep
16#343C	Conditions from GroupEllipse could not be fulfilled.	Continue	Blinking	Keep
16#343D	The state of axis in Group is incorrect.	Continue	Blinking	Keep
16#343E	Use DFB_GroupReset to troubleshoot errors when the axis is in CoordinatedHalt state.	Continue	Blinking	Keep
16#3461	The required communication parameters for PDO settings are not specified.	Continue	Blinking	Keep
16#3463	The designated ECAT Slave does not exist.	Continue	Blinking	Keep
16#3464	PulseRev exceeds the setting range.	Continue	Blinking	Keep
16#3465	DistanceRev exceeds the setting range.	Continue	Blinking	Keep
16#3466	CamCurveType exceeds the setting range.	Continue	Blinking	Keep
16#3467	VelocityEnable exceeds the setting range.	Continue	Blinking	Keep
16#3468	AccelerationEnable exceeds the setting range.	Continue	Blinking	Keep
16#3469	TransitionMode exceeds the setting range.	Continue	Blinking	Keep
16#346A	StopMode exceeds the setting range.	Continue	Blinking	Keep
16#346B	SpiralTurns exceeds the setting range.	Continue	Blinking	Keep
16#346C	IPMode exceeds the setting range.	Continue	Blinking	Keep
16#346D	Position exceeds the setting range.	Continue	Blinking	Keep
16#346E	AuxPosition[0..3] exceeds the setting range.	Continue	Blinking	Keep
16#346F	AuxPosition[4] exceeds the setting range.	Continue	Blinking	Keep
16#3470	DirectionCCW exceeds the setting range.	Continue	Blinking	Keep

Error code	Description	CPU Status	LED indicator status	
			ERROR	BUS FAULT
16#3471	InitialValue exceeds the setting range.	Continue	Blinking	Keep
16#3472	MaskValue exceeds the setting range.	Continue	Blinking	Keep
16#3473	DeltaMin exceeds the setting range.	Continue	Blinking	Keep
16#3474	DeltaMax exceeds the setting range.	Continue	Blinking	Keep
16#3475	DeltaMax<=DeltaMin	Continue	Blinking	Keep
16#3476	LagRatioAcc exceeds the setting range.	Continue	Blinking	Keep
16#3477	LagRatio exceeds the setting range.	Continue	Blinking	Keep
16#3478	Mode exceeds the setting range.	Continue	Blinking	Keep
16#3479	Acceleration exceeds the setting range.	Continue	Blinking	Keep
16#347A	Deceleration exceeds the setting range.	Continue	Blinking	Keep
16#347B	Jerk exceeds the setting range.	Continue	Blinking	Keep
16#347C	ReferenceType exceeds the setting range.	Continue	Blinking	Keep
16#347D	PositiveValue exceeds the setting range.	Continue	Blinking	Keep
16#347E	NegativeValue exceeds the setting range.	Continue	Blinking	Keep
16#347F	Source exceeds the setting range.	Continue	Blinking	Keep
16#3480	RatioDenominator exceeds the setting range.	Continue	Blinking	Keep
16#3481	TriggerInputMode exceeds the setting range.	Continue	Blinking	Keep
16#3482	TriggerInput.TouchProbeID exceeds the setting range.	Continue	Blinking	Keep
16#3500	The axis is not in "Disable" or "Standstill" state. Or the axis is in "Coordinated" state and the axis group is no longer in "Standby".	Continue	Blinking	Keep
16#3501	The selected channel has been used in FB.	Continue	Blinking	Keep
16#3502	It is not allowed to set positions.	Continue	Blinking	Keep
16#3505	An error occurs when writing cam data.	Continue	Blinking	Keep
16#3506	The axis is in "Coordinated" state.	Continue	Blinking	Keep
16#3507	The axis is in "ErrorStop" state.	Continue	Blinking	Keep
16#3508	The axis is not in "StandStill" state.	Continue	Blinking	Keep
16#3509	The axis is in "Stopping" state.	Continue	Blinking	Keep
16#350B	The time to acceleration is too short.	Continue	Blinking	Keep
16#350C	The time to deceleration is too short.	Continue	Blinking	Keep
16#350D	The CAM data length for reading is out of the setting range.	Continue	Blinking	Keep
16#350E	The CAM data length for writing is out of the setting range.	Continue	Blinking	Keep
16#350F	The axis is in "Synchronized" state.	Continue	Blinking	Keep
16#3510	Cam curve linear speed setting error	Continue	Blinking	Keep
16#3511	Cam curve linear acceleration setting error	Continue	Blinking	Keep
16#3512	Cam data does not exist.	Continue	Blinking	Keep

Error code	Description	CPU Status	LED indicator status	
			ERROR	BUS FAULT
16#3513	The position of master axis is set to be less than the previous point.	Continue	Blinking	Keep
16#3514	Cam percentage exceeds the setting range (0~100).	Continue	Blinking	Keep
16#3515	The material length of CamCurve_TMRC exceeds the valid range.	Continue	Blinking	Keep
16#3516	The circumference of CamCurve_TMRC rotary cutting exceeds the valid range.	Continue	Blinking	Keep
16#3517	The number of CamCurve_TMRC rotary cutter exceeds the valid range.	Continue	Blinking	Keep
16#3518	The beginning angle of CamCurve_TMRC sync. zone exceeds the valid range.	Continue	Blinking	Keep
16#3519	The ending angle of CamCurve_TMRC sync. zone exceeds the valid range.	Continue	Blinking	Keep
16#351A	The beginning angle of CamCurve_TMRC sync. zone is greater than the ending angle.	Continue	Blinking	Keep
16#351B	The sync. zone of CamCurve_TMRCrotary is too large.	Continue	Blinking	Keep
16#3522	Flash data is damaged.	Continue	Blinking	Keep
16#3526	The movement error occurs before the axis.	Continue	Blinking	Keep
16#3530	The material length of CamCurve_FRC is 0 or a negative value.	Continue	Blinking	Keep
16#3531	The material length in CamCurve_FRC acceleration zone is a negative value.	Continue	Blinking	Keep
16#3533	The material length in CamCurve_FRC synchronization zone is 0 or a negative value.	Continue	Blinking	Keep
16#3534	The material length in CamCurve_FRC deceleration zone is a negative value.	Continue	Blinking	Keep
16#3536	The material length in CamCurve_FRC jerk zone is a negative value.	Continue	Blinking	Keep
16#3537	Excessive displacement of material in CamCurve_FRC synchronization zone.	Continue	Blinking	Keep
16#3538	Displacement of material in CamCurve_FRC synchronization zone is inadequate.	Continue	Blinking	Keep
16#3539	Material lengths in CamCurve_FRC acceleration and synchronization zone are greater than the total length of the material.	Continue	Blinking	Keep
16#353A	The circumference of CamCurve_FRC cutting is 0 or a negative value.	Continue	Blinking	Keep
16#353B	The cutting length in CamCurve_FRC synchronization zone is a negative value.	Continue	Blinking	Keep
16#353C	Excessive cutting length in CamCurve_FRC synchronization zone.	Continue	Blinking	Keep

Error code	Description	CPU Status	LED indicator status	
			ERROR	BUS FAULT
16#353D	The number of CamCurve_FRC cutter exceeds the valid range.	Continue	Blinking	Keep
16#3540	The material length of CamCurve_FRC_WASAW_sType is a negative value.	Continue	Blinking	Keep
16#3541	The cutting length in CamCurve_FRC_WASAW_sType acceleration zone is 0 or a negative value.	Continue	Blinking	Keep
16#3542	The material length of CamCurve_FRC_WASAW_sType is shorter than the length in synchronization zone.	Continue	Blinking	Keep
16#3543	The material length in CamCurve_FRC_WASAW_sType synchronization zone is 0 or a negative value.	Continue	Blinking	Keep
16#3544	The cutting length in CamCurve_FRC_WASAW_sType deceleration zone is 0 or a negative value.	Continue	Blinking	Keep
16#3546	The cutting length in CamCurve_FRC_WASAW_sType jerk zone is a negative value.	Continue	Blinking	Keep
16#3547	The material length in the forepart of CamCurve_FRC_WASAW_sType unsynchronized section is a negative value.	Continue	Blinking	Keep
16#3548	The material length in the final part of CamCurve_FRC_WASAW_sType unsynchronized section is a negative value.	Continue	Blinking	Keep
16#3549	Material lengths in CamCurve_FRC_WASAW_sType acceleration, deceleration and synchronization zone are longer than the total length of the material.	Continue	Blinking	Keep
16#354A	Cutting lengths in CamCurve_FRC_WASAW_sType acceleration, and synchronization zone are longer than the total circumference of the cutter.	Continue	Blinking	Keep
16#354B	The circumference of CamCurve_FRC_WASAW_sType cutting is 0 or a negative value.	Continue	Blinking	Keep
16#354C	The cutting length in CamCurve_FRC_WASAW_sType synchronization zone is a negative value.	Continue	Blinking	Keep
16#354D	The linear cutting velocity of CamCurve_FRC_WASAW_sType in unsynchronized section is a negative value.	Continue	Blinking	Keep
16#354E	The number of CamCurve_FRC_WASAW_sType cutter exceeds the valid range.	Continue	Blinking	Keep
16#3550	The material length of CamCurve_FRC_SAWAS_sType is a negative value.	Continue	Blinking	Keep
16#3551	The cutting length in CamCurve_FRC_SAWAS_sType acceleration zone is 0 or a negative value.	Continue	Blinking	Keep

Error code	Description	CPU Status	LED indicator status	
			ERROR	BUS FAULT
16#3552	The material length of CamCurve_FRC_SAWAS_sType is shorter than the length in synchronization zone.	Continue	Blinking	Keep
16#3553	The material length in CamCurve_FRC_SAWAS_sType synchronization zone is 0 or a negative value.	Continue	Blinking	Keep
16#3554	The cutting length in CamCurve_FRC_SAWAS_sType deceleration zone is 0 or a negative value.	Continue	Blinking	Keep
16#3556	The cutting length in CamCurve_FRC_SAWAS_sType jerk zone is a negative value.	Continue	Blinking	Keep
16#3557	The material length in the forepart of CamCurve_FRC_SAWAS_sType synchronization zone is a negative value.	Continue	Blinking	Keep
16#3558	The material length in the final part of CamCurve_FRC_SAWAS_sType synchronization zone is a negative value.	Continue	Blinking	Keep
16#3559	Material lengths in CamCurve_FRC_SAWAS_sType acceleration, deceleration and synchronization zone are longer than the total length of the material.	Continue	Blinking	Keep
16#355A	Cutting lengths in CamCurve_FRC_SAWAS_sType acceleration, and synchronization zone are longer than the total circumference of the cutter.	Continue	Blinking	Keep
16#355B	The cutter circumference of CamCurve_FRC_SAWAS_sType is 0 or a negative value.	Continue	Blinking	Keep
16#355C	The cutting length in CamCurve_FRC_SAWAS_sType synchronization zone is a negative value.	Continue	Blinking	Keep
16#355D	The linear cutting velocity of CamCurve_FRC_SAWAS_sType in unsynchronized section is a negative value.	Continue	Blinking	Keep
16#355E	The number of CamCurve_FRC_SAWAS_sType cutter exceeds the valid range.	Continue	Blinking	Keep
16#3600	The state transition is incorrect.	Continue	Blinking	Keep
16#3601	The limit of the number of buffering instructions is reached.	Continue	Blinking	Keep
16#3602	A multiple instructions which are not allowed to be executed at the same time are executed.	Continue	Blinking	Keep
16#3603	Buffermode parameter setting error	Continue	Blinking	Keep
16#3604	Errors occur on the motion direction of the function block	Continue	Blinking	Keep
16#3605	Axis group or single axis motion control function block setting error.	Continue	Blinking	Keep
16#3606	Motion target distance is 0.	Continue	Blinking	Keep

Error code	Description	CPU Status	LED indicator status	
			ERROR	BUS FAULT
16#3607	Target velocity exceeds setting range.	Continue	Blinking	Keep
16#3608	Target velocity exceeds setting range.	Continue	Blinking	Keep
16#3612	It has reached the positive limit.	Continue	Blinking	Keep
16#3613	It has reached the negative limit.	Continue	Blinking	Keep
16#3614	The servo limit is exceeded.	Continue	Blinking	Keep
16#3617	The acceleration exceeds the setting range.	Continue	Blinking	Keep
16#3618	The deceleration exceeds the setting range.	Continue	Blinking	Keep
16#3619	The station address does not exist.	Continue	Blinking	Keep
16#3620	The schedule buffer section of SDO is full.	Continue	Blinking	Keep
16#3622	SDO OD data type is not matched.	Continue	Blinking	Keep
16#3623	SDO is overtime.	Continue	Blinking	Keep
16#3624	SDO data written error	Continue	Blinking	Keep
16#3625	SDO data reading error	Continue	Blinking	Keep
16#3626	SDO retry time exceeds the setting range.	Continue	Blinking	Keep
16#3630	AxisPara setting error.	Continue	Blinking	Keep
16#3631	AxisPara.GearRatioNume / GearRatioDeno unable to set servos.	Continue	Blinking	Keep
16#3632	Axis parameter cannot be modified.	Continue	Blinking	Keep
16#3633	Axis parameter setting error.	Continue	Blinking	Keep
16#3634	AxisPara.SWPosLimit and AxisPara.SWNegLimit setting range error (both parameters are 0, both setting ranges are 0; the range does not include the current instruction position)	Continue	Blinking	Keep
16#3635	AxisPara.RotaryMaxPos and AxisPara.RotaryMinPos setting range error (both parameters are 0, both setting ranges are 0).	Continue	Blinking	Keep
16#3636	The GearRaito cannot be modified when the axis is not Disabled.	Continue	Blinking	Keep
16#3637	The maximum position of rotary axis is out of range.	Continue	Blinking	Keep
16#3638	The minimum position of rotary axis is out of range.	Continue	Blinking	Keep
16#3639	The maximum position of rotary axis is set to be smaller or equal to the minimum position of rotary axis.	Continue	Blinking	Keep
16#3640	After the axis positioning is performed, the actual position of the servo axis could not reach the assigned position within the error margins.	Continue	Blinking	Keep
16#3700	Wrong state transition : Changing the state of a single axis from DiscreteMotion to Homing is not allowed.	Continue	Blinking	Keep
16#3701	Wrong state transition : Changing the state of a single axis from DiscreteMotion to CoordinatedHalt is not allowed.	Continue	Blinking	Keep



Error code	Description	CPU Status	LED indicator status	
			ERROR	BUS FAULT
16#3702	Wrong state transition : Changing the state of a single axis from DiscreteMotion to Coordinated is not allowed.	Continue	Blinking	Keep
16#3703	Wrong state transition : Changing the state of a single axis from DiscreteMotion to CoordinatedStop is not allowed.	Continue	Blinking	Keep
16#3704	Wrong state transition : Changing the state of a single axis from SynchronizedMotion to Homing is not allowed.	Continue	Blinking	Keep
16#3705	Wrong state transition : Changing the state of a single axis from SynchronizedMotion to Standstill is not allowed.	Continue	Blinking	Keep
16#3706	Wrong state transition : Changing the state of a single axis from SynchronizedMotion to CoordinatedHalt is not allowed.	Continue	Blinking	Keep
16#3707	Wrong state transition : Changing the state of a single axis from SynchronizedMotion to Coordinated is not allowed.	Continue	Blinking	Keep
16#3708	Wrong state transition : Changing the state of a single axis from SynchronizedMotion to CoordinatedStop is not allowed.	Continue	Blinking	Keep
16#3709	Wrong state transition : Changing the state of a single axis from ContinuousMotion to Standstill is not allowed.	Continue	Blinking	Keep
16#370A	Wrong state transition : Changing the state of a single axis from ContinuousMotion to CoordinatedHalt is not allowed.	Continue	Blinking	Keep
16#370B	Wrong state transition : Changing the state of a single axis from ContinuousMotion to Coordinated is not allowed.	Continue	Blinking	Keep
16#370C	Wrong state transition : Changing the state of a single axis from ContinuousMotion to CoordinatedStop is not allowed.	Continue	Blinking	Keep
16#370D	Wrong state transition : Changing the state of a single axis from Stopping to DiscreteMotion is not allowed.	Continue	Blinking	Keep
16#370E	Wrong state transition : Changing the state of a single axis from Stopping to SynchronizedMotion is not allowed.	Continue	Blinking	Keep
16#370F	Wrong state transition : Changing the state of a single axis from Stopping to ContinuousMotion is not allowed.	Continue	Blinking	Keep
16#3710	Wrong state transition : Changing the state of a single axis from Stopping to Homing is not allowed.	Continue	Blinking	Keep
16#3711	Wrong state transition : Changing the state of a single axis from Stopping to CoordinatedHalt is not allowed.	Continue	Blinking	Keep
16#3712	Wrong state transition : Changing the state of a single axis from Stopping to Coordinated is not allowed.	Continue	Blinking	Keep
16#3713	Wrong state transition : Changing the state of a single axis from Stopping to CoordinatedStop is not allowed.	Continue	Blinking	Keep

Error code	Description	CPU Status	LED indicator status	
			ERROR	BUS FAULT
16#3714	Wrong state transition : Changing the state of a single axis from Homing to DiscreteMotion is not allowed.	Continue	Blinking	Keep
16#3715	Wrong state transition : Changing the state of a single axis from Homing to SynchronizedMotion is not allowed.	Continue	Blinking	Keep
16#3716	Wrong state transition : Changing the state of a single axis from Homing to ContinuousMotion is not allowed.	Continue	Blinking	Keep
16#3717	Wrong state transition : Changing the state of a single axis from Homing to CoordinatedHalt is not allowed.	Continue	Blinking	Keep
16#3718	Wrong state transition : Changing the state of a single axis from Homing to Coordinated is not allowed.	Continue	Blinking	Keep
16#3719	Wrong state transition : Changing the state of a single axis from Homing to CoordinatedStop is not allowed.	Continue	Blinking	Keep
16#371A	Wrong state transition : Changing the state of a single axis from Standstill to CoordinatedHalt is not allowed.	Continue	Blinking	Keep
16#371B	Wrong state transition : Changing the state of a single axis from Standstill to CoordinatedStop is not allowed.	Continue	Blinking	Keep
16#371C	Wrong state transition : Changing the state of a single axis from Errorstop to DiscreteMotion is not allowed.	Continue	Blinking	Keep
16#371D	Wrong state transition : Changing the state of a single axis from Errorstop to SynchronizedMotion is not allowed.	Continue	Blinking	Keep
16#371E	Wrong state transition : Changing the state of a single axis from Errorstop to ContinuousMotion is not allowed.	Continue	Blinking	Keep
16#371F	Wrong state transition : Changing the state of a single axis from Errorstop to Stopping is not allowed.	Continue	Blinking	Keep
16#3720	Wrong state transition : Changing the state of a single axis from Errorstop to Homing is not allowed.	Continue	Blinking	Keep
16#3721	Wrong state transition : Changing the state of a single axis from Errorstop to CoordinatedHalt is not allowed.	Continue	Blinking	Keep
16#3722	Wrong state transition : Changing the state of a single axis from Errorstop to Coordinated is not allowed.	Continue	Blinking	Keep
16#3723	Wrong state transition : Changing the state of a single axis from Errorstop to CoordinatedStop is not allowed.	Continue	Blinking	Keep
16#3724	Wrong state transition : Changing the state of a single axis from Disabled to DiscreteMotion is not allowed.	Continue	Blinking	Keep
16#3725	Wrong state transition : Changing the state of a single axis from Disabled to SynchronizedMotion is not allowed.	Continue	Blinking	Keep

Error code	Description	CPU Status	LED indicator status	
			ERROR	BUS FAULT
16#3726	Wrong state transition : Changing the state of a single axis from Disabled to ContinuousMotion is not allowed.	Continue	Blinking	Keep
16#3727	Wrong state transition : Changing the state of a single axis from Disabled to Stopping is not allowed.	Continue	Blinking	Keep
16#3728	Wrong state transition : Changing the state of a single axis from Disabled to Homing is not allowed.	Continue	Blinking	Keep
16#3729	Wrong state transition : Changing the state of a single axis from Disabled to CoordinatedHalt is not allowed.	Continue	Blinking	Keep
16#372A	Wrong state transition : Changing the state of a single axis from Disabled to Coordinated is not allowed.	Continue	Blinking	Keep
16#372B	Wrong state transition : Changing the state of a single axis from Disabled to CoordinatedStop is not allowed.	Continue	Blinking	Keep
16#372C	Wrong state transition : Changing the state of a single axis from CoordinatedHalt to DiscreteMotion is not allowed.	Continue	Blinking	Keep
16#372D	Wrong state transition : Changing the state of a single axis from CoordinatedHalt to SynchronizedMotion is not allowed.	Continue	Blinking	Keep
16#372E	Wrong state transition : Changing the state of a single axis from CoordinatedHalt to ContinuousMotion is not allowed.	Continue	Blinking	Keep
16#372F	Wrong state transition : Changing the state of a single axis from CoordinatedHalt to Stopping is not allowed.	Continue	Blinking	Keep
16#3730	Wrong state transition : Changing the state of a single axis from CoordinatedHalt to Homing is not allowed.	Continue	Blinking	Keep
16#3731	Wrong state transition : Changing the state of a single axis from CoordinatedHalt to Standstill is not allowed.	Continue	Blinking	Keep
16#3732	Wrong state transition : Changing the state of a single axis from CoordinatedHalt to Errorstop is not allowed.	Continue	Blinking	Keep
16#3733	Wrong state transition : Changing the state of a single axis from CoordinatedHalt to Disable is not allowed.	Continue	Blinking	Keep
16#3734	Wrong state transition : Changing the state of a single axis from CoordinatedHalt to CoordinatedStop is not allowed.	Continue	Blinking	Keep
16#3735	Wrong state transition : Changing the state of a single axis from Coordinated to DiscreteMotion is not allowed.	Continue	Blinking	Keep
16#3736	Wrong state transition : Changing the state of a single axis from Coordinated to SynchronizedMotion is not allowed.	Continue	Blinking	Keep
16#3737	Wrong state transition : Changing the state of a single axis from Coordinated to ContinuousMotion is not allowed.	Continue	Blinking	Keep

Error code	Description	CPU Status	LED indicator status	
			ERROR	BUS FAULT
16#3738	Wrong state transition : Changing the state of a single axis from Coordinated to Stopping is not allowed.	Continue	Blinking	Keep
16#3739	Wrong state transition : Changing the state of a single axis from Coordinated to Homing is not allowed.	Continue	Blinking	Keep
16#373A	Wrong state transition : Changing the state of a single axis from Coordinated to Errorstop is not allowed.	Continue	Blinking	Keep
16#373B	Wrong state transition : Changing the state of a single axis from Coordinated to Disable is not allowed.	Continue	Blinking	Keep
16#373C	Wrong state transition : Changing the state of a single axis from CoordinatedStop to DiscreteMotion is not allowed.	Continue	Blinking	Keep
16#373D	Wrong state transition : Changing the state of a single axis from CoordinatedStop to SynchronizedMotion is not allowed.	Continue	Blinking	Keep
16#373E	Wrong state transition : Changing the state of a single axis from CoordinatedStop to ContinuousMotion is not allowed.	Continue	Blinking	Keep
16#373F	Wrong state transition : Changing the state of a single axis from CoordinatedStop to Stopping is not allowed.	Continue	Blinking	Keep
16#3740	Wrong state transition : Changing the state of a single axis from CoordinatedStop to Homing is not allowed.	Continue	Blinking	Keep
16#3741	Wrong state transition : Changing the state of a single axis from CoordinatedStop to Standstill is not allowed.	Continue	Blinking	Keep
16#3742	Wrong state transition : Changing the state of a single axis from CoordinatedStop to Errorstop is not allowed.	Continue	Blinking	Keep
16#3743	Wrong state transition : Changing the state of a single axis from CoordinatedStop to Disable is not allowed.	Continue	Blinking	Keep
16#3744	Wrong state transition : Changing the state of a single axis from CoordinatedStop to Homing is not allowed.	Continue	Blinking	Keep
16#3770	Wrong state transition : The axis group state is GroupStopping while executing function blocks concerning linear and rotary movement.	Continue	Blinking	Keep
16#3771	Wrong state transition : Execute two DFB_GroupStop function blocks and StopMode of the second DFB_GroupStop is set to HALT.	Continue	Blinking	Keep
16#3772	Wrong state transition : Execute DFB_GroupStop function blocks and the axis group state is GroupErrorStop.	Continue	Blinking	Keep
16#3773	Wrong state transition : When DFB_GroupStop function block is executed, StopMode is HALT and an error occurs to a single axis in the group.	Continue	Blinking	Keep

Error code	Description	CPU Status	LED indicator status	
			ERROR	BUS FAULT
16#3774	Wrong state transition : When DFB_GroupStop function block is executed, StopMode is STOP and an error occurs to a single axis in the group.	Continue	Blinking	Keep
16#3775	Wrong state transition : When DFB_GroupStop function block is executed, StopMode is HALT and Done is ON. But the axis group state is GroupErrorStop.	Continue	Blinking	Keep
16#3776	Wrong state transition : The axis group state is GroupMoving.	Continue	Blinking	Keep
16#3777	Wrong state transition : When DFB_GroupDisable function block is executed, the axis group state is GroupMoving.	Continue	Blinking	Keep
16#3778	Wrong state transition : When DFB_GroupDisable function block is executed, the axis group state is GroupStopping.	Continue	Blinking	Keep
16#3780	Wrong state transition : The single axis state is not SynchronizedMotion	Continue	Blinking	Keep
16#3781	Wrong state transition : The single axis state is Disabled.	Continue	Blinking	Keep
16#3782	Wrong state transition : The single axis state is neither Standstill nor Homing.	Continue	Blinking	Keep
16#3783	Wrong state transition : The single axis state is Coordinated or CoordinatedHalt.	Continue	Blinking	Keep
16#3784	Wrong state transition : The single axis state is Errorstop.	Continue	Blinking	Keep
16#3800	Motion network disconnected during the execution of the instruction.	Continue	Blinking	Keep
16#3801	Error on EtherCAT axes.	Continue	Blinking	Keep
16#3802	LSP occurs on EtherCAT axes.	Continue	Blinking	Keep
16#3803	LSN occurs on EtherCAT axes.	Continue	Blinking	Keep
16#3901	Failed to re-connect to the motion network.	Continue	Blinking	Keep
16#3904	Motion network master can not read Slave parameters via SDO.	Continue	Blinking	Keep
16#3905	Motion network master can not write Slave parameters via SDO.	Continue	Blinking	Keep
16#3906	Torque limit setting error in MC_SetTorqueLimit	Continue	Blinking	Keep
16#3907	The function is not available for imaginary axes.	Continue	Blinking	Keep
16#3908	The function is not available for encoder axes.	Continue	Blinking	Keep
16#3909	The motion network is currently executing other network functions.	Continue	Blinking	Keep
16#390C	Error occurred on the axis during operation.	Continue	Blinking	Keep
16#390E	Failed to change the state of EtherCAT slave to OP.	Continue	Blinking	Keep

Error code	Description	CPU Status	LED indicator status	
			ERROR	BUS FAULT
16#3910	Disengage when the axes are not in engaging state.	Continue	Blinking	Keep
16#3911	Software limit error	Continue	Blinking	Keep
16#3912	The value in the input contact of the function block exceeds the rotary axis range.	Continue	Blinking	Keep
16#3913	Synchronization for engagement fails	Continue	Blinking	Keep
16#3914	GearInPos velocity is set too small	Continue	Blinking	Keep
16#3915	GearInPos jerk is set too small	Continue	Blinking	Keep
16#3916	GearInPos engagement time is set too small	Continue	Blinking	Keep
16#3917	GearInPos the velocity of the main axis is 0 when the engagement started	Continue	Blinking	Keep
16#3918	The engagement velocity is larger than the AxisVelocityMax	Continue	Blinking	Keep
16#3919	GearInPos the main axis moves in opposite direction	Continue	Blinking	Keep
16#3920	GearInPos the acceleration is set too small.	Continue	Blinking	Keep
16#3921	GearInPosMasterStartDist is out of range.	Continue	Blinking	Keep
16#3922	GearInPos engaging displacement is too small.	Continue	Blinking	Keep
16#3923	GearInPos engaging displacement is too large.	Continue	Blinking	Keep
16#3924	GearInPos the velocity of the main axis starts to change when engaging started.	Continue	Blinking	Keep
16#3950	Capture cannot be used when the pulse speed is beyond 1MHz.	Continue	Blinking	Keep
16#3951	CamCurve wrong input (for example, Concatenate cannot be true or other parameters are out of range.)	Continue	Blinking	Keep
16#3953	Capture uses the same channel number repeatedly.	Continue	Blinking	Keep
16#3954	Torque ramp fail to write	Continue	Blinking	Keep
16#3955	Torque velocity fail to write	Continue	Blinking	Keep
16#3956	The fastest pulse speed of Compare or Capture Source is greater than 1MHz.	Continue	Blinking	Keep
16#3957	The current position is not synchronized with the current position of Compare.	Continue	Blinking	Keep
16#3958	The current position is not synchronized with the current position of Capture.	Continue	Blinking	Keep
16#3959	Delta parameter setting error.	Continue	Blinking	Keep
16#3960	Specific servo or slave devices are not supported.	Continue	Blinking	Keep
16#3961	Specific storage devices are not supported.	Continue	Blinking	Keep
16#3962	DFB_HCnt has not been executed on the master axis.	Continue	Blinking	Keep
16#3A00	CAM table setting error	Continue	Blinking	Keep
16#3A01	CamIn master setting error	Continue	Blinking	Keep

Error code	Description	CPU Status	LED indicator status	
			ERROR	BUS FAULT
16#3A02	CamIn CAM table changed too soon	Continue	Blinking	Keep
16#3A03	CamIn activation mode setting exceeds the available range	Continue	Blinking	Keep
16#3A04	CamIn start mode setting exceeds the available range	Continue	Blinking	Keep
16#3A05	CamIn master scaling is set to 0.0	Continue	Blinking	Keep
16#3A06	CamIn slave scaling is set to 0.0	Continue	Blinking	Keep
16#3A07	CamIn MasterSyncPosition setting error	Continue	Blinking	Keep
16#3A08	CamIn ActivationPosition setting error	Continue	Blinking	Keep
16#3A10	CamIn master start position is set too Small.	Continue	Blinking	Keep
16#3A13	CamIn the velocity is set too small.	Continue	Blinking	Keep
16#3A15	CamIn jerk is set too small.	Continue	Blinking	Keep
16#3A16	CamIn maximum acceleration is set too small	Continue	Blinking	Keep
16#3A17	CamIn Start mode distance is set too small	Continue	Blinking	Keep
16#3A18	CamIn Start mode distance is set too large	Continue	Blinking	Keep
16#3A19	Too many CamIn are wait to start	Continue	Blinking	Keep
16#3A20	Master is moving in the negative direction.	Continue	Blinking	Keep
16#3A21	CamIn is cancelled when it is not in “CamIn” state.	Continue	Blinking	Keep
16#3A30	The limited number of using DFB_SaveCamTable has been reached.	Continue	Blinking	Keep
16#3C00	Flash card is being written.	Continue	Blinking	Keep
16#3D00	EtherCAT ENI file does not match current hardware configuration.	Continue	Blinking	Keep
16#3D01	Slave lost in motion network.	Continue	Blinking	Keep
16#3D03	EtherCAT DC time is set too short. (Shorter than the minimum scan time)	Continue	Blinking	Keep
16#3D05	Servo parameter file does not exist.	As configured	Blinking	Keep
16#3E00	OD : 0x6098 HOMING_METHOD download error	Continue	Blinking	Keep
16#3E01	OD : 0x6099 (subidx : 1) HOMING_SPEEDS (HOMEING_SPEED_DURING_SEARCH_FOR_SWITCH) download error	Continue	Blinking	Keep
16#3E02	OD : 0x6099(subidx : 2) HOMING_SPEEDS (HOMEING_SPEED_DURING_SEARCH_FOR_ZERO) download error	Continue	Blinking	Keep
16#3E03	OD : 0x609A HOMING_ACC download error	Continue	Blinking	Keep
16#3E04	OD : 0x607C HOME_OFFSET download error	Continue	Blinking	Keep
16#3E05	OD : 0x605A QUICK_STOP_OPTION_CODE download error	Continue	Blinking	Keep
16#3E06	OD : 0x6085 QUICK_STOP_DEC download error	Continue	Blinking	Keep

Error code	Description	CPU Status	LED indicator status	
			ERROR	BUS FAULT
16#3E07	OD : 0x6087 TORQUE_SLOPE download error	Continue	Blinking	Keep
16#3E08	OD : 0x6087 TORQUE_SLOPE upload error	Continue	Blinking	Keep
16#3E09	OD : 0x607F MAX_PROFILE_VELOCITY download error	Continue	Blinking	Keep
16#3E0A	OD : 0x607F MAX_PROFILE_VELOCITY upload error	Continue	Blinking	Keep
16#3E0B	OD : 0x2001 ASDA servo panel error code P0-01 upload error	Continue	Blinking	Keep
16#3E0C	OD : 0x603F servo error code upload error	Continue	Blinking	Keep
16#3E0D	OD : 0x212C ASDA electronic gear ratio parameter P1-44 download error	Continue	Blinking	Keep
16#3E0E	OD : 0x212C ASDA electronic gear ratio parameter P1-44 upload error	Continue	Blinking	Keep
16#3E0F	OD : 0x212D ASDA electronic gear ratio parameter P1-45 download error	Continue	Blinking	Keep
16#3E10	OD : 0x212D ASDA electronic gear ratio parameter P1-45 upload error	Continue	Blinking	Keep
16#3E11	OD : 0x230C ASDA latch parameter P3-12 download error	Continue	Blinking	Keep
16#3E12	OD : 0x230C ASDA latch parameter P3-12 upload error	Continue	Blinking	Keep
16#3E13	OD : 0x60E0 POSITIVE_TORQUE_LIMIT_VALUE download error	Continue	Blinking	Keep
16#3E14	OD : 0x60E0 POSITIVE_TORQUE_LIMIT_VALUE upload error	Continue	Blinking	Keep
16#3E15	OD : 0x60E1 NEGATIVE_TORQUE_LIMIT_VALUE download error	Continue	Blinking	Keep
16#3E16	OD : 0x60E1 NEGATIVE_TORQUE_LIMIT_VALUE upload error	Continue	Blinking	Keep
16#3E17	OD : 0x6072 MAX_TORQUE download error	Continue	Blinking	Keep
16#3E18	OD : 0x6072 MAX_TORQUE upload error	Continue	Blinking	Keep
16#4001	An error occurs to the first axis in the module.	Continue	Keep	Blinking
16#4002	An error occurs to the second axis in the module.	Continue	Keep	Blinking
16#4003	An error occurs to the third axis in the module.	Continue	Keep	Blinking
16#4004	An error occurs to the 4th axis in the module.	Continue	Keep	Blinking
16#4005	An error occurs to the 5th axis in the module.	Continue	Keep	Blinking
16#4006	An error occurs to the 6th axis in the module.	Continue	Keep	Blinking
16#4007	An error occurs to the 7th axis in the module.	Continue	Keep	Blinking
16#4008	An error occurs to the 8th axis in the module.	Continue	Keep	Blinking
16#4009	An error occurs to the 9th axis in the module.	Continue	Keep	Blinking
16#400A	An error occurs to the 10th axis in the module.	Continue	Keep	Blinking
16#400B	An error occurs to the 11th axis in the module.	Continue	Keep	Blinking
16#400C	An error occurs to the 12th axis in the module.	Continue	Keep	Blinking
16#400D	An error occurs to the 13th axis in the module.	Continue	Keep	Blinking



Error code	Description	CPU Status	LED indicator status	
			ERROR	BUS FAULT
16#400E	An error occurs to the 14th axis in the module.	Continue	Keep	Blinking
16#400F	An error occurs to the 15th axis in the module.	Continue	Keep	Blinking
16#4010	An error occurs to the 16th axis in the module.	Continue	Keep	Blinking
16#4011	An error occurs to the 17th axis in the module.	Continue	Keep	Blinking
16#4012	An error occurs to the 18th axis in the module.	Continue	Keep	Blinking
16#4013	An error occurs to the 19th axis in the module.	Continue	Keep	Blinking
16#4014	An error occurs to the 20th axis in the module.	Continue	Keep	Blinking
16#4015	An error occurs to the 21st axis in the module.	Continue	Keep	Blinking
16#4016	An error occurs to the 22nd axis in the module.	Continue	Keep	Blinking
16#4017	An error occurs to the 23rd axis in the module.	Continue	Keep	Blinking
16#4018	An error occurs to the 24th axis in the module.	Continue	Keep	Blinking
16#4019	An error occurs to the 25th axis in the module.	Continue	Keep	Blinking
16#401A	An error occurs to the 26th axis in the module.	Continue	Keep	Blinking
16#401B	An error occurs to the 27th axis in the module.	Continue	Keep	Blinking
16#401C	An error occurs to the 28th axis in the module.	Continue	Keep	Blinking
16#401D	An error occurs to the 29th axis in the module.	Continue	Keep	Blinking
16#401E	An error occurs to the 30th axis in the module.	Continue	Keep	Blinking
16#401F	An error occurs to the 31st axis in the module.	Continue	Keep	Blinking
16#4020	An error occurs to the 32nd axis in the module.	Continue	Keep	Blinking
16#4100	An error occurred to the module.	Continue	Keep	Blinking
16#6001	Illegal IP address	Continue	Blinking	Keep
16#6002	Illegal netmask address	Continue	Blinking	Keep
16#6003	Illegal gateway mask	Continue	Blinking	Keep
16#6004	The IP address filter is set incorrectly.	Continue	Blinking	Keep
16#6006	The static ARP table is set incorrectly.	Continue	Blinking	Keep
16#600B	UDP connection failed (error flag SM1091)	Continue	Keep	Keep
16#600C	TCP Socket has been used.(error flag SM1109)	Continue	Keep	Keep
16#600D	The RJ45 port is not connected. (error flag SM1100)	Continue	Keep	Keep
16#600E	The RJ45 port on AH10EN is not connected to the internet.	Continue	Keep	Keep
16#6100	E-mail connection busy (error flag SM1113)	Continue	Keep	Keep
16#6101	Trigger setting error under E-mail sending conditions	Continue	Blinking	Keep
16#6104	E-mail attachment does not exist	Continue	Keep	Keep

Error code	Description	CPU Status	LED indicator status	
			ERROR	BUS FAULT
16#6105	E-mail attachment exceeds the capacity limit	Continue	Keep	Keep
16#6108	Outgoing mail server validation error	Continue	Blinking	Keep
16#6111	The specified E-mail address does not exist.	Continue	Blinking	Keep
16#6200	The remote IP address for TCP socket is not correct.	Continue	Blinking	Keep
16#6201	The local port for TCP socket is not correct.	Continue	Keep	Keep
16#6202	The remote port for TCP socket is not correct.	Continue	Keep	Keep
16#6203	The IP address to send data for TCP socket is not correct.	Continue	Keep	Keep
16#6204	The data length of sending data for TCP socket does not meet the requirement.	Continue	Keep	Keep
16#6205	The data sending device for TCP socket is out of range	Continue	Keep	Keep
16#6206	The IP address to receive data for TCP socket is not correct.	Continue	Keep	Keep
16#6207	The data length of receiving data for TCP socket does not meet the requirement	Continue	Keep	Keep
16#6208	The data receiving device for TCP socket is out of range	Continue	Keep	Keep
16#6209	The remote IP address for UDP socket is not correct.	Continue	Blinking	Keep
16#620A	The local port for UDP socket is not correct.	Continue	Keep	Keep
16#620B	The remote port for UDP socket is not correct.	Continue	Keep	Keep
16#620C	The IP address to send data for UDP socket is not correct.	Continue	Keep	Keep
16#620D	The length of the data which needs to be sent in a UDP Socket Configuration window is illegal.	Continue	Keep	Keep
16#620E	The data sending device for UDP socket is out of range	Continue	Keep	Keep
16#620F	The IP address to receive data for UDP socket is not correct.	Continue	Keep	Keep
16#6210	The data length of receiving data for UDP socket does not meet the requirement	Continue	Keep	Keep
16#6211	The data receiving device for UDP socket is out of range	Continue	Keep	Keep
16#6212	There is no response from the remote device after the timeout period.	Continue	Keep	Keep
16#6213	The data received exceeds the limit.	Continue	Keep	Keep

Error code	Description	CPU Status	LED indicator status	
			ERROR	BUS FAULT
16#6214	The remote device refuses the connection.	Continue	Keep	Keep
16#6215	The current socket connection is closed.	Continue	Keep	Keep
16#6217	The current socket connection has been opened.	Continue	Keep	Keep
16#6218	Data has been sent via the current socket connection.	Continue	Keep	Keep
16#6219	Data has been received via the current socket connection.	Continue	Keep	Keep
16#6300	Ether Link can only be applied to M, D, L devices.	Continue	Blinking	Keep
16#6301	Ether Link device address setting exceeds the valid range.	Continue	Blinking	Keep
16#6302	The data length of Ether Link exceeds the limit.	Continue	Blinking	Keep
16#6303	The remote device connection of Ether Link is terminated.	Continue	Keep	Keep
16#6304	Ether Link connection is busy.	Continue	Keep	Keep
16#6305	Nodes in Ether Link commands is different from the local nodes.	Continue	Blinking	Keep
16#6309	Ether Link response timeout	Continue	Keep	Keep
16#630A	The ID and other settings of the module are different from settings in Ether Link.	Continue	Blinking	Keep
16#630B	Netmask setting of CPU or modules is different from Ether Link settings.	Continue	Blinking	Keep
16#6400	The number of TCP connections reaches the upper limit, or the flag which is related to the sending of the data is not set to ON.	Continue	Keep	Keep
16#6401	The remote device aborts the connection.	Continue	Keep	Keep
16#6402	There is no response from the remote device after the timeout period.	Continue	Keep	Keep
16#6403	The remote IP address used in the applied instruction is illegal.	Continue	Keep	Keep
16#6404	The MODBUS function code not supported is received.	Continue	Keep	Keep
16#6405	The number of data which will be received is not consistent with the actual length of the data.	Continue	Keep	Keep
16#6500	Initialized data exchange error	Continue	Blinking	OFF
16#6501	The remote device involved in the data exchange does not respond after the timeout period. (SM828~SM955)	Continue	OFF	OFF

Error code	Description	CPU Status	LED indicator status	
			ERROR	BUS FAULT
16#6502	The remote device involved in the data exchange does not respond correctly. (SM828~SM955)	Continue	OFF	OFF
16#6600	The network number to receive commands exceeds the valid range.	Continue	Keep	Keep
16#6601	The network is not defined in the network parameters.	Continue	Keep	Keep
16#6602	Node numbers exceed the limit.	Continue	Keep	Keep
16#6603	The device is not defined.	Continue	Keep	Keep
16#6604	There's no available routing to be connected.	Continue	Keep	Keep
16#6605	An unexpected packet has been received.	Continue	Keep	Keep
16#6606	Routing response timeout	Continue	Keep	Keep
16#6700	MODBUS TCP data exchange initialization error	Continue	Keep	Keep
16#6701	MODBUS TCP data exchange timeout	Continue	Keep	Keep
16#6702	MODBUS TCP data receiving error	Continue	Keep	Keep
16#7002	This function is not available for CPU modules.	Continue	Keep	Keep
16#7203	Invalid access code	Continue	Keep	Keep
16#7204	Incorrect CPU module port number	Continue	Keep	Keep
16#7401	Function code error	Continue	Keep	Keep
16#7402	The packet exceeds the max. data length.	Continue	Keep	Keep
16#7407	Non-ASCII characters exist in the command.	Continue	Keep	Keep
16#7408	PLC is in RUN mode	Continue	Keep	Keep
16#740A	The CPU memory is being written or failed to be written.	Continue	Keep	Keep
16#740B	The Clear or Reset operation is in progress.	Continue	Keep	Keep
16#740C	The backplane number in a communication command is incorrect.	Continue	Keep	Keep
16#740D	The slot number in a communication command is incorrect.	Continue	Keep	Keep
16#740E	Error occurs when the memory is being cleared.	Continue	Keep	Keep
16#740F	Communication timeout	Continue	Keep	Keep
16#7410	The function code for responding the instruction is inconsistent.	Continue	Keep	Keep

Error code	Description	CPU Status	LED indicator status	
			ERROR	BUS FAULT
16#7411	The IO module is under execution.	Continue	Keep	Keep
16#7412	Data cannot be downloaded to CPU because SW1 is ON.	Continue	Keep	Keep
16#757D	The number of times users can enter the PLC password is 0.	Continue	Keep	Keep
16#757E	Incorrect PLC password	Continue	Keep	Keep
16#8105	The contents of the program downloaded are incorrect. The program syntax is incorrect.	Continue	Keep	Keep
16#8106	The contents of the program downloaded are incorrect. The length of the execution code exceeds the limit.	Continue	Keep	Keep
16#8107	The contents of the program downloaded are incorrect. The length of the source code exceeds the limit.	Continue	Keep	Keep
16#8114	Failed to backup or restore servo parameters.	Continue	Keep	Keep
16#8230	The CPU parameter downloaded is incorrect. The IP address is illegal.	Continue	Blinking	Keep
16#8231	The CPU parameter downloaded is incorrect. The netmask address is illegal.	Continue	Blinking	Keep
16#8232	The CPU parameter downloaded is incorrect. The gateway address is illegal.	Continue	Blinking	Keep
16#8233	The CPU parameter downloaded is incorrect. The IP address filter is set incorrectly.	Continue	Blinking	Keep
16#8235	The CPU parameter downloaded is incorrect. The static ARP table is set incorrectly.	Continue	Blinking	Keep
16#8236	A CPU parameter downloaded is incorrect. The NTP client service is set incorrectly.	Continue	Keep	Keep
16#8240	A CPU parameter downloaded is incorrect. The data exchange by means of Ethernet is set incorrectly	Continue	Keep	Keep
16#8241	DNS setting error	Continue	Keep	Keep
16#8242	Gcode Data ERROR	Continue	Blinking	Keep
16#8243	ECAM Data ERROR	Continue	Blinking	Keep
16#8244	ENI Data ERROR	Continue	Blinking	Keep
16#8245	EtherCat Data ERROR	Continue	Blinking	Keep
16#8246	Axes Parameters Data ERROR	Continue	Blinking	Keep

Error code	Description	CPU Status	LED indicator status	
			ERROR	BUS FAULT
16#8247	External Gcode Data ERROR	Continue	Blinking	Keep
16#8522	A module configuration is being scanned.	Continue	Keep	Keep
16#853B	An I/O module is not configured.(wirte error)	Continue	Keep	Keep
16#853C	An I/O module does not exist. (wirte error)	Continue	Keep	Keep
16#854B	An I/O module is not configured. (read error)	Continue	Keep	Keep
16#854C	An I/O module does not exist. (read error)	Continue	Keep	Keep
16#8572	The checksum of the module configuration table is incorrect.	Continue	Keep	Keep
16#8576	The checksum of the module parameter setting is incorrect.	Continue	Keep	Keep
16#857A	The checksum of the module parameter mapping table is incorrect.	Continue	Keep	Keep
16#85E1	An I/O interrupt number is incorrect.	Continue	Keep	Keep
16#85E2	An I/O interrupt service routine does not exist.	Continue	Keep	Keep
16#860F	System restoration error	Continue	Keep	Keep
16#8611	No memory card exists, or the memory card format is incorrect.	Continue	Keep	Keep
16#9A33	An error occurs when COM1 communicates with slave 19 by Modbus.	Continue	Keep	Keep
16#9A34	An error occurs when COM1 communicates with slave 20 by Modbus.	Continue	Keep	Keep
16#9A35	An error occurs when COM1 communicates with slave 21 by Modbus.	Continue	Keep	Keep
16#9A47	COM1 receives no response from slave 7 by Modbus.	Continue	Keep	Keep
16#9A61	PLC Link Mode setting error	Continue	Keep	Keep
16#9A62	Current times of PLC LINK polling cycle	Continue	Keep	Keep
16#9A63	There is a handshaking timeout when the CPU module establishes a connection with the network module.	Continue	Keep	Keep
16#9A64	There is no network module parameter in the CPU module.	Continue	Keep	Keep
16#9B01   16#9B20	An error occurs when the Modbus connection of COM2 is initialized.	Continue	Keep	Keep
16#9B21	An error occurs when COM2 communicates with slave 1 by MODBUS.	Continue	Keep	Keep

Error code	Description	CPU Status	LED indicator status	
			ERROR	BUS FAULT
16#9B22	An error occurs when COM2 communicates with slave 2 by MODBUS.	Continue	Keep	Keep
16#9B23	An error occurs when COM2 communicates with slave 3 by MODBUS.	Continue	Keep	Keep
16#9B24	An error occurs when COM2 communicates with slave 4 by MODBUS.	Continue	Keep	Keep
16#9B25	An error occurs when COM2 communicates with slave 5 by MODBUS.	Continue	Keep	Keep
16#9B26	An error occurs when COM2 communicates with slave 6 by MODBUS.	Continue	Keep	Keep
16#9B27	An error occurs when COM2 communicates with slave 7 by MODBUS.	Continue	Keep	Keep
16#9B28	An error occurs when COM2 communicates with slave 8 by MODBUS.	Continue	Keep	Keep
16#9B29	An error occurs when COM2 communicates with slave 9 by MODBUS.	Continue	Keep	Keep
16#9B2A	An error occurs when COM2 communicates with slave 10 by MODBUS.	Continue	Keep	Keep
16#9B2B	An error occurs when COM2 communicates with slave 11 by MODBUS.	Continue	Keep	Keep
16#9B2C	An error occurs when COM2 communicates with slave 12 by MODBUS.	Continue	Keep	Keep
16#9B2D	An error occurs when COM2 communicates with slave 13 by MODBUS.	Continue	Keep	Keep
16#9B2E	An error occurs when COM2 communicates with slave 14 by MODBUS.	Continue	Keep	Keep
16#9B2F	An error occurs when COM2 communicates with slave 15 by MODBUS.	Continue	Keep	Keep
16#9B30	An error occurs when COM2 communicates with slave 16 by MODBUS.	Continue	Keep	Keep
16#9B31	An error occurs when COM2 communicates with slave 17 by MODBUS.	Continue	Keep	Keep

Error code	Description	CPU Status	LED indicator status	
			ERROR	BUS FAULT
16#9B32	An error occurs when COM2 communicates with slave 18 by MODBUS.	Continue	Keep	Keep
16#9B33	An error occurs when COM2 communicates with slave 19 by MODBUS.	Continue	Keep	Keep
16#9B34	An error occurs when COM2 communicates with slave 20 by MODBUS.	Continue	Keep	Keep
16#9B35	An error occurs when COM2 communicates with slave 21 by MODBUS.	Continue	Keep	Keep
16#9B36	An error occurs when COM2 communicates with slave 22 by MODBUS.	Continue	Keep	Keep
16#9B37	An error occurs when COM2 communicates with slave 23 by MODBUS.	Continue	Keep	Keep
16#9B38	An error occurs when COM2 communicates with slave 24 by MODBUS.	Continue	Keep	Keep
16#9B39	An error occurs when COM2 communicates with slave 25 by MODBUS.	Continue	Keep	Keep
16#9B3A	An error occurs when COM2 communicates with slave 26 by MODBUS.	Continue	Keep	Keep
16#9B3B	An error occurs when COM2 communicates with slave 27 by MODBUS.	Continue	Keep	Keep
16#9B3C	An error occurs when COM2 communicates with slave 28 by MODBUS.	Continue	Keep	Keep
16#9B3D	An error occurs when COM2 communicates with slave 29 by MODBUS.	Continue	Keep	Keep
16#9B3E	An error occurs when COM2 communicates with slave 30 by MODBUS.	Continue	Keep	Keep
16#9B3F	An error occurs when COM2 communicates with slave 31 by MODBUS.	Continue	Keep	Keep
16#9B40	An error occurs when COM2 communicates with slave 32 by MODBUS.	Continue	Keep	Keep
16#9B41	COM2 receives no response from slave 1 by MODBUS.	Continue	Keep	Keep
16#9B42	COM2 receives no response from slave 2 by MODBUS.	Continue	Keep	Keep



Error code	Description	CPU Status	LED indicator status	
			ERROR	BUS FAULT
16#9B43	COM2 receives no response from slave 3 by MODBUS.	Continue	Keep	Keep
16#9B44	COM2 receives no response from slave 4 by MODBUS.	Continue	Keep	Keep
16#9B45	COM2 receives no response from slave 5 by MODBUS.	Continue	Keep	Keep
16#9B46	COM2 receives no response from slave 6 by MODBUS.	Continue	Keep	Keep
16#9B47	COM2 receives no response from slave 7 by MODBUS.	Continue	Keep	Keep
16#9B48	COM2 receives no response from slave 8 by MODBUS.	Continue	Keep	Keep
16#9B49	COM2 receives no response from slave 9 by MODBUS.	Continue	Keep	Keep
16#9B4A	COM2 receives no response from slave 10 by MODBUS.	Continue	Keep	Keep
16#9B4B	COM2 receives no response from slave 11 by MODBUS.	Continue	Keep	Keep
16#9B4C	COM2 receives no response from slave 12 by MODBUS.	Continue	Keep	Keep
16#9B4D	COM2 receives no response from slave 13 by MODBUS.	Continue	Keep	Keep
16#9B4E	COM2 receives no response from slave 14 by MODBUS.	Continue	Keep	Keep
16#9B4F	COM2 receives no response from slave 15 by MODBUS.	Continue	Keep	Keep
16#9B50	COM2 receives no response from slave 16 by MODBUS.	Continue	Keep	Keep
16#9B51	COM2 receives no response from slave 17 by MODBUS.	Continue	Keep	Keep
16#9B52	COM2 receives no response from slave 18 by MODBUS.	Continue	Keep	Keep
16#9B53	COM2 receives no response from slave 19 by MODBUS.	Continue	Keep	Keep
16#9B54	COM2 receives no response from slave 20 by MODBUS.	Continue	Keep	Keep
16#9B55	COM2 receives no response from slave 21 by MODBUS.	Continue	Keep	Keep
16#9B56	COM2 receives no response from slave 22 by MODBUS.	Continue	Keep	Keep
16#9B57	COM2 receives no response from slave 23 by MODBUS.	Continue	Keep	Keep
16#9B58	COM2 receives no response from slave 24 by MODBUS.	Continue	Keep	Keep
16#9B59	COM2 receives no response from slave 25 by MODBUS.	Continue	Keep	Keep
16#9B5A	COM2 receives no response from slave 26 by MODBUS.	Continue	Keep	Keep
16#9B5B	COM2 receives no response from slave 27 by MODBUS.	Continue	Keep	Keep
16#9B5C	COM2 receives no response from slave 28 by MODBUS.	Continue	Keep	Keep
16#9B5D	COM2 receives no response from slave 29 by MODBUS.	Continue	Keep	Keep

Error code	Description	CPU Status	LED indicator status	
			ERROR	BUS FAULT
16#9B5E	COM2 receives no response from slave 30 by MODBUS.	Continue	Keep	Keep
16#9B5F	COM2 receives no response from slave 31 by MODBUS.	Continue	Keep	Keep
16#9B60	COM2 receives no response from slave 32 by MODBUS.	Continue	Keep	Keep
16#A010	The module is in RUN state while receiving data from the PLC.	Stop	Keep	ON
16#A402	Miscompare LRC when the PLC sends data to the module.	Stop	Keep	ON
16#A801	The PLC sends data to the module with incorrect function codes.	Stop	Keep	ON
16#A803	The PLC sends data to the module with incorrect commands of function codes.	Stop	Keep	ON
16#A805	The length of data sent from the PLC exceeds the limit.	Stop	Keep	ON
16#A808	Module data read errors occur while the PLC sending data to the module.	Stop	Keep	ON

### 9.2.2. Analog I/O Modules and Temperature Measurement Modules

Error code	Description	LED indicator status	
		CPU	Module
		BUS FAULT	ERROR
16#A000	The signal received by channel 0 exceeds the range of inputs which can be received by the hardware.	Blinking	
16#A001	The signal received by channel 1 exceeds the range of inputs which can be received by the hardware.	Blinking	
16#A002	The signal received by channel 2 exceeds the range of inputs which can be received by the hardware.	Blinking	
16#A003	The signal received by channel 3 exceeds the range of inputs which can be received by the hardware.	Blinking	
16#A004	The signal received by channel 4 exceeds the range of inputs which can be received by the hardware.	Blinking	
16#A005	The signal received by channel 5 exceeds the range of inputs which can be received by the hardware.	Blinking	
16#A006	The signal received by channel 6 exceeds the range of inputs which can be received by the hardware.	Blinking	
16#A007	The signal received by channel 7 exceeds the range of inputs which can be received by the hardware.	Blinking	
16#A400	The signal received by channel 0 exceeds the range of inputs which can be received by the hardware.	ON	

Error code	Description	LED indicator status	
		CPU	Module
		BUS FAULT	ERROR
16#A401	The signal received by channel 1 exceeds the range of inputs which can be received by the hardware.	ON	
16#A402	The signal received by channel 2 exceeds the range of inputs which can be received by the hardware.	ON	
16#A403	The signal received by channel 3 exceeds the range of inputs which can be received by the hardware.	ON	
16#A404	The signal received by channel 4 exceeds the range of inputs which can be received by the hardware.	ON	
16#A405	The signal received by channel 5 exceeds the range of inputs which can be received by the hardware.	ON	
16#A406	The signal received by channel 6 exceeds the range of inputs which can be received by the hardware.	ON	
16#A407	The signal received by channel 7 exceeds the range of inputs which can be received by the hardware.	ON	
16#A600	Hardware failure	ON	
16#A601	The external voltage is abnormal.	ON	
16#A602	Internal error The CJC is abnormal.	ON	
16#A603	Internal error The factory correction is abnormal.	ON	
16#A800	The signal received by channel 0 exceeds the range of inputs which can be received by the hardware.	OFF	
16#A801	The signal received by channel 1 exceeds the range of inputs which can be received by the hardware.	OFF	
16#A802	The signal received by channel 2 exceeds the range of inputs which can be received by the hardware.	OFF	
16#A803	The signal received by channel 3 exceeds the range of inputs which can be received by the hardware.	OFF	
16#A804	The signal received by channel 4 exceeds the range of inputs which can be received by the hardware.	OFF	
16#A805	The signal received by channel 5 exceeds the range of inputs which can be received by the hardware.	OFF	
16#A806	The signal received by channel 6 exceeds the range of inputs which can be received by the hardware.	OFF	
16#A807	The signal received by channel 7 exceeds the range of inputs which can be received by the hardware.	OFF	

\*With regard to the errors related to the input signals' exceeding the range of inputs which can be received by the hardware and the conversion values' exceeding the limits, whether the error code generated is within the range between 16#A000 and 16#A00F, within the range between 16#A400 and 16#A40F, or within the range between 16#A800~16#A80F depends on the LED indicator status defined by users.

### 9.2.3. AH02HC-5A/AH04HC-5A

Error code	Description	LED indicator status	
		CPU	Module
		BUS FAULT	ERROR
16#A001	The linear accumulation in channel 0 exceeds the range.		Blinking
16#A002	The scale set for channel 0 exceeds the range.		Blinking
16#A003	The number of cycles set for channel 0 exceeds the range.		Blinking
16#A004	The comparison value set for channel 0 exceeds the range.		Blinking
16#A005	A limit value set for channel 0 is incorrect.		Blinking
16#A006	The interrupt number set for channel 0 exceeds the range.		Blinking
16#A011	The linear accumulation in channel 1 exceeds the range.		Blinking
16#A012	The scale set for channel 1 exceeds the range.		Blinking
16#A013	The number of cycles set for channel 1 exceeds the range.		Blinking
16#A014	The comparison value set for channel 1 exceeds the range.		Blinking
16#A015	A limit value set for channel 1 is incorrect.		Blinking
16#A016	The interrupt number set for channel 1 exceeds the range.		Blinking
16#A021	The linear accumulation in channel 2 exceeds the range.		Blinking
16#A022	The scale set for channel 2 exceeds the range.		Blinking
16#A023	The number of cycles set for channel 2 exceeds the range.		Blinking
16#A024	The comparison value set for channel 2 exceeds the range.		Blinking
16#A025	A limit value set for channel 2 is incorrect.		Blinking
16#A026	The interrupt number set for channel 2 exceeds the range.		Blinking
16#A031	The linear accumulation in channel 3 exceeds the range.		Blinking
16#A032	The scale set for channel 3 exceeds the range.		Blinking
16#A033	The number of cycles set for channel 3 exceeds the range.		Blinking
16#A034	The comparison value set for channel 3 exceeds the range.		Blinking
16#A035	A limit value set for channel 3 is incorrect.		Blinking
16#A036	The interrupt number set for channel 3 exceeds the range.		Blinking

### 9.2.4. AH05PM-5A/AH10PM-5A/AH15PM-5A

Error code	Description	LED indicator status	
		CPU	Module
		BUS FAULT	Error
16#A002	The subroutine has no data.		Blinking
16#A003	CJ, CJN, and JMP have no matching pointers.		Blinking
16#A004	There is a subroutine pointer in the main program.		Blinking
16#A005	Lack of the subroutine		Blinking
16#A006	The pointer is used repeatedly in the same program.		Blinking
16#A007	The subroutine pointer is used repeatedly.		Blinking
16#A008	The pointer used in JMP is used repeatedly in different subroutines.		Blinking

Error code	Description	LED indicator status	
		CPU	Module
		BUS FAULT	Error
16#A009	The pointer used in JMP is the same as the pointer used in CALL.	Blinking	
16#A00A	The pointer used in JMP is the same as a subroutine pointer.	Blinking	
16#A00B	Target position (I) of the single speed is incorrect.	Blinking	
16#A00C	Target position (II) of the single-axis motion is incorrect.	Blinking	
16#A00D	The setting of speed (I) of the single-axis motion is incorrect.	Blinking	
16#A00E	The setting of speed (II) of the single-axis motion is incorrect.	Blinking	
16#A00F	The setting of the speed ( $V_{RT}$ ) of returning to zero is incorrect.	Blinking	
16#A010	The setting of the deceleration ( $V_{CR}$ ) of returning to zero is incorrect.	Blinking	
16#A011	The setting of the JOG speed is incorrect.	Blinking	
16#A012	The positive pulses generated by the single-axis clockwise motion are inhibited.	Blinking	
16#A013	The negative pulses generated by the single-axis counterclockwise motion are inhibited.	Blinking	
16#A014	The limit switch is reached.	Blinking	
16#A015	The device which is used exceeds the device range.	Blinking	
16#A017	An error occurs when the device is modified by a 16-bit index register/32-bit index register.	Blinking	
16#A018	The conversion into the floating-point number is incorrect.	Blinking	
16#A019	The conversion into the binary-coded decimal number is incorrect.	Blinking	
16#A01A	Incorrect division operation (The divisor is 0.)	Blinking	
16#A01B	General program error	Blinking	
16#A01C	LD/LDI has been used more than nine times.	Blinking	
16#A01D	There is more than one level of nested program structure supported by RPT/RPE.	Blinking	
16#A01E	SRET is used between RPT and RPE.	Blinking	
16#A01F	There is no M102 in the main program, or there is no M2 in the motion program.	Blinking	
16#A020	The wrong instruction is used, or the device used exceeds the range.	Blinking	

### 9.2.5. AH20MC-5A

Error code	Description	LED indicator status	
		CPU	Module
		BUS FAULT	ERROR
16#A002	The subroutine has no data.	Blinking	
16#A003	CJ, CJK, and JMP have no matching pointers.	Blinking	
16#A004	There is a subroutine pointer in the main program.	Blinking	
16#A005	Lack of the subroutine	Blinking	
16#A006	The pointer is used repeatedly in the same program.	Blinking	
16#A007	The subroutine pointer is used repeatedly.	Blinking	
16#A008	The pointer used in JMP is used repeatedly in different subroutines.	Blinking	
16#A009	The pointer used in JMP is the same as the pointer used in CALL.	Blinking	
16#A00B	Target position (I) of the single speed is incorrect.	Blinking	
16#A00C	Target position (II) of the single-axis motion is incorrect.	Blinking	
16#A00D	The setting of speed (I) of the single-axis motion is incorrect.	Blinking	
16#A00E	The setting of speed (II) of the single-axis motion is incorrect.	Blinking	
16#A00F	The setting of the speed (V <sub>RT</sub> ) of returning to zero is incorrect.	Blinking	
16#A010	The setting of the deceleration (V <sub>CR</sub> ) of returning to zero is incorrect.	Blinking	
16#A011	The setting of the JOG speed is incorrect.	Blinking	
16#A012	The positive pulses generated by the single-axis clockwise motion are inhibited.	Blinking	
16#A013	The negative pulses generated by the single-axis counterclockwise motion are inhibited.	Blinking	
16#A014	The limit switch is reached.	Blinking	
16#A015	The device which is used exceeds the device range.	Blinking	
16#A017	An error occurs when the device is modified by a 16-bit index register/32-bit index register.	Blinking	
16#A018	The conversion into the floating-point number is incorrect.	Blinking	
16#A019	The conversion into the binary-coded decimal number is incorrect.	Blinking	
16#A01A	Incorrect division operation (The divisor is 0.)	Blinking	
16#A01B	General program error	Blinking	
16#A01C	LD/LDI has been used more than nine times.	Blinking	
16#A01D	There is more than one level of nested program structure supported by RPT/RPE.	Blinking	
16#A01E	SRET is used between RPT and RPE.	Blinking	
16#A01F	Incorrect division operation (The divisor is 0.)	Blinking	
16#A020	The wrong instruction is used, or the device used exceeds the range.	Blinking	

### 9.2.6. AH10EN-5A/AH15EN-5A

Error code	Description	LED indicator status	
		CPU	Module
		BUS FAULT	Error
16#A001	The IP address of host 1 conflicts with another system on the network.	Blinking	
16#A002	The IP address of host 2 conflicts with another system on the network.	Blinking	
16#A003	DHCP for host 1 fails.	Blinking	
16#A004	DHCP for host 2 fails.	Blinking	
16#A401	Hardware error	ON	
16#A402	The initialization of the system fails.	ON	

### 9.2.7. AH10SCM-5A/AH15SCM-5A

Error code	Description	LED indicator status	
		CPU	Module
		BUS FAULT	ERROR
16#A002	The setting of the UD Link is incorrect, or the communication fails.	Blinking	
16#A401	Hardware error	ON	
16#A804	The communication through the communication port is incorrect.	OFF	
16#A808	MODBUS communication error	OFF	

### 9.2.8. AH10DNET-5A

Error code	Description	LED indicator status		
		CPU	Module	
		BUS FAULT	MS	NS
16#A0F0	The node ID of AH10DNET-5A is the same as other node ID on the network, or exceeds the range.	The red light blinks.	The green light blinks.	The red light is ON.
16#A0F1	No slave is put on the scan list of AH10DNET-5A.	The red light blinks.	The green light blinks.	The green light is ON.
16#A0F2	The working voltage of AH10DNET-5A is low.	The red light blinks.	The red light blinks.	The red light blinks.
16#A0F3	AH10DNET-5A enters the test mode.	The red light blinks.	The orange light is ON.	The orange light is ON.
16#A0F4	The bus of AH10DNET-5A is switched OFF.	The red light blinks.	The green light is ON.	The red light is ON.
16#A0F5	AH10DNET-5A detects that there is no network power supply to the DeviceNet.	The red light blinks.	The red light blinks.	The red light is ON.
16#A0F6	Something is wrong with the internal memory of AH10DNET-5A.	The red light blinks.	The red light is ON.	The green light blinks.
16#A0F7	Something is wrong with the data exchange unit of AH10DNET-5A.	The red light blinks.	The red light is ON.	The green light blinks.
16#A0F8	The product ID of AH10DNET-5A is incorrect.	The red light blinks.	The red light is ON.	The green light blinks.
16#A0F9	An error occurs when the data is read from AH10DNET-5A, or when the data is written into AH10DNET-5A.	The red light blinks.	The red light is ON.	The red light is ON.
16#A0FA	The node ID of AH10DNET-5A is the same as that of the slave set in the scan list.	The red light blinks.	The green light is ON.	The red light is ON.

Error code	Description	LED indicator status		
		CPU	Module	
		BUS FAULT	MS	NS
16#A0FB	The data exchange between AH10DNET and AH CPU failed.	The red light blinks.	The green light is ON.	The green light is ON.
16#A0FC	Errors occur in the slaves, on the module of an AHRTU-DNET backplane, or on the AHRTU-DNET backplane connection.	The red light blinks.	The red light blinks.	The green light is ON.

### 9.2.9. AH10PFBM-5A

Error code	Description	LED indicator status			
		CPU		MODULE	
		BUS FAULT	RUN	SYS	DP
16#A001	The master is not set.	The red light blinks.	The green light is ON.	The green light is ON.	The green light blinks.
16#A003	The master station enters the test mode.	The red light blinks.	The green light is ON.	The green light is ON.	The green light is ON.
16#A005	A timeout occurs when chips inside the master station communicate.	The red light blinks.	The green light is ON.	The green light is ON.	The green light is ON.
16#A00B	A timeout occurs when AH10PFBM-5A exchanges data exchange with a PLC.	The red light blinks.	The green light is ON.	The green light is ON.	The green light is ON.
16#A402	The PLC does not assign the I/O mapping area to the master.	The red light is ON.	The green light is ON.	The green light is ON.	The green light is ON.
16#A404	Master initializing error	The red light is ON.	The green light is ON.	The green light is ON.	The green light is ON.
16#A406	Internal storage unit error	The red light is ON.	The green light is ON.	The green light is ON.	The green light is ON.
16#A407	Data exchange unit error	The red light is ON.	The green light is ON.	The green light is ON.	The green light is ON.
16#A408	Master serial number detection error	The red light is ON.	The green light is ON.	The green light is ON.	The green light is ON.
16#A4E2	The master detects that all the slaves are offline.	The red light is ON.	OFF	The green light is ON.	The red light is ON.
	The master detects that some of the slaves are offline.	The red light is ON.	OFF	The green light is ON.	The red light blinks.
16#A4E6	The master detects that an error occurs in the module connected to AHRTU-PFBS-5A.	The red light is ON.	The green light is ON.	The green light is ON.	The green light is ON.

### 9.2.10. AH10PFBS-5A

Error code	Description	LED indicator status		
		CPU	MODULE	
		BUS FAULT	RUN	NET
16#A4F0	The node address of AH10PFBS-5A exceeds the valid range.	The red light is ON.	The green light is ON.	The green light is ON.
16#A4F1	Internal hardware error	The red light is ON.	The green light is ON.	The green light is ON.
16#A4F2	Parameter error	The red light is ON.	The green light is ON.	The green light is ON.
16#A4F3	Configuration error	The red light is ON.	The green light is ON.	The green light is ON.
16#A4F4	GPIO detection error	The red light is ON.	The green light is ON.	The green light is ON.
16#A4F5	AH10PFBS-5A enters the mode of factory test.	The red light is ON.	The green light is ON.	The green light is ON.



Error code	Description	LED indicator status		
		CPU	MODULE	
		BUS FAULT	RUN	NET
16#A4F6	1. AH10PFBS-5A has not been connected to the PROFIBUS-DP network. 2. PROFIBUS-DP master has not configured AH10PFBS-5A slave or the configured node address of AH10PFBS-5A is inconsistent with that of the actually connected one.	The red light is ON.	The green light is ON.	The red light is ON.

### 9.2.11.AH10COPM-5A

Error code	Description	LED indicator status	
		CPU	Module
		BUS FAULT	ERROR
16#A0B0	AH10COPM-5A does not send a heartbeat message after a set period of time.	Blinking	The red light flashes twice.
16#A0B1	The length of a PDO that a slave station sends is not the same as the length of the PDO set in the node list.	Blinking	OFF
16#A0B2	The master station selected does not send a node guarding message after a set period of time.	Blinking	The red light flashes twice.
16#A0E0	AH10COPM-5A receives an emergency message from a slave station.	Blinking	OFF
16#A0E1	The length of a PDO that a slave station sends is not the same as the length of the PDO set in the node list.	Blinking	OFF
16#A0E2	AH10COPM-5A does not receive a PDO from a slave station.	Blinking	OFF
16#A0E3	An automatic SDO is not downloaded successfully.	Blinking	OFF
16#A0E4	A PDO parameter is not set successfully.	Blinking	OFF
16#A0E5	A key parameter is set incorrectly.	Blinking	OFF
16#A0E6	The actual network configuration is not the same as the network configuration set.	Blinking	OFF
16#A0E7	The control of the errors in a slave station is not sent after a set period of time.	Blinking	The red light flashes twice.
16#A0E8	The master station address is the same as a slave station address.	Blinking	OFF
16#A0F1	No slave station is added to the node list in CANopen builder.	Blinking	OFF
16#A0F3	An error occurs in AH10COPM-5A.	Blinking	OFF
16#A0F4	The bus used is off.	Blinking	The red light is ON.
16#A0F5	The node address of AH10COPM-5A is set incorrectly.	Blinking	OFF
16#A0F6	Internal error: An error occurs in the manufacturing process in the factory.	Blinking	OFF
16#A0F7	Internal error: GPIO error	Blinking	OFF
16#A0F8	Hardware error	Blinking	OFF
16#A0F9	Low voltage	Blinking	OFF
16#A0FA	An error occurs in the firmware of AH10COPM-5A.	Blinking	OFF

Error code	Description	LED indicator status	
		CPU	Module
		BUS FAULT	ERROR
16#A0FB	The transmission registers in AH10COPM-5A are full.	Blinking	OFF
16#A0FC	The reception registers in AH10COPM-5A are full.	Blinking	OFF

## 9.3 Troubleshooting for CPU

You can get the corrective actions from the tables below according to the error codes.

### 9.3.1. ERROR Indicator ON

Error Code	Description	Corrective action
16#000B	The program in the PLC is damaged.	Download the program again.
16#000D	The CPU parameters are damaged.	Reset the CPU parameter, and download it.
16#0010	The access to the memory in the CPU is denied.	Download the program or parameters again. If the problem still occurs, please contact the manufacturer.
16#0011	The PLC ID is incorrect. (SM9)	Please check the PLC ID.
16#0012	The PLC password is incorrect. (SM9)	Please check the PLC password.
16#0014	The procedure of restoring the system can not be executed. (SM9)	The contents of the system backup file are incorrect, or the file does not exist in the path specified. If the file exists and the procedure of restoring the system can not be executed, please back up the system again. If the error still occurs, please contact the manufacturer. (You can refer to <b>AH Motion Controller – Operation Manual</b> for more details about using memory cards)
16#0015	The module table is incorrect. (SM10)	The module table stored in the CPU module is incorrect. Compare the module table in HWCONFIG with the actual module configuration, and download the module table again.
16#0016	The module setting is incorrect. (SM10)	The module setting stored in the CPU module is incorrect. Check whether the version of the module inserted in the slot is the same as the version of the module in HWCONFIG. After the version of the module is updated, users can download the module setting again.
16#0017	The data register exceeds the device range. (SM10)	The data register stored in the CPU module exceeds the device range. Check whether the module parameter in HWCONFIG is correct, and download the module parameter again.
16#001B	Timed interrupt 0 is set incorrectly.	Set the CPU parameter in HWCONFIG again, and download the CPU parameter again.
16#001C	Timed interrupt 1 is set incorrectly.	Set the CPU parameter in HWCONFIG again, and download the CPU parameter again.

Error Code	Description	Corrective action
16#001D	Timed interrupt 2 is set incorrectly.	Set the CPU parameter in HWCONFIG again, and download the CPU parameter again.
16#001E	Timed interrupt 3 is set incorrectly.	Set the CPU parameter in HWCONFIG again, and download the CPU parameter again.
16#001F	The watchdog timer is set incorrectly.	Set the CPU parameter in HWCONFIG again, and download the CPU parameter again.
16#0020	The setting of the fixed scan time is incorrect.	Set the CPU parameter in HWCONFIG again, and download the CPU parameter again.
16#0021	The setting of the fixed scan time is incorrect.	Set the CPU parameter in HWCONFIG again, and download the CPU parameter again.
16#0022	The CPU parameter downloaded to the PLC is incorrect.	Download the CPU parameter again.
16#0023	CPU parameters setting error. The state of Y devices when the CPU is set from STOP to RUN is incorrect	Adjust the CPU parameters setting in HWCONFIG and download it to PLC again.
16#0025	CPU is lost or being reset. (in Module mode only)	Make sure the CPU is connected and rescan the downloaded HWCONFIG.
16#0026	The Communication Ratio box in the Communication Loading of Scan Time (%) section in the PLC Parameter Setting window is set incorrectly.	Reset the CPU or set the CPU to the default settings, and download the program and parameters again.
16#0027	The latching auxiliary relay range which is set is incorrect.	Reset the CPU or set the CPU to the default settings, and download the program and parameters again.
16#0028	The latching data register range which is set is incorrect.	Reset the CPU or set the CPU to the default settings, and download the program and parameters again.
16#0029	The latching timer range which is set is incorrect.	Reset the CPU or set the CPU to the default settings, and download the program and parameters again.
16#002A	The latching counter range which is set is incorrect.	Reset the CPU or set the CPU to the default settings, and download the program and parameters again.
16#002B	The latching 32-bit counter range which is set is incorrect.	Reset the CPU or set the CPU to the default settings, and download the program and parameters again.
16#0050	The memories in the latched special auxiliary relays are abnormal.	After users reset the CPU module or restore it to the factory setting, they can download the program and the parameter again.
16#0051	The latched special data registers are abnormal.	After users reset the CPU module or restore it to the factory setting, they can download the program and the parameter again.

Error Code	Description	Corrective action
16#0052	The memories in the latched auxiliary relays are abnormal.	After users reset the CPU module or restore it to the factory setting, they can download the program and the parameter again.
16#0053	The latched timers are abnormal.	After users reset the CPU module or restore it to the factory setting, they can download the program and the parameter again.
16#0054	The latched counters are abnormal.	After users reset the CPU module or restore it to the factory setting, they can download the program and the parameter again.
16#0055	The latched 32-bit counters are abnormal.	After users reset the CPU module or restore it to the factory setting, they can download the program and the parameter again.
16#0056	The memories in the latched timers are abnormal.	After users reset the CPU module or restore it to the factory setting, they can download the program and the parameter again.
16#0057	The memories in the latched counters are abnormal.	After users reset the CPU module or restore it to the factory setting, they can download the program and the parameter again.
16#0058	The memories in the latched 32-bit counters are abnormal.	After users reset the CPU module or restore it to the factory setting, they can download the program and the parameter again.
16#0059	The latched data registers are abnormal.	After users reset the CPU module or restore it to the factory setting, they can download the program and the parameter again.
16#005A	The latched working registers are abnormal.	After users reset the CPU module or restore it to the factory setting, they can download the program and the parameter again.

### 9.3.2. ERROR Indicator Blinking

Error Code	Description	Corrective action
16#000A	Scan timeout (SM8: The watchdog timer error)	<ol style="list-style-type: none"> <li>1. Check the setting of the watchdog timer in HWCONFIG.</li> <li>2. Check whether the program causes the long scan time</li> </ol>
16#000C	The program downloaded to the PLC is incorrect.	After users compile the program again, they can download the program again.
16#000E	The program or the parameter is being downloaded, and therefore the PLC can not run.	After the program or the parameter is downloaded to the PLC, users can try to run the PLC.

Error Code	Description	Corrective action
16#0018	The serial port is abnormal. (SM9)	Retry the connection. If the error still occurs, please contact the factory.
16#0019	The USB is abnormal. (SM9)	Retry the connection. If the error still occurs, please contact the factory.
16#001A	The contents of the system backup file (.dup file) are incorrect.	Create the system backup file again.
16#0033	The communication setting of COM1 is incorrect. (SM9)	<ol style="list-style-type: none"> <li>1. Check the program and the related special data registers.</li> <li>2. Set the communication port parameter for the CPU module in HWCONFIG again.</li> </ol>
16#0034	The setting of the station address of COM1 is incorrect. (SM9)	<ol style="list-style-type: none"> <li>1. Check the program and the related special data registers.</li> <li>2. Set the communication port parameter for the CPU module in HWCONFIG again.</li> </ol>
16#0035	The setting of the communication type of COM1 is incorrect. (SM9)	<ol style="list-style-type: none"> <li>1. Check the program and the related special data registers.</li> <li>2. Set the communication port parameter for the CPU module in HWCONFIG again.</li> </ol>
16#0038	The communication setting of COM2 is incorrect. (SM9)	<ol style="list-style-type: none"> <li>1. Check the program and the related special data registers.</li> <li>2. Set the communication port parameter for the CPU module in HWCONFIG again.</li> </ol>
16#0039	The setting of the station address of COM2 is incorrect. (SM9)	<ol style="list-style-type: none"> <li>1. Check the program and the related special data registers.</li> <li>2. Set the communication port parameter for the CPU module in HWCONFIG again.</li> </ol>
16#003A	The setting of the communication type of COM2 is incorrect. (SM9)	<ol style="list-style-type: none"> <li>1. Check the program and the related special data registers.</li> <li>2. Set the communication port parameter for the CPU module in HWCONFIG again.</li> </ol>
16#005D	The memory card cannot be deteted by the CPU module.	Make sure the memory card has been correctly inserted to the CPU module.
16#005E	The memory card is initialized incorrectly. (SM453)	Check whether the memory card is failing.
16#005F	The data is read from the inexistent file in the memory card, or the data is written into the inexistent file in the memory card. (SM453)	Make sure the file path is correct.
16#0060	The capacity of the memory card is not large enough. (SM453)	Check whether the memory capacity is large enough and the memory card functions normally

Error Code	Description	Corrective action
16#0061	The memory card is write protected. (SM453)	Check whether the memory capacity is large enough.
16#0062	An error occurs when the data is written into the memory card. (SM453)	Check whether the memory card is set to be read-only.
16#0063	The file in the memory card can not be read. (SM453)	Check whether the file path is correct and the memory card functions normally.
16#0064	The file in the memory card is a read-only file. (SM453)	Check whether the file path is correct and the file is damaged or not..
16#0065	An error occurs when the system is backed up.	Set the file not to be read-only.
16#0066	An error occurs when the system is backed up.	<ol style="list-style-type: none"> <li>1. Check whether the memory card is normal, and whether the capacity of the memory card is large enough.</li> <li>2. Retry the backup procedure. If the error still occurs, please contact the factory.</li> </ol>
16#0067	The size of the PLC parameters restored exceeds the size of the PLC parameters of the CPU module.	The error code is appeared to indicate alarm only.
16#2000	There is no END in the program in the PLC. (SM5)	<ol style="list-style-type: none"> <li>1. Compile the program again, and download the program again.</li> <li>2. Reinstall ISPSOft, compile the program again, and download the program again.</li> </ol>
16#2001	The program is incorrect. There is a syntax error.	Check the program, compile the program again, and download the program again.
16#2002	GOEND is used incorrectly. (SM5)	Check the program, compile the program again, and download the program again.
16#2003	The devices used in the program exceed the range. (SM0/SM5)	Check the program, compile the program again, and download the program again.
16#2004	The part of the program specified by the label used in CJ/JMP is incorrect, or the label is used repeatedly. (SM0/SM5)	Check the program, compile the program again, and download the program again.
16#2005	The N value used in MC is not the same as the corresponding N value used in MCR, or the number of N values used in MC is not the same as the number of N values used in MCR. (SM5)	Check the program, compile the program again, and download the program again.
16#2006	The N values used in MC do not start from 0, or the N values used in MC are not continuous. (SM5)	Check the program, compile the program again, and download the program again.

Error Code	Description	Corrective action
16#2007	The operands used in ZRST are not used properly. (SM5)	Check the program, compile the program again, and download the program again.
16#200A	Invalid instruction (SM5)	Check the program, compile the program again, and download the program again.
16#200B	The operand <b>n</b> or the other constant operands exceed the range. (SM0/SM5)	Check the program, compile the program again, and download the program again.
16#200C	The operands overlap. (SM0/SM5)	Check the program, compile the program again, and download the program again.
16#200D	An error occurs when the binary number is converted into the binary-coded decimal number. (SM0/SM5)	Check the program, compile the program again, and download the program again.
16#200E	The string does not end with 0x00. (SM0/SM5)	Check the program, compile the program again, and download the program again.
16#200F	The instruction does not support the modification by an index register. (SM5)	Check the program, compile the program again, and download the program again.
16#2010	<ol style="list-style-type: none"> <li>1. The instruction does not support the device.</li> <li>2. Encoding error</li> <li>3. The instruction is a 16-bit instruction, but the constant operand is a 32-bit code. (SM5)</li> </ol>	Check the program, compile the program again, and download the program again.
16#2011	The number of operands is incorrect. (SM5)	Check the program, compile the program again, and download the program again.
16#2012	Incorrect division operation (SM0/SM5).	Check the program, compile the program again, and download the program again.
16#2013	The value exceeds the range of values which can be represented by the floating-point numbers. (SM0/SM5)	Check the program, compile the program again, and download the program again.
16#2014	The task designated by TKON/TKOFF is incorrect, or exceeds the range. (SM5)	Check the program, compile the program again, and download the program again.
16#2015	There are more than 32 levels of nested program structures supported by CALL. (SM0)	Check the program, compile the program again, and download the program again.
16#2016	There are more than 32 levels of nested program structures supported by FOR/NEXT. (SM0/SM5)	Check the program, compile the program again, and download the program again.
16#2017	The number of times FOR is used is different from the number of times NEXT is used. (SM5)	Check the program, compile the program again, and download the program again.

Error Code	Description	Corrective action
16#2018	There is a label after FEND, but there is no SRET. Or there is SRET, but there is no label. (SM5)	<ol style="list-style-type: none"> <li>1. Compile the program again, and download the program again.</li> <li>2. Reinstall ISPSOft, compile the program again, and download the program again.</li> </ol>
16#2019	The interrupt task is not after FEND. (SM5)	<ol style="list-style-type: none"> <li>1. Compile the program again, and download the program again.</li> <li>2. Reinstall ISPSOft, compile the program again, and download the program again.</li> </ol>
16#201A	IRET/SRET is not after FEND. (SM5)	<ol style="list-style-type: none"> <li>1. Compile the program again, and download the program again.</li> <li>2. Reinstall ISPSOft, compile the program again, and download the program again.</li> </ol>
16#201B	There is an interrupt task, but there is no IRET. There is IRET, but there is not interrupt task. (SM5)	<ol style="list-style-type: none"> <li>1. Compile the program again, and download the program again.</li> <li>2. Reinstall ISPSOft, compile the program again, and download the program again.</li> </ol>
16#201C	End is not at the end of the program. (SM5)	<ol style="list-style-type: none"> <li>1. Compile the program again, and download the program again.</li> <li>2. Reinstall ISPSOft, compile the program again, and download the program again.</li> </ol>
16#201D	There is CALL, but there is no MAR. (SM5)	<ol style="list-style-type: none"> <li>1. Compile the program again, and download the program again.</li> <li>2. Reinstall ISPSOft, compile the program again, and download the program again.</li> </ol>
16#201E	The function code used in MODRW is incorrect. (SM102/SM103)	Check the usage of the instruction and the setting of the operands. Please refer to the explanation of the instruction MODRW in AH500 Programming Manual for more information.
16#201F	The length of the data set in MODRW is incorrect. (SM102/SM103)	Check the usage of the instruction and the setting of the operands. Please refer to the explanation of the instruction MODRW in AH500 Programming Manual for more information.
16#2020	The communication command received by using MODRW is incorrect. (SM102/SM103)	Check whether the slave supports the function code and the specified operation.
16#2021	The checksum of the command received by using MODRW is incorrect. (SM102/SM103)	<ol style="list-style-type: none"> <li>1. Check whether there is noise, and retry the sending of the command.</li> <li>2. Check whether the slave operates normally.</li> </ol>
16#2022	The format of the command used in MODRW does not conform to the ASCII format. (SM102/SM103)	Make sure that the format of the command conforms to the ASCII format.



Error Code	Description	Corrective action
16#2023	There is a communication timeout when MODRW is executed. (SM102/SM103)	Check whether the slave operates normally, and whether the connection is normal.
16#2024	The setting value of the communication timeout is invalid when RS is executed. (SM102/SM103)	1. Check the program and the related special data registers. 2. Set the communication port parameter for the CPU module in HWCONFIG again.
16#2025	There is a communication timeout when RS is executed. (SM102/SM103)	Check whether the slave operates normally, and whether the connection is normal.
16#2026	The interrupt number used in RS is incorrect.	Check whether the the interrupt service routine used in RS is downloaded.
16#2027	The execution of FWD is abnormal.	Please refer to AH500 Programming Manual, and check the instruction FWD.
16#2028	The execution of REV is abnormal.	Please refer to AH500 Programming Manual, and check the instruction REV.
16#2029	The execution of STOP is abnormal.	Please refer to AH500 Programming Manual, and check the instruction STOP.
16#202A	The execution of RSDT is abnormal.	Please refer to AH500 Programming Manual, and check the instruction RSDT.
16#202B	The execution of RSTEF is abnormal.	Please refer to AH500 Programming Manual, and check the instruction RSTEF.
16#202C   16#204B	I/O interrupt service routine 0 does not exist.   I/O interrupt service routine 31 does not exist.	Download I/O interrupt service routine 0 (I/O interrupt 0)   Download I/O interrupt service routine 31 (I/O interrupt 31)
16#2054   16#2127	External interrupt service routine 40 does not exist.   External interrupt service routine 251 does not exist.	Download external interrupt service routine 40 (external interrupt 40)   Download external interrupt service routine 251 (external interrupt 251)
16#2128	An action in a sequential function chart is incorrectly assigned qualifiers related to time.(SM0/SM1)	Check whether qualifiers related to time are duplicated when setting SFC action.
16#2129	The modifier R is assigned to an action in a sequential function chart incorrectly. (SM0/SM1)	Check whether there are conflict settings between properties when setting SFC action.
16#3040	Data in E-CAM exceeds the setting range or does not exist.	<b>Cause:</b> the E-CAM number has been input in the function block but it exceeds the setting range <b>Action:</b> modify the E-CAM number and set it within the setting range

Error Code	Description	Corrective action
16#3100	Input parameters exceed the available setting range.	Check whether the input parameters exceed the available setting range.
16#3102	An error occurs in a sub-function block inside the function block.	Re-execute the function block instruction.
16#3103	The distance between the detecting sensors used for identifying exceptional bags is a negative value.	Check whether the positions of the detecting sensors are correct.
16#3104	Phasing is executed again before the previous phasing is completed.	<b>Cause:</b> the instruction is executed again when <i>Done</i> is still False. <b>Action:</b> re-execute the instruction again.
16#3105	Superimposing is executed again before the previous superimposing is completed.	<b>Cause:</b> the instruction is executed again when <i>Done</i> is still False. <b>Action:</b> re-execute the instruction again.
16#3106	Chain position compensation is triggered before the previous compensation is completed.	<b>Cause:</b> the master axis moves too fast to allow the previous compensation to be finished. In this case, the compensation is triggered again. <b>Action:</b> adjust all packaging related parameters according to the application requirements.
16#3107	Film axis position compensation is triggered before the previous compensation is completed.	<b>Cause:</b> the master axis moves too fast to allow the previous compensation to be finished. In this case, the compensation is triggered again. <b>Action:</b> adjust all packaging related parameters according to the application requirements.
16#3108	Knife position compensation is triggered before the previous compensation is completed.	<b>Cause:</b> the master axis moves too fast to allow the previous compensation to be finished. In this case, the compensation is triggered again. <b>Action:</b> adjust all packaging related parameters according to the application requirements..
16#3400	The axis number exceeds the valid range.	<b>Cause:</b> The input number of axis is invalid. <b>Action:</b> Reset the axis number and re-execute the function block.
16#3401	SDO Data Type setting error (0~199)	<b>Cause:</b> The data type is not mapped to the corresponding object. <b>Action:</b> Check the definitions within the object dictionary of the slave.
16#3404	The channel number is greater than the total number of the channels.	<b>Cause:</b> The input number of the channel is not in the valid range. <b>Action:</b> Reset the channel number and re-execute the function block.

Error Code	Description	Corrective action
16#3405	A negative or 0 is given to <i>Velocity</i> .	<b>Cause:</b> the value given to <i>Velocity</i> is negative or 0. <b>Action:</b> set the velocity to a positive value and re-execute the instruction.
16#340A	Homing mode setting error.	<b>Cause:</b> homing mode is not set to a value between 1 and 35. <b>Action:</b> set homing mode to a value between 1 and 35 and re-execute the instruction.
16#340B	Target distance is 0.	<b>Cause:</b> target distance of this instruction is not set to 0. <b>Action:</b> set target distance to a positive value and re-execute the instruction.
16#340E	DFB_Compare Source setting error	<b>Cause:</b> the input value of Source in DFB_Compare exceeds the valid range (0~7). <b>Action:</b> reset the value of Source pin and re-execute the function block.
16#3410	User unit setting error; or the output pulse type setting error.	<b>Cause:</b> user unit setting of this instruction is not set to 0~2. <b>Action:</b> set the user unit to 0~2 and re-execute the instruction.
16#3411	Velocity factor overrides setting error.	<b>Cause:</b> velocity factor of this instruction is not set to 0~500. <b>Action:</b> set the velocity factor to 0~500 and re-execute the instruction.
16#3414	Pulse counting type setting error	<b>Cause:</b> the receiving data of pulse type is not set within the range 0~3. <b>Action:</b> reset the input pulse type and re-execute the function block.
16#3415	Comparison conditions setting error	<b>Cause:</b> the setting value is not in the range of 0~2. <b>Action:</b> reset the comparison conditions and re-execute the function block.
16#3419	Master axis position is negative value.	<b>Cause:</b> master axis position is set to a negative value or 0. <b>Action:</b> set the master axis position to a positive value and re-execute the instruction.
16#341B	Maximum speed setting error.	<b>Cause:</b> maximum speed is not set to 1~1,000,000. <b>Action:</b> set the maximum speed to 1~1,000,000 and re-execute the instruction.
16#3422	Wrong setting for the output device of DFB_Compare.	<b>Cause:</b> the input value of <b>OutputDevice</b> of DFB_Compare is out of the valid range (0~7). <b>Action:</b> reset the function block pin <b>OutputDevice</b> and re-execute the function block.

Error Code	Description	Corrective action
16#3429	Wrong Gcode number	<b>Cause:</b> There's an unsupported G code or wrong G code format in the file. <b>Action:</b> Check the G code file and modify unsupported G codes and wrong formats, then download the file again.
16#342A	Gcode source error	<b>Cause:</b> The G code file specified with GcodeID does not exist in the AH Motion CPU or the SD card. <b>Action:</b> Modify GcodeID of the function block and reactivate the function block after the file is checked to be in the AH Motion CPU or the SD card.
16#342B	GcodeID setting exceeds valid range.	<b>Cause:</b> the input value for GcodeID is not in the range of 1 ~ 136. <b>Action:</b> modify GcodeID to be within 1 to 136 and re-execute the function block.
16#342C	Gcode is running.	<b>Cause:</b> the corresponding axis group is running DFB_GroupGcodeRun. <b>Action:</b> After finish running DFB_GroupGcodeRun, the function block would be able to be executed.
16#342D	Gcode grammar is being checked.	<b>Cause:</b> the corresponding is running DFB_GroupGcodeSyntax. <b>Action:</b> After finish running DFB_GroupGcodeRun, the function block would be able to be executed.
16#342E	Gcode Filter setting is not in the valid range.	<b>Cause:</b> the setting value of DFB_GroupRun Filter run by the corresponding axis group is a negative value or greater than 1000. <b>Action:</b> reset the value of Filter so as to activate the function block.
16#3430	Duplicate GroupNum	<b>Cause:</b> Duplicate axis group number <b>Action:</b> Troubleshoot the problem with DFB_GroupReset.
16#3431	Duplicate axis number in the group	<b>Cause:</b> There're duplicate values (AxisNumorder1~ AxisNumorder6) in DFB_GroupEnable. <b>Action:</b> Reset values of AxisNumorder1 to AxisNumorder6 and activate the function block again.
16#3432	GroupNum does not exist	<b>Cause:</b> Group specified by GroupNum is not valid. <b>Action:</b> Reset GroupNum to a valid Group.

Error Code	Description	Corrective action
16#3433	The number of axes in the group is inadequate.	<b>Cause:</b> The number of axes in Group specified by GroupNum is inadequate. <b>Action:</b> Reset <b>GroupNum</b> of the function block and make sure the axes number in the specified group meets the quantity demands. For example, there should be at least 2 axes for linear interpolation in Group while the minimum requirement of axes number for circular interpolation is 3.
16#3434	Execute DFB_GroupDisable while the axis group is running.	<b>Cause:</b> The active axes group is compulsorily disabled. <b>Action:</b> Execute <b>DFB_GroupReset</b> to clear the wrong Group state.
16#3435	The axis has been specified in other axes group.	<b>Cause:</b> Some axes specified by AxisNumorder1~AxisNumorder6 have been used in other axes groups when <b>DFB_GroupEnable</b> is executed. <b>Action:</b> Reset <b>AxisNumorder1~AxisNumorder6</b> so as not to share the same axes in different groups.
16#3436	The specified axis number starts from 0 in GroupNum.	<b>Cause:</b> The input value of <b>AxisNumorder1</b> is a negative value or 0 in DFB_GroupEnable. <b>Action:</b> Modify the value of <b>AxisNumorder1</b> to be greater than 0 and re-execute <b>DFB_GroupEnable</b> .
16#3437	GroupNum setting exceeds the valid range.	<b>Cause:</b> The input value of GroupNum is not within 1 ~ 32. <b>Action:</b> Reset the value of GroupNum and re-execute the function block.
16#3438	GroupNum is in ErrorStop state.	<b>Cause:</b> An error occurs to Group when the function block is executed. <b>Action:</b> Execute <b>DFB_GroupReset</b> to clear the error.
16#343A	Execute ImmediateStop to Group.	<b>Cause:</b> An emergency stop is performed to the axes group. <b>Action:</b> Execute <b>DFB_GroupReset</b> to clear the error.
16#343B	Error occurred in the other axis of the group	<b>Cause:</b> Error occurred in the other axis of the group. <b>Action:</b> Use DFB_GroupReset to clear the error code.
16#343C	Conditions from GroupEllipse could not be fulfilled.	<b>Cause:</b> The conditions cannot be fulfilled. <b>Action:</b> Check whether the conditions are consistent with physics laws.
16#343D	The state of axis in Group is incorrect.	<b>Cause:</b> The axes group is switched to a wrong state. <b>Action:</b> Check if there's any unreasonable change in axes group state.
16#343E	Use DFB_GroupReset to troubleshoot errors when the axis is in CoordinatedHalt state.	<b>Cause:</b> The axis is in CoordinatedHalt state. <b>Action:</b> Execute <b>DFB_GroupReset</b> to clear the error.

Error Code	Description	Corrective action
16#3461	The required communication parameters for PDO settings are not specified	<b>Cause:</b> the required communication parameters for PDO settings are not specified when the function block is in execution. <b>Action:</b> re-execute ECAT Builder and specify the required parameters for the function block.
16#3500	The axis is not in the ready state.	<b>Cause:</b> the selected channel has been used. <b>Action:</b> stop the current operation of FB.
16#3501	The selected channel has been used in FB.	<b>Cause:</b> the axis is busy. <b>Action:</b> stop the current operation or wait till the operation stops.
16#3502	The position is not allowed for setup.	<b>Cause:</b> the target position of the function block exceeds the software limit or an axis of rotation or the position is an illegal one. <b>Action:</b> set up a new target position
16#3505	An error occurs when writing cam data.	<b>Cause:</b> there's no coherence between the writing and reading cam data. <b>Action:</b> re-execute the function block for writing cam data.
16#3506	The axis is in "Coordinated"	<b>Cause:</b> the axis is in "Coordinated" when MC_stop is executed. <b>Action:</b> confirm that <i>Execute</i> =False and <i>Done</i> =True in MC_Stop. Use DFB_GroupReset to reset the axis to "Standby" and use DFB_GroupDisable to disable the group motion.
16#3507	The axis is in "ErrorStop"	<b>Cause:</b> The axis is in "ErrorStop" when the instruction is executed. <b>Action:</b> use MC_Reset to reset the axis error status.
16#3508	The axis is not in "Standstill"	<b>Cause:</b> the axis is not in "Standstill" when the instruction is executed. <b>Action:</b> execute MC_Reset and confirm is the axis is in "Standstill"
16#3509	The axis is in the "Stopping" state	<b>Cause:</b> the axis is in the "Stopping" state. <b>Action:</b> close the MC_Stop function block and have the state go back to StandStill
16#350B	The acceleration time for the axis is too short.	<b>Cause:</b> the acceleration time for the axis is set too short. <b>Action:</b> adjust the acceleration or increase the time to accelerate for the axis.
16#350C	The deceleration time for the axis is too short.	<b>Cause:</b> the deceleration time for the axis is set too short. <b>Action:</b> adjust the deceleration or increase the time to decelerate for the axis.
16#350D	The E-CAM data exceeds the to-read range	<b>Cause:</b> the to-read data length exceeds the setting range <b>Action:</b> adjust the to-read data length (1~256)
16#350E	The E-CAM data exceeds the to-be written range.	<b>Cause:</b> the to-read data length exceeds the setting range <b>Action:</b> adjust the to-read data length (1~256)

Error Code	Description	Corrective action
16#350F	The axis is in the "Synchronized" state.	<b>Cause:</b> the axis is in the "Synchronized" state when the MC_SetOverride is started. <b>Action:</b> do not have the axis in the "Synchronized" state.
16#3510	Cam curve linear speed setting error	<b>Cause:</b> choose linear as the curve type in <b>DFB_CamKeyPointWrite</b> , but the speed of two end points is different. <b>Action:</b> set the same speed to the both end points of the straight line.
16#3511	Cam curve linear acceleration setting error	<b>Cause:</b> acceleration at both ends is not 0 while the curve type in <b>DFB_CamKeyPointWrite</b> is set to linear. <b>Action:</b> Acceleration at both ends should be set to 0.
16#3512	Cam data does not exist.	<b>Cause:</b> the desired cam data does not exist. <b>Action:</b> check if the desired cam point is wrong. If not, please download the CAM Table again.
16#3513	The position of master axis is set to be less than the previous point	<b>Cause:</b> The position of master axis is set to be less than or equal to the previous point on the CAM table. <b>Action:</b> Make sure the cam points that you write in is correct.
16#3514	Cam percentage exceeds the setting range (0~100).	<b>Cause:</b> Cam percentage is not set between 0 to 100 in <b>DFB_CamSwitch</b> . <b>Action:</b> reset the percentage to be within the range of 0~100.
16#3515	The material length of CamCurve_TMRC exceeds the valid range.	<b>Cause:</b> input parameters cannot conform to the physical limitations. <b>Action:</b> input appropriate values and execute the function block again.
16#3516	The circumference of CamCurve_TMRC rotary cutting exceeds the valid range.	<b>Cause:</b> input parameters cannot conform to the physical limitations. <b>Action:</b> input appropriate values and execute the function block again.
16#3517	The number of CamCurve_TMRC rotary cutter exceeds the valid range.	<b>Cause:</b> input parameters cannot conform to the physical limitations. <b>Action:</b> input appropriate values and execute the function block again.
16#3518	The beginning angle of CamCurve_TMRC sync. zone exceeds the valid range.	<b>Cause:</b> input parameters cannot conform to the physical limitations. <b>Action:</b> input appropriate values and execute the function block again.
16#3519	The ending angle of CamCurve_TMRC sync. zone exceeds the valid range.	<b>Cause:</b> input parameters cannot conform to the physical limitations. <b>Action:</b> input appropriate values and execute the function block again.
16#351A	The beginning angle of CamCurve_TMRC sync. zone is greater than the ending angle.	<b>Cause:</b> input parameters cannot conform to the physical limitations. <b>Action:</b> input appropriate values and execute the function block again.

Error Code	Description	Corrective action
16#351B	The sync. zone of CamCurve_TMRCrotary is too large.	<b>Cause:</b> input parameters cannot conform to the physical limitations. <b>Action:</b> input appropriate values and execute the function block again.
16#3522	Flash data is damaged.	<b>Cause:</b> Flash data is damaged. <b>Action:</b> Rebuild the flash data.
16#3526	Error occurs in the previous movement of the axis	<b>Cause:</b> error occurs in the axis <b>Action:</b> clear error
16#3530	The material length of CamCurve_FRC is 0 or a negative value.	<b>Cause:</b> input parameters cannot conform to the physical limitations. <b>Action:</b> input appropriate values and execute the function block again.
16#3531	The material length in CamCurve_FRC acceleration zone is a negative value.	<b>Cause:</b> input parameters cannot conform to the physical limitations. <b>Action:</b> input appropriate values and execute the function block again.
16#3533	The material length in CamCurve_FRC synchronization zone is 0 or a negative value.	<b>Cause:</b> input parameters cannot conform to the physical limitations. <b>Action:</b> input appropriate values and execute the function block again.
16#3534	The material length in CamCurve_FRC deceleration zone is a negative value.	<b>Cause:</b> input parameters cannot conform to the physical limitations. <b>Action:</b> input appropriate values and execute the function block again.
16#3536	The material length in CamCurve_FRC jerk zone is a negative value.	<b>Cause:</b> input parameters cannot conform to the physical limitations. <b>Action:</b> input appropriate values and execute the function block again.
16#3537	Excessive displacement of material in CamCurve_FRC synchronization zone.	<b>Cause:</b> input parameters cannot conform to the physical limitations. <b>Action:</b> input appropriate values and execute the function block again.
16#3538	Displacement of material in CamCurve_FRC synchronization zone is inadequate.	<b>Cause:</b> input parameters cannot conform to the physical limitations. <b>Action:</b> input appropriate values and execute the function block again.
16#3539	Material lengths in CamCurve_FRC acceleration and synchronization zone are greater than the total length of the material.	<b>Cause:</b> input parameters cannot conform to the physical limitations. <b>Action:</b> input appropriate values and execute the function block again.
16#353A	The circumference of CamCurve_FRC cutting is 0 or a negative value.	<b>Cause:</b> input parameters cannot conform to the physical limitations. <b>Action:</b> input appropriate values and execute the function block again.



Error Code	Description	Corrective action
16#353B	The cutting length in CamCurve_FRC synchronization zone is a negative value.	<b>Cause:</b> input parameters cannot conform to the physical limitations. <b>Action:</b> input appropriate values and execute the function block again.
16#353C	Excessive cutting length in CamCurve_FRC synchronization zone.	<b>Cause:</b> input parameters cannot conform to the physical limitations. <b>Action:</b> input appropriate values and execute the function block again.
16#353D	The number of CamCurve_FRC cutter exceeds the valid range.	<b>Cause:</b> input parameters cannot conform to the physical limitations. <b>Action:</b> input appropriate values and execute the function block again.
16#3540	The material length of CamCurve_FRC_WASAW_sType is a negative value.	<b>Cause:</b> input parameters cannot conform to the physical limitations. <b>Action:</b> input appropriate values and execute the function block again.
16#3541	The cutting length in CamCurve_FRC_WASAW_sType acceleration zone is 0 or a negative value.	<b>Cause:</b> input parameters cannot conform to the physical limitations. <b>Action:</b> input appropriate values and execute the function block again.
16#3542	The material length of CamCurve_FRC_WASAW_sType is shorter than the length in synchronization zone.	<b>Cause:</b> input parameters cannot conform to the physical limitations. <b>Action:</b> input appropriate values and execute the function block again.
16#3543	The material length in CamCurve_FRC_WASAW_sType synchronization zone is 0 or a negative value.	<b>Cause:</b> input parameters cannot conform to the physical limitations. <b>Action:</b> input appropriate values and execute the function block again.
16#3544	The cutting length in CamCurve_FRC_WASAW_sType deceleration zone is 0 or a negative value.	<b>Cause:</b> input parameters cannot conform to the physical limitations. <b>Action:</b> input appropriate values and execute the function block again.
16#3546	The cutting length in CamCurve_FRC_WASAW_sType jerk zone is a negative value.	<b>Cause:</b> input parameters cannot conform to the physical limitations. <b>Action:</b> input appropriate values and execute the function block again.
16#3547	The material length in the forepart of CamCurve_FRC_WASAW_sType unsynchronized section is a negative value.	<b>Cause:</b> input parameters cannot conform to the physical limitations. <b>Action:</b> input appropriate values and execute the function block again.
16#3548	The material length in the final part of CamCurve_FRC_WASAW_sType unsynchronized section is a negative value.	<b>Cause:</b> input parameters cannot conform to the physical limitations. <b>Action:</b> input appropriate values and execute the function block again.

Error Code	Description	Corrective action
16#3549	Material lengths in CamCurve_FRC_WASAW_sType acceleration, deceleration and synchronization zone are longer than the total length of the material.	<b>Cause:</b> input parameters cannot conform to the physical limitations. <b>Action:</b> input appropriate values and execute the function block again.
16#354A	Cutting lengths in CamCurve_FRC_WASAW_sType acceleration, and synchronization zone are longer than the total circumference of the cutter.	<b>Cause:</b> input parameters cannot conform to the physical limitations. <b>Action:</b> input appropriate values and execute the function block again.
16#354B	The circumference of CamCurve_FRC_WASAW_sType cutting is 0 or a negative value.	<b>Cause:</b> input parameters cannot conform to the physical limitations. <b>Action:</b> input appropriate values and execute the function block again.
16#354C	The cutting length in CamCurve_FRC_WASAW_sType synchronization zone is a negative value.	<b>Cause:</b> input parameters cannot conform to the physical limitations. <b>Action:</b> input appropriate values and execute the function block again.
16#354D	The linear cutting velocity of CamCurve_FRC_WASAW_sType in unsynchronized section is a negative value.	<b>Cause:</b> input parameters cannot conform to the physical limitations. <b>Action:</b> input appropriate values and execute the function block again.
16#354E	The number of CamCurve_FRC_WASAW_sType cutter exceeds the valid range.	<b>Cause:</b> input parameters cannot conform to the physical limitations. <b>Action:</b> input appropriate values and execute the function block again.
16#3550	The material length of CamCurve_FRC_SAWAS_sType is a negative value.	<b>Cause:</b> input parameters cannot conform to the physical limitations. <b>Action:</b> input appropriate values and execute the function block again.
16#3551	The cutting length in CamCurve_FRC_SAWAS_sType acceleration zone is 0 or a negative value.	<b>Cause:</b> input parameters cannot conform to the physical limitations. <b>Action:</b> input appropriate values and execute the function block again.
16#3552	The material length of CamCurve_FRC_SAWAS_sType is shorter than the length in synchronization zone.	<b>Cause:</b> input parameters cannot conform to the physical limitations. <b>Action:</b> input appropriate values and execute the function block again.
16#3553	The material length in CamCurve_FRC_SAWAS_sType synchronization zone is 0 or a negative value.	<b>Cause:</b> input parameters cannot conform to the physical limitations. <b>Action:</b> input appropriate values and execute the function block again.
16#3554	The cutting length in CamCurve_FRC_SAWAS_sType deceleration zone is 0 or a negative value.	<b>Cause:</b> input parameters cannot conform to the physical limitations. <b>Action:</b> input appropriate values and execute the function block again.

Error Code	Description	Corrective action
16#3556	The cutting length in CamCurve_FRC_SAWAS_sType jerk zone is a negative value.	<b>Cause:</b> input parameters cannot conform to the physical limitations. <b>Action:</b> input appropriate values and execute the function block again.
16#3557	The material length in the forepart of CamCurve_FRC_SAWAS_sType synchronization zone is a negative value.	<b>Cause:</b> input parameters cannot conform to the physical limitations. <b>Action:</b> input appropriate values and execute the function block again.
16#3558	The material length in the final part of CamCurve_FRC_SAWAS_sType synchronization zone is a negative value.	<b>Cause:</b> input parameters cannot conform to the physical limitations. <b>Action:</b> input appropriate values and execute the function block again.
16#3559	Material lengths in CamCurve_FRC_SAWAS_sType acceleration, deceleration and synchronization zone are longer than the total length of the material.	<b>Cause:</b> input parameters cannot conform to the physical limitations. <b>Action:</b> input appropriate values and execute the function block again.
16#355A	Cutting lengths in CamCurve_FRC_SAWAS_sType acceleration, and synchronization zone are longer than the total circumference of the cutter.	<b>Cause:</b> input parameters cannot conform to the physical limitations. <b>Action:</b> input appropriate values and execute the function block again.
16#355B	The cutter circumference of CamCurve_FRC_SAWAS_sType is 0 or a negative value.	<b>Cause:</b> input parameters cannot conform to the physical limitations. <b>Action:</b> input appropriate values and execute the function block again.
16#355C	The cutting length in CamCurve_FRC_SAWAS_sType synchronization zone is a negative value.	<b>Cause:</b> input parameters cannot conform to the physical limitations. <b>Action:</b> input appropriate values and execute the function block again.
16#355D	The linear cutting velocity of CamCurve_FRC_SAWAS_sType in unsynchronized section is a negative value.	<b>Cause:</b> input parameters cannot conform to the physical limitations. <b>Action:</b> input appropriate values and execute the function block again.
16#355E	The number of CamCurve_FRC_SAWAS_sType cutter exceeds the valid range.	<b>Cause:</b> input parameters cannot conform to the physical limitations. <b>Action:</b> input appropriate values and execute the function block again.
16#3600	The state of axis is incorrect.	<b>Cause:</b> the axis is not in the ready state to execute the instruction. <b>Action:</b> this error will cause the axis state to be in ErrorStop; users need to execute MC_Reset to have the axis state back to StandStill. Check the state description and see if there are any contradictions.

Error Code	Description	Corrective action
16#3601	The limit of the number of buffering instructions is reached	<b>Cause:</b> the number of buffering instructions (with buffer mode enabled) reached 20. <b>Action:</b> 1. The error status will lead the axis to "ErrorStop". In this case, execute MC_Reset to set the axis back to "Standstill". 2. Make sure the total number of buffering instructions is less than 20 before executing current instruction.
16#3602	A multiple instructions which are not allowed to be executed at the same time are executed.	<b>Cause:</b> the instruction is executed when another instruction is in execution at the same time. (Both do not support simultaneously execution) <b>Action:</b> use MC_Reset to clear the axis error, and set the axis state to "StandStill."
16#3603	Buffermode parameter setting error	<b>Cause:</b> the set value in <i>Buffermode</i> is not valid. <b>Action:</b> use MC_Reset to clear the axis error, and specify the input parameters again.
16#3604	Errors occur on the motion direction of the function block	<b>Cause:</b> the moving direction of the axis is not correct. <b>Action:</b> use MC_Reset to clear the axis error, and specify the input parameters again.
16#3605	P1 exceeds the available range	<b>Cause:</b> the target position is not specified with an available value. <b>Action:</b> use MC_Reset to clear the axis error, and specify the input parameters again.
16#3606	P2 exceeds the available range	<b>Cause:</b> the target position is not specified with an available value. <b>Action:</b> use MC_Reset to clear the axis error, and specify the input parameters again.
16#3607	V1 exceeds the available range	<b>Cause:</b> the target velocity is not specified with an available value. <b>Action:</b> use MC_Reset to clear the axis error, and specify the input parameters again.
16#3608	V2 exceeds the available range	<b>Cause:</b> the target velocity is not specified with an available value. <b>Action:</b> use MC_Reset to clear the axis error, and specify the input parameters again.
16#3612	It has reached the positive limit.	<b>Cause:</b> positive limit is reached. <b>Action:</b> use MC_Reset to clear the axis error, and move the position potively or negatively to the proprer position.
16#3613	It has reached the negative limit.	<b>Cause:</b> negative limit is reached. <b>Action:</b> use MC_Reset to clear the axis error, and move the position potively or negatively to the proprer position.

Error Code	Description	Corrective action
16#3614	The servo limit is exceeded.	<b>Cause:</b> the servo drive limit is reached. <b>Action:</b> use MC_Reset to clear the axis error, and move the position positively or negatively to the proper position.
16#3617	The acceleration exceeds the setting range.	<b>Cause:</b> when executing, the acceleration exceeds the maximum acceleration value, or buffering exceeds the maximum acceleration value. <b>Action:</b> set up the function block or the acceleration value
16#3618	The deceleration exceeds the setting range.	<b>Cause:</b> : when executing, the acceleration exceeds the maximum deceleration value, or buffering exceeds the maximum deceleration value. <b>Action:</b> set up the function block or the deceleration value
16#3619	The station does not exist.	<b>Cause:</b> The address does not exist. <b>Action:</b> check the address and restart the function block.
16#3620	The schedule buffer section of SDO is full.	<b>Cause:</b> The schedule buffer section of SDO is full. <b>Action:</b> wait till the schedule buffer section of SDO is less full to restart the function block.
16#3622	SDO OD data type is not matched.	<b>Cause:</b> SDO OD data type is not matched. <b>Action:</b> check the OD data type is correct and restart the function block.
16#3623	SDO is overtime.	<b>Cause:</b> SDO is overtime. <b>Action:</b> check the connection and restart the function block.
16#3624	SDO data written error.	<b>Cause:</b> error occurs in the slave <b>Action:</b> clear the error and restart the function block
16#3625	SDO data reading error.	<b>Cause:</b> error occurs in the slave <b>Action:</b> clear the error and restart the function block
16#3626	The number of SDO retry exceeds the setting range.	<b>Cause:</b> the number of SDO retry exceeds the setting range <b>Action:</b> check the address and restart the function block
16#3627	Displacement of the function block is greater than 2147483647.	<b>Cause:</b> Displacement of the function block is greater than 2147483647. <b>Action:</b> reset the target position of the function block or the number of pulses per circle rotating for a motor as well as the proportion of moving distance.
16#3630	AxisPara setting error.	<b>Cause:</b> axis parameter setting is wrong <b>Action:</b> adjust AxisPara input value and restart the function block
16#3631	AxisPara.GearRatioNume / GearRatioDeno unable to set servos.	<b>Cause:</b> the written gear ratio of SDO is wrong <b>Action:</b> check the reading and writing of SDO to ensure execution.

Error Code	Description	Corrective action
16#3632	Axis parameter cannot be modified.	<b>Cause:</b> members of AxisPara cannot be modified <b>Action:</b> adjust the input values of AxisPara members and restart the function blocks
16#3633	Axis parameter setting error.	<b>Cause:</b> the AxisPara setting is wrong. <b>Action:</b> adjust AxisPara input values and restart the function blocks
16#3634	AxisPara.SWPosLimit and AxisPara.SWNegLimit setting range error (both parameters are 0, the ranges are 0; the range does not include the current instruction position)	<b>Cause:</b> the setting range of AxisPara.SWPosLimit and AxisPara.SWNegLimit is wrong (both parameters are 0, the ranges are 0; the range does not include the current instruction position.) <b>Action:</b> adjust AxisPara.SWPosLimit and AxisPara.SWNegLimit input values, then restart the function bloc.
16#3635	AxisPara.RotaryMaxPos and AxisPara.RotaryMinPos setting range error (both parameters are 0, the ranges are 0)	<b>Cause:</b> the setting range of AxisPara.RotaryMaxPos and AxisPara.RotaryMinPos is wrong (both parameters are 0, the ranges are 0) <b>Action:</b> adjust AxisPara.RotaryMaxPos and AxisPara.RotaryMinPos input values, then restart the function block.
16#3636	GearRatio cannot be modified when the axis is not in Disabled state.	<b>Cause:</b> AxisPara.AxisType cannot be modified. <b>Action:</b> modify the input values of AxisPara.GearRatioNum and AxisPara.GearRatioDen or disable the axis, then re-execute the function block.
16#3637	The max. value of rotary axis position exceeds the valid range.	<b>Cause:</b> The max. value of rotary axis position for pulse unit is set to be greater than 2147483647. <b>Action:</b> Reset the max. value of rotary axis position or adjust the percentage setting under user-defined unit.
16#3638	The min. value of rotary axis position exceeds the valid range.	<b>Cause:</b> The min. value of rotary axis position for pulse unit is set to be smaller than -2147483648 <b>Action:</b> Reset the min. value of rotary axis position or adjust the percentage setting under user-defined unit.
16#3639	Max. position value of rotary axes <= Min. position value of rotary axes	<b>Cause:</b> The max. position value of rotary axes is set to be smaller or equal to the min. position value. <b>Action:</b> Reset the max. value of rotary axis position or the min. value of rotary axis position.
16#3640	After the axis positioning is performed, the actual position of the servo axis could not reach the assigned position within the error margins.	<b>Cause:</b> Axis parameters and following error are not configured properly according to the machine conditions. <b>Action:</b> Use MC_Reset to clear errors by modifying axis parameters and following error according to the machine conditions.
16#3700	Wrong state transition : Changing the state of a single axis from DiscreteMotion to Homing is not allowed.	<b>Cause:</b> After the function block is executed, the current axis cannot perform the corresponding function. <b>Action:</b> 1. When this error occurs, the axis state would be in ErrorStop. And MC_Reset needs to be executed so as to make the axis back to StandStill state. 2. Based on the status description, check whether there's any inconsistent status change in the program.

Error Code	Description	Corrective action
16#3701	Wrong state transition : Changing the state of a single axis from DiscreteMotion to CoordinatedHalt is not allowed.	<p><b>Cause:</b> After the function block is executed, the current axis cannot perform the corresponding function.</p> <p><b>Action:</b></p> <ol style="list-style-type: none"> <li>1. When this error occurs, the axis state would be in ErrorStop. And MC_Reset needs to be executed so as to make the axis back to StandStill state.</li> <li>2. Based on the status description, check whether there's any inconsistent status change in the program.</li> </ol>
16#3702	Wrong state transition : Changing the state of a single axis from DiscreteMotion to Coordinated is not allowed.	<p><b>Cause:</b> After the function block is executed, the current axis cannot perform the corresponding function.</p> <p><b>Action:</b></p> <ol style="list-style-type: none"> <li>1. When this error occurs, the axis state would be in ErrorStop. And MC_Reset needs to be executed so as to make the axis back to StandStill state.</li> <li>2. Based on the status description, check whether there's any inconsistent status change in the program.</li> </ol>
16#3703	Wrong state transition : Changing the state of a single axis from DiscreteMotion to CoordinatedStop is not allowed.	<p><b>Cause:</b> After the function block is executed, the current axis cannot perform the corresponding function.</p> <p><b>Action:</b></p> <ol style="list-style-type: none"> <li>1. When this error occurs, the axis state would be in ErrorStop. And MC_Reset needs to be executed so as to make the axis back to StandStill state.</li> <li>2. Based on the status description, check whether there's any inconsistent status change in the program.</li> </ol>
16#3704	Wrong state transition : Changing the state of a single axis from SynchronizedMotion to Homing is not allowed.	<p><b>Cause:</b> After the function block is executed, the current axis cannot perform the corresponding function.</p> <p><b>Action:</b></p> <ol style="list-style-type: none"> <li>1. When this error occurs, the axis state would be in ErrorStop. And MC_Reset needs to be executed so as to make the axis back to StandStill state.</li> <li>2. Based on the status description, check whether there's any inconsistent status change in the program.</li> </ol>
16#3705	Wrong state transition : Changing the state of a single axis from SynchronizedMotion to Standstill is not allowed.	<p><b>Cause:</b> After the function block is executed, the current axis cannot perform the corresponding function.</p> <p><b>Action:</b></p> <ol style="list-style-type: none"> <li>1. When this error occurs, the axis state would be in ErrorStop. And MC_Reset needs to be executed so as to make the axis back to StandStill state.</li> <li>2. Based on the status description, check whether there's any inconsistent status change in the program.</li> </ol>
16#3706	Wrong state transition : Changing the state of a single axis from SynchronizedMotion to CoordinatedHalt is not allowed.	<p><b>Cause:</b> After the function block is executed, the current axis cannot perform the corresponding function.</p> <p><b>Action:</b></p> <ol style="list-style-type: none"> <li>1. When this error occurs, the axis state would be in ErrorStop. And MC_Reset needs to be executed so as to make the axis back to StandStill state.</li> <li>2. Based on the status description, check whether there's any inconsistent status change in the program.</li> </ol>

Error Code	Description	Corrective action
16#3707	Wrong state transition : Changing the state of a single axis from SynchronizedMotion to Coordinated is not allowed.	<p><b>Cause:</b> After the function block is executed, the current axis cannot perform the corresponding function.</p> <p><b>Action:</b></p> <ol style="list-style-type: none"> <li>1. When this error occurs, the axis state would be in ErrorStop. And MC_Reset needs to be executed so as to make the axis back to StandStill state.</li> <li>2. Based on the status description, check whether there's any inconsistent status change in the program.</li> </ol>
16#3708	Wrong state transition : Changing the state of a single axis from SynchronizedMotion to CoordinatedStop is not allowed.	<p><b>Cause:</b> After the function block is executed, the current axis cannot perform the corresponding function.</p> <p><b>Action:</b></p> <ol style="list-style-type: none"> <li>1. When this error occurs, the axis state would be in ErrorStop. And MC_Reset needs to be executed so as to make the axis back to StandStill state.</li> <li>2. Based on the status description, check whether there's any inconsistent status change in the program.</li> </ol>
16#3709	Wrong state transition : Changing the state of a single axis from ContinuousMotion to Standstill is not allowed.	<p><b>Cause:</b> After the function block is executed, the current axis cannot perform the corresponding function.</p> <p><b>Action:</b></p> <ol style="list-style-type: none"> <li>1. When this error occurs, the axis state would be in ErrorStop. And MC_Reset needs to be executed so as to make the axis back to StandStill state.</li> <li>2. Based on the status description, check whether there's any inconsistent status change in the program.</li> </ol>
16#370A	Wrong state transition : Changing the state of a single axis from ContinuousMotion to CoordinatedHalt is not allowed.	<p><b>Cause:</b> After the function block is executed, the current axis cannot perform the corresponding function.</p> <p><b>Action:</b></p> <ol style="list-style-type: none"> <li>1. When this error occurs, the axis state would be in ErrorStop. And MC_Reset needs to be executed so as to make the axis back to StandStill state.</li> <li>2. Based on the status description, check whether there's any inconsistent status change in the program.</li> </ol>
16#370B	Wrong state transition : Changing the state of a single axis from ContinuousMotion to Coordinated is not allowed.	<p><b>Cause:</b> After the function block is executed, the current axis cannot perform the corresponding function.</p> <p><b>Action:</b></p> <ol style="list-style-type: none"> <li>1. When this error occurs, the axis state would be in ErrorStop. And MC_Reset needs to be executed so as to make the axis back to StandStill state.</li> <li>2. Based on the status description, check whether there's any inconsistent status change in the program.</li> </ol>
16#370C	Wrong state transition : Changing the state of a single axis from ContinuousMotion to CoordinatedStop is not allowed.	<p><b>Cause:</b> After the function block is executed, the current axis cannot perform the corresponding function.</p> <p><b>Action:</b></p> <ol style="list-style-type: none"> <li>1. When this error occurs, the axis state would be in ErrorStop. And MC_Reset needs to be executed so as to make the axis back to StandStill state.</li> <li>2. Based on the status description, check whether there's any inconsistent status change in the program.</li> </ol>



Error Code	Description	Corrective action
16#370D	Wrong state transition : Changing the state of a single axis from Stopping to DiscreteMotion is not allowed.	<p><b>Cause:</b> After the function block is executed, the current axis cannot perform the corresponding function.</p> <p><b>Action:</b></p> <ol style="list-style-type: none"> <li>1. When this error occurs, the axis state would be in ErrorStop. And MC_Reset needs to be executed so as to make the axis back to StandStill state.</li> <li>2. Based on the status description, check whether there's any inconsistent status change in the program.</li> </ol>
16#370E	Wrong state transition : Changing the state of a single axis from Stopping to SynchronizedMotion is not allowed.	<p><b>Cause:</b> After the function block is executed, the current axis cannot perform the corresponding function.</p> <p><b>Action:</b></p> <ol style="list-style-type: none"> <li>1. When this error occurs, the axis state would be in ErrorStop. And MC_Reset needs to be executed so as to make the axis back to StandStill state.</li> <li>2. Based on the status description, check whether there's any inconsistent status change in the program.</li> </ol>
16#370F	Wrong state transition : Changing the state of a single axis from Stopping to ContinuousMotion is not allowed.	<p><b>Cause:</b> After the function block is executed, the current axis cannot perform the corresponding function.</p> <p><b>Action:</b></p> <ol style="list-style-type: none"> <li>1. When this error occurs, the axis state would be in ErrorStop. And MC_Reset needs to be executed so as to make the axis back to StandStill state.</li> <li>2. Based on the status description, check whether there's any inconsistent status change in the program.</li> </ol>
16#3710	Wrong state transition : Changing the state of a single axis from Stopping to Homing is not allowed.	<p><b>Cause:</b> After the function block is executed, the current axis cannot perform the corresponding function.</p> <p><b>Action:</b></p> <ol style="list-style-type: none"> <li>1. When this error occurs, the axis state would be in ErrorStop. And MC_Reset needs to be executed so as to make the axis back to StandStill state.</li> <li>2. Based on the status description, check whether there's any inconsistent status change in the program.</li> </ol>
16#3711	Wrong state transition : Changing the state of a single axis from Stopping to CoordinatedHalt is not allowed.	<p><b>Cause:</b> After the function block is executed, the current axis cannot perform the corresponding function.</p> <p><b>Action:</b></p> <ol style="list-style-type: none"> <li>1. When this error occurs, the axis state would be in ErrorStop. And MC_Reset needs to be executed so as to make the axis back to StandStill state.</li> <li>2. Based on the status description, check whether there's any inconsistent status change in the program.</li> </ol>
16#3712	Wrong state transition : Changing the state of a single axis from Stopping to Coordinated is not allowed.	<p><b>Cause:</b> After the function block is executed, the current axis cannot perform the corresponding function.</p> <p><b>Action:</b></p> <ol style="list-style-type: none"> <li>1. When this error occurs, the axis state would be in ErrorStop. And MC_Reset needs to be executed so as to make the axis back to StandStill state.</li> <li>2. Based on the status description, check whether there's any inconsistent status change in the program.</li> </ol>

Error Code	Description	Corrective action
16#3713	Wrong state transition : Changing the state of a single axis from Stopping to CoordinatedStop is not allowed.	<p><b>Cause:</b> After the function block is executed, the current axis cannot perform the corresponding function.</p> <p><b>Action:</b></p> <ol style="list-style-type: none"> <li>1. When this error occurs, the axis state would be in ErrorStop. And MC_Reset needs to be executed so as to make the axis back to StandStill state.</li> <li>2. Based on the status description, check whether there's any inconsistent status change in the program.</li> </ol>
16#3714	Wrong state transition : Changing the state of a single axis from Homing to DiscreteMotion is not allowed.	<p><b>Cause:</b> After the function block is executed, the current axis cannot perform the corresponding function.</p> <p><b>Action:</b></p> <ol style="list-style-type: none"> <li>1. When this error occurs, the axis state would be in ErrorStop. And MC_Reset needs to be executed so as to make the axis back to StandStill state.</li> <li>2. Based on the status description, check whether there's any inconsistent status change in the program.</li> </ol>
16#3715	Wrong state transition : Changing the state of a single axis from Homing to SynchronizedMotion is not allowed.	<p><b>Cause:</b> After the function block is executed, the current axis cannot perform the corresponding function.</p> <p><b>Action:</b></p> <ol style="list-style-type: none"> <li>1. When this error occurs, the axis state would be in ErrorStop. And MC_Reset needs to be executed so as to make the axis back to StandStill state.</li> <li>2. Based on the status description, check whether there's any inconsistent status change in the program.</li> </ol>
16#3716	Wrong state transition : Changing the state of a single axis from Homing to ContinuousMotion is not allowed.	<p><b>Cause:</b> After the function block is executed, the current axis cannot perform the corresponding function.</p> <p><b>Action:</b></p> <ol style="list-style-type: none"> <li>1. When this error occurs, the axis state would be in ErrorStop. And MC_Reset needs to be executed so as to make the axis back to StandStill state.</li> <li>2. Based on the status description, check whether there's any inconsistent status change in the program.</li> </ol>
16#3717	Wrong state transition : Changing the state of a single axis from Homing to CoordinatedHalt is not allowed.	<p><b>Cause:</b> After the function block is executed, the current axis cannot perform the corresponding function.</p> <p><b>Action:</b></p> <ol style="list-style-type: none"> <li>1. When this error occurs, the axis state would be in ErrorStop. And MC_Reset needs to be executed so as to make the axis back to StandStill state.</li> <li>2. Based on the status description, check whether there's any inconsistent status change in the program.</li> </ol>
16#3718	Wrong state transition : Changing the state of a single axis from Homing to Coordinated is not allowed.	<p><b>Cause:</b> After the function block is executed, the current axis cannot perform the corresponding function.</p> <p><b>Action:</b></p> <ol style="list-style-type: none"> <li>1. When this error occurs, the axis state would be in ErrorStop. And MC_Reset needs to be executed so as to make the axis back to StandStill state.</li> <li>2. Based on the status description, check whether there's any inconsistent status change in the program.</li> </ol>

Error Code	Description	Corrective action
16#3719	Wrong state transition : Changing the state of a single axis from Homing to CoordinatedStop is not allowed.	<p><b>Cause:</b> After the function block is executed, the current axis cannot perform the corresponding function.</p> <p><b>Action:</b></p> <ol style="list-style-type: none"> <li>1. When this error occurs, the axis state would be in ErrorStop. And MC_Reset needs to be executed so as to make the axis back to StandStill state.</li> <li>2. Based on the status description, check whether there's any inconsistent status change in the program.</li> </ol>
16#371A	Wrong state transition : Changing the state of a single axis from Standstill to CoordinatedHalt is not allowed.	<p><b>Cause:</b> After the function block is executed, the current axis cannot perform the corresponding function.</p> <p><b>Action:</b></p> <ol style="list-style-type: none"> <li>1. When this error occurs, the axis state would be in ErrorStop. And MC_Reset needs to be executed so as to make the axis back to StandStill state.</li> <li>2. Based on the status description, check whether there's any inconsistent status change in the program.</li> </ol>
16#371B	Wrong state transition : Changing the state of a single axis from Standstill to CoordinatedStop is not allowed.	<p><b>Cause:</b> After the function block is executed, the current axis cannot perform the corresponding function.</p> <p><b>Action:</b></p> <ol style="list-style-type: none"> <li>1. When this error occurs, the axis state would be in ErrorStop. And MC_Reset needs to be executed so as to make the axis back to StandStill state.</li> <li>2. Based on the status description, check whether there's any inconsistent status change in the program.</li> </ol>
16#371C	Wrong state transition : Changing the state of a single axis from Errorstop to DiscreteMotion is not allowed.	<p><b>Cause:</b> After the function block is executed, the current axis cannot perform the corresponding function.</p> <p><b>Action:</b></p> <ol style="list-style-type: none"> <li>1. When this error occurs, the axis state would be in ErrorStop. And MC_Reset needs to be executed so as to make the axis back to StandStill state.</li> <li>2. Based on the status description, check whether there's any inconsistent status change in the program.</li> </ol>
16#371D	Wrong state transition : Changing the state of a single axis from Errorstop to SynchronizedMotion is not allowed.	<p><b>Cause:</b> After the function block is executed, the current axis cannot perform the corresponding function.</p> <p><b>Action:</b></p> <ol style="list-style-type: none"> <li>1. When this error occurs, the axis state would be in ErrorStop. And MC_Reset needs to be executed so as to make the axis back to StandStill state.</li> <li>2. Based on the status description, check whether there's any inconsistent status change in the program.</li> </ol>
16#371E	Wrong state transition : Changing the state of a single axis from Errorstop to ContinuousMotion is not allowed.	<p><b>Cause:</b> After the function block is executed, the current axis cannot perform the corresponding function.</p> <p><b>Action:</b></p> <ol style="list-style-type: none"> <li>1. When this error occurs, the axis state would be in ErrorStop. And MC_Reset needs to be executed so as to make the axis back to StandStill state.</li> <li>2. Based on the status description, check whether there's any inconsistent status change in the program.</li> </ol>

Error Code	Description	Corrective action
16#371F	Wrong state transition : Changing the state of a single axis from Errorstop to Stopping is not allowed.	<p><b>Cause:</b> After the function block is executed, the current axis cannot perform the corresponding function.</p> <p><b>Action:</b></p> <ol style="list-style-type: none"> <li>1. When this error occurs, the axis state would be in ErrorStop. And MC_Reset needs to be executed so as to make the axis back to StandStill state.</li> <li>2. Based on the status description, check whether there's any inconsistent status change in the program.</li> </ol>
16#3720	Wrong state transition : Changing the state of a single axis from Errorstop to Homing is not allowed.	<p><b>Cause:</b> After the function block is executed, the current axis cannot perform the corresponding function.</p> <p><b>Action:</b></p> <ol style="list-style-type: none"> <li>1. When this error occurs, the axis state would be in ErrorStop. And MC_Reset needs to be executed so as to make the axis back to StandStill state.</li> <li>2. Based on the status description, check whether there's any inconsistent status change in the program.</li> </ol>
16#3721	Wrong state transition : Changing the state of a single axis from Errorstop to CoordinatedHalt is not allowed.	<p><b>Cause:</b> After the function block is executed, the current axis cannot perform the corresponding function.</p> <p><b>Action:</b></p> <ol style="list-style-type: none"> <li>1. When this error occurs, the axis state would be in ErrorStop. And MC_Reset needs to be executed so as to make the axis back to StandStill state.</li> <li>2. Based on the status description, check whether there's any inconsistent status change in the program.</li> </ol>
16#3722	Wrong state transition : Changing the state of a single axis from Errorstop to Coordinated is not allowed.	<p><b>Cause:</b> After the function block is executed, the current axis cannot perform the corresponding function.</p> <p><b>Action:</b></p> <ol style="list-style-type: none"> <li>1. When this error occurs, the axis state would be in ErrorStop. And MC_Reset needs to be executed so as to make the axis back to StandStill state.</li> <li>2. Based on the status description, check whether there's any inconsistent status change in the program.</li> </ol>
16#3723	Wrong state transition : Changing the state of a single axis from Errorstop to CoordinatedStop is not allowed.	<p><b>Cause:</b> After the function block is executed, the current axis cannot perform the corresponding function.</p> <p><b>Action:</b></p> <ol style="list-style-type: none"> <li>1. When this error occurs, the axis state would be in ErrorStop. And MC_Reset needs to be executed so as to make the axis back to StandStill state.</li> <li>2. Based on the status description, check whether there's any inconsistent status change in the program.</li> </ol>
16#3724	Wrong state transition : Changing the state of a single axis from Disabled to DiscreteMotion is not allowed.	<p><b>Cause:</b> After the function block is executed, the current axis cannot perform the corresponding function.</p> <p><b>Action:</b></p> <ol style="list-style-type: none"> <li>1. When this error occurs, the axis state would be in ErrorStop. And MC_Reset needs to be executed so as to make the axis back to StandStill state.</li> <li>2. Based on the status description, check whether there's any inconsistent status change in the program.</li> </ol>

Error Code	Description	Corrective action
16#3725	Wrong state transition : Changing the state of a single axis from Disabled to SynchronizedMotion is not allowed.	<p><b>Cause:</b> After the function block is executed, the current axis cannot perform the corresponding function.</p> <p><b>Action:</b></p> <ol style="list-style-type: none"> <li>1. When this error occurs, the axis state would be in ErrorStop. And MC_Reset needs to be executed so as to make the axis back to StandStill state.</li> <li>2. Based on the status description, check whether there's any inconsistent status change in the program.</li> </ol>
16#3726	Wrong state transition : Changing the state of a single axis from Disabled to ContinuousMotion is not allowed.	<p><b>Cause:</b> After the function block is executed, the current axis cannot perform the corresponding function.</p> <p><b>Action:</b></p> <ol style="list-style-type: none"> <li>1. When this error occurs, the axis state would be in ErrorStop. And MC_Reset needs to be executed so as to make the axis back to StandStill state.</li> <li>2. Based on the status description, check whether there's any inconsistent status change in the program.</li> </ol>
16#3727	Wrong state transition : Changing the state of a single axis from Disabled to Stopping is not allowed.	<p><b>Cause:</b> After the function block is executed, the current axis cannot perform the corresponding function.</p> <p><b>Action:</b></p> <ol style="list-style-type: none"> <li>1. When this error occurs, the axis state would be in ErrorStop. And MC_Reset needs to be executed so as to make the axis back to StandStill state.</li> <li>2. Based on the status description, check whether there's any inconsistent status change in the program.</li> </ol>
16#3728	Wrong state transition : Changing the state of a single axis from Disabled to Homing is not allowed.	<p><b>Cause:</b> After the function block is executed, the current axis cannot perform the corresponding function.</p> <p><b>Action:</b></p> <ol style="list-style-type: none"> <li>1. When this error occurs, the axis state would be in ErrorStop. And MC_Reset needs to be executed so as to make the axis back to StandStill state.</li> <li>2. Based on the status description, check whether there's any inconsistent status change in the program.</li> </ol>
16#3729	Wrong state transition : Changing the state of a single axis from Disabled to CoordinatedHalt is not allowed.	<p><b>Cause:</b> After the function block is executed, the current axis cannot perform the corresponding function.</p> <p><b>Action:</b></p> <ol style="list-style-type: none"> <li>1. When this error occurs, the axis state would be in ErrorStop. And MC_Reset needs to be executed so as to make the axis back to StandStill state.</li> <li>2. Based on the status description, check whether there's any inconsistent status change in the program.</li> </ol>
16#372A	Wrong state transition : Changing the state of a single axis from Disabled to Coordinated is not allowed.	<p><b>Cause:</b> After the function block is executed, the current axis cannot perform the corresponding function.</p> <p><b>Action:</b></p> <ol style="list-style-type: none"> <li>1. When this error occurs, the axis state would be in ErrorStop. And MC_Reset needs to be executed so as to make the axis back to StandStill state.</li> <li>2. Based on the status description, check whether there's any inconsistent status change in the program.</li> </ol>

Error Code	Description	Corrective action
16#372B	Wrong state transition : Changing the state of a single axis from Disabled to CoordinatedStop is not allowed.	<p><b>Cause:</b> After the function block is executed, the current axis cannot perform the corresponding function.</p> <p><b>Action:</b></p> <ol style="list-style-type: none"> <li>1. When this error occurs, the axis state would be in ErrorStop. And MC_Reset needs to be executed so as to make the axis back to StandStill state.</li> <li>2. Based on the status description, check whether there's any inconsistent status change in the program.</li> </ol>
16#372C	Wrong state transition : Changing the state of a single axis from CoordinatedHalt to DiscreteMotion is not allowed.	<p><b>Cause:</b> After the function block is executed, the current axis cannot perform the corresponding function.</p> <p><b>Action:</b></p> <ol style="list-style-type: none"> <li>1. When this error occurs, the axis state would be in ErrorStop. And MC_Reset needs to be executed so as to make the axis back to StandStill state.</li> <li>2. Based on the status description, check whether there's any inconsistent status change in the program.</li> </ol>
16#372D	Wrong state transition : Changing the state of a single axis from CoordinatedHalt to SynchronizedMotion is not allowed.	<p><b>Cause:</b> After the function block is executed, the current axis cannot perform the corresponding function.</p> <p><b>Action:</b></p> <ol style="list-style-type: none"> <li>1. When this error occurs, the axis state would be in ErrorStop. And MC_Reset needs to be executed so as to make the axis back to StandStill state.</li> <li>2. Based on the status description, check whether there's any inconsistent status change in the program.</li> </ol>
16#372E	Wrong state transition : Changing the state of a single axis from CoordinatedHalt to ContinuousMotion is not allowed.	<p><b>Cause:</b> After the function block is executed, the current axis cannot perform the corresponding function.</p> <p><b>Action:</b></p> <ol style="list-style-type: none"> <li>1. When this error occurs, the axis state would be in ErrorStop. And MC_Reset needs to be executed so as to make the axis back to StandStill state.</li> <li>2. Based on the status description, check whether there's any inconsistent status change in the program.</li> </ol>
16#372F	Wrong state transition : Changing the state of a single axis from CoordinatedHalt to Stopping is not allowed.	<p><b>Cause:</b> After the function block is executed, the current axis cannot perform the corresponding function.</p> <p><b>Action:</b></p> <ol style="list-style-type: none"> <li>1. When this error occurs, the axis state would be in ErrorStop. And MC_Reset needs to be executed so as to make the axis back to StandStill state.</li> <li>2. Based on the status description, check whether there's any inconsistent status change in the program.</li> </ol>
16#3730	Wrong state transition : Changing the state of a single axis from CoordinatedHalt to Homing is not allowed.	<p><b>Cause:</b> After the function block is executed, the current axis cannot perform the corresponding function.</p> <p><b>Action:</b></p> <ol style="list-style-type: none"> <li>1. When this error occurs, the axis state would be in ErrorStop. And MC_Reset needs to be executed so as to make the axis back to StandStill state.</li> <li>2. Based on the status description, check whether there's any inconsistent status change in the program.</li> </ol>

Error Code	Description	Corrective action
16#3731	Wrong state transition : Changing the state of a single axis from CoordinatedHalt to Standstill is not allowed.	<p><b>Cause:</b> After the function block is executed, the current axis cannot perform the corresponding function.</p> <p><b>Action:</b></p> <ol style="list-style-type: none"> <li>1. When this error occurs, the axis state would be in ErrorStop. And MC_Reset needs to be executed so as to make the axis back to StandStill state.</li> <li>2. Based on the status description, check whether there's any inconsistent status change in the program.</li> </ol>
16#3732	Wrong state transition : Changing the state of a single axis from CoordinatedHalt to Errorstop is not allowed.	<p><b>Cause:</b> After the function block is executed, the current axis cannot perform the corresponding function.</p> <p><b>Action:</b></p> <ol style="list-style-type: none"> <li>1. When this error occurs, the axis state would be in ErrorStop. And MC_Reset needs to be executed so as to make the axis back to StandStill state.</li> <li>2. Based on the status description, check whether there's any inconsistent status change in the program.</li> </ol>
16#3733	Wrong state transition : Changing the state of a single axis from CoordinatedHalt to Disable is not allowed.	<p><b>Cause:</b> After the function block is executed, the current axis cannot perform the corresponding function.</p> <p><b>Action:</b></p> <ol style="list-style-type: none"> <li>1. When this error occurs, the axis state would be in ErrorStop. And MC_Reset needs to be executed so as to make the axis back to StandStill state.</li> <li>2. Based on the status description, check whether there's any inconsistent status change in the program.</li> </ol>
16#3734	Wrong state transition : Changing the state of a single axis from CoordinatedHalt to CoordinatedStop is not allowed.	<p><b>Cause:</b> After the function block is executed, the current axis cannot perform the corresponding function.</p> <p><b>Action:</b></p> <ol style="list-style-type: none"> <li>1. When this error occurs, the axis state would be in ErrorStop. And MC_Reset needs to be executed so as to make the axis back to StandStill state.</li> <li>2. Based on the status description, check whether there's any inconsistent status change in the program.</li> </ol>
16#3735	Wrong state transition : Changing the state of a single axis from Coordinated to DiscreteMotion is not allowed.	<p><b>Cause:</b> After the function block is executed, the current axis cannot perform the corresponding function.</p> <p><b>Action:</b></p> <ol style="list-style-type: none"> <li>1. When this error occurs, the axis state would be in ErrorStop. And MC_Reset needs to be executed so as to make the axis back to StandStill state.</li> <li>2. Based on the status description, check whether there's any inconsistent status change in the program.</li> </ol>
16#3736	Wrong state transition : Changing the state of a single axis from Coordinated to SynchronizedMotion is not allowed.	<p><b>Cause:</b> After the function block is executed, the current axis cannot perform the corresponding function.</p> <p><b>Action:</b></p> <ol style="list-style-type: none"> <li>1. When this error occurs, the axis state would be in ErrorStop. And MC_Reset needs to be executed so as to make the axis back to StandStill state.</li> <li>2. Based on the status description, check whether there's any inconsistent status change in the program.</li> </ol>

Error Code	Description	Corrective action
16#3737	Wrong state transition : Changing the state of a single axis from Coordinated to ContinuousMotion is not allowed.	<p><b>Cause:</b> After the function block is executed, the current axis cannot perform the corresponding function.</p> <p><b>Action:</b></p> <ol style="list-style-type: none"> <li>1. When this error occurs, the axis state would be in ErrorStop. And MC_Reset needs to be executed so as to make the axis back to StandStill state.</li> <li>2. Based on the status description, check whether there's any inconsistent status change in the program.</li> </ol>
16#3738	Wrong state transition : Changing the state of a single axis from Coordinated to Stopping is not allowed.	<p><b>Cause:</b> After the function block is executed, the current axis cannot perform the corresponding function.</p> <p><b>Action:</b></p> <ol style="list-style-type: none"> <li>1. When this error occurs, the axis state would be in ErrorStop. And MC_Reset needs to be executed so as to make the axis back to StandStill state.</li> <li>2. Based on the status description, check whether there's any inconsistent status change in the program.</li> </ol>
16#3739	Wrong state transition : Changing the state of a single axis from Coordinated to Homing is not allowed.	<p><b>Cause:</b> After the function block is executed, the current axis cannot perform the corresponding function.</p> <p><b>Action:</b></p> <ol style="list-style-type: none"> <li>1. When this error occurs, the axis state would be in ErrorStop. And MC_Reset needs to be executed so as to make the axis back to StandStill state.</li> <li>2. Based on the status description, check whether there's any inconsistent status change in the program.</li> </ol>
16#373A	Wrong state transition : Changing the state of a single axis from Coordinated to Errorstop is not allowed.	<p><b>Cause:</b> After the function block is executed, the current axis cannot perform the corresponding function.</p> <p><b>Action:</b></p> <ol style="list-style-type: none"> <li>1. When this error occurs, the axis state would be in ErrorStop. And MC_Reset needs to be executed so as to make the axis back to StandStill state.</li> <li>2. Based on the status description, check whether there's any inconsistent status change in the program.</li> </ol>
16#373B	Wrong state transition : Changing the state of a single axis from Coordinated to Disable is not allowed.	<p><b>Cause:</b> After the function block is executed, the current axis cannot perform the corresponding function.</p> <p><b>Action:</b></p> <ol style="list-style-type: none"> <li>1. When this error occurs, the axis state would be in ErrorStop. And MC_Reset needs to be executed so as to make the axis back to StandStill state.</li> <li>2. Based on the status description, check whether there's any inconsistent status change in the program.</li> </ol>
16#373C	Wrong state transition : Changing the state of a single axis from CoordinatedStop to DiscreteMotion is not allowed.	<p><b>Cause:</b> After the function block is executed, the current axis cannot perform the corresponding function.</p> <p><b>Action:</b></p> <ol style="list-style-type: none"> <li>1. When this error occurs, the axis state would be in ErrorStop. And MC_Reset needs to be executed so as to make the axis back to StandStill state.</li> <li>2. Based on the status description, check whether there's any inconsistent status change in the program.</li> </ol>



Error Code	Description	Corrective action
16#373D	Wrong state transition : Changing the state of a single axis from CoordinatedStop to SynchronizedMotion is not allowed.	<p><b>Cause:</b> After the function block is executed, the current axis cannot perform the corresponding function.</p> <p><b>Action:</b></p> <ol style="list-style-type: none"> <li>1. When this error occurs, the axis state would be in ErrorStop. And MC_Reset needs to be executed so as to make the axis back to StandStill state.</li> <li>2. Based on the status description, check whether there's any inconsistent status change in the program.</li> </ol>
16#373E	Wrong state transition : Changing the state of a single axis from CoordinatedStop to ContinuousMotion is not allowed.	<p><b>Cause:</b> After the function block is executed, the current axis cannot perform the corresponding function.</p> <p><b>Action:</b></p> <ol style="list-style-type: none"> <li>1. When this error occurs, the axis state would be in ErrorStop. And MC_Reset needs to be executed so as to make the axis back to StandStill state.</li> <li>2. Based on the status description, check whether there's any inconsistent status change in the program.</li> </ol>
16#373F	Wrong state transition : Changing the state of a single axis from CoordinatedStop to Stopping is not allowed.	<p><b>Cause:</b> After the function block is executed, the current axis cannot perform the corresponding function.</p> <p><b>Action:</b></p> <ol style="list-style-type: none"> <li>1. When this error occurs, the axis state would be in ErrorStop. And MC_Reset needs to be executed so as to make the axis back to StandStill state.</li> <li>2. Based on the status description, check whether there's any inconsistent status change in the program.</li> </ol>
16#3740	Wrong state transition : Changing the state of a single axis from CoordinatedStop to Homing is not allowed.	<p><b>Cause:</b> After the function block is executed, the current axis cannot perform the corresponding function.</p> <p><b>Action:</b></p> <ol style="list-style-type: none"> <li>1. When this error occurs, the axis state would be in ErrorStop. And MC_Reset needs to be executed so as to make the axis back to StandStill state.</li> <li>2. Based on the status description, check whether there's any inconsistent status change in the program.</li> </ol>
16#3741	Wrong state transition : Changing the state of a single axis from CoordinatedStop to Standstill is not allowed.	<p><b>Cause:</b> After the function block is executed, the current axis cannot perform the corresponding function.</p> <p><b>Action:</b></p> <ol style="list-style-type: none"> <li>1. When this error occurs, the axis state would be in ErrorStop. And MC_Reset needs to be executed so as to make the axis back to StandStill state.</li> <li>2. Based on the status description, check whether there's any inconsistent status change in the program.</li> </ol>
16#3742	Wrong state transition : Changing the state of a single axis from CoordinatedStop to Errorstop is not allowed.	<p><b>Cause:</b> After the function block is executed, the current axis cannot perform the corresponding function.</p> <p><b>Action:</b></p> <ol style="list-style-type: none"> <li>1. When this error occurs, the axis state would be in ErrorStop. And MC_Reset needs to be executed so as to make the axis back to StandStill state.</li> <li>2. Based on the status description, check whether there's any inconsistent status change in the program.</li> </ol>

Error Code	Description	Corrective action
16#3743	Wrong state transition : Changing the state of a single axis from CoordinatedStop to Disable is not allowed.	<p><b>Cause:</b> After the function block is executed, the current axis cannot perform the corresponding function.</p> <p><b>Action:</b></p> <ol style="list-style-type: none"> <li>1. When this error occurs, the axis state would be in ErrorStop. And MC_Reset needs to be executed so as to make the axis back to StandStill state.</li> <li>2. Based on the status description, check whether there's any inconsistent status change in the program.</li> </ol>
16#3744	Wrong state transition : Changing the state of a single axis from CoordinatedStop to Homing is not allowed.	<p><b>Cause:</b> After the function block is executed, the current axis cannot perform the corresponding function.</p> <p><b>Action:</b></p> <ol style="list-style-type: none"> <li>1. When this error occurs, the axis state would be in ErrorStop. And MC_Reset needs to be executed so as to make the axis back to StandStill state.</li> <li>2. Based on the status description, check whether there's any inconsistent status change in the program.</li> </ol>
16#3770	Wrong state transition : The axis group state is GroupStopping while executing function blocks concerning linear and rotary movement.	<p><b>Cause:</b> After the function block is executed, the current axis cannot perform the corresponding function.</p> <p><b>Action:</b></p> <ol style="list-style-type: none"> <li>1 When this error occurs, the axis group state would be <b>GroupErrorStop</b> and the single axis state would be <b>CoordinatedHalt</b>. Execute <b>DFB_GroupReset</b> to make the axis group state back to <b>Standby</b> and the single axis state is <b>Coordinated</b> for the continued use of the axis group.</li> <li>2. Based on the status description, check whether there's any inconsistent status change in the program.</li> </ol>
16#3771	Wrong state transition : Execute two DFB_GroupStop function blocks and StopMode of the second DFB_GroupStop is set to HALT.	<p><b>Cause:</b> After the function block is executed, the current axis cannot perform the corresponding function.</p> <p><b>Action:</b></p> <ol style="list-style-type: none"> <li>1 When this error occurs, the axis group state would be <b>GroupErrorStop</b> and the single axis state would be <b>CoordinatedHalt</b>. Execute <b>DFB_GroupReset</b> to make the axis group state back to <b>Standby</b> and the single axis state is <b>Coordinated</b> for the continued use of the axis group.</li> <li>2. Based on the status description, check whether there's any inconsistent status change in the program.</li> </ol>
16#3772	Wrong state transition : Execute DFB_GroupStop function blocks and the axis group state is GroupErrorStop.	<p><b>Cause:</b> After the function block is executed, the current axis cannot perform the corresponding function.</p> <p><b>Action:</b></p> <ol style="list-style-type: none"> <li>1 When this error occurs, the axis group state would be <b>GroupErrorStop</b> and the single axis state would be <b>CoordinatedHalt</b>. Execute <b>DFB_GroupReset</b> to make the axis group state back to <b>Standby</b> and the single axis state is <b>Coordinated</b> for the continued use of the axis group.</li> <li>2. Based on the status description, check whether there's any inconsistent status change in the program.</li> </ol>

Error Code	Description	Corrective action
16#3773	Wrong state transition : When DFB_GroupStop function block is executed, StopMode is HALT and an error occurs to a single axis in the group.	<p><b>Cause:</b> After the function block is executed, the current axis cannot perform the corresponding function.</p> <p><b>Action:</b></p> <ol style="list-style-type: none"> <li>1 When this error occurs, the axis group state would be <b>GroupErrorStop</b> and the single axis state would be <b>CoordinatedHalt</b>. Execute <b>DFB_GroupReset</b> to make the axis group state back to <b>Standby</b> and the single axis state is <b>Coordinated</b> for the continued use of the axis group.</li> <li>2. Based on the status description, check whether there's any inconsistent status change in the program.</li> </ol>
16#3774	Wrong state transition : When DFB_GroupStop function block is executed, StopMode is STOP and an error occurs to a single axis in the group.	<p><b>Cause:</b> After the function block is executed, the current axis cannot perform the corresponding function.</p> <p><b>Action:</b></p> <ol style="list-style-type: none"> <li>1 When this error occurs, the axis group state would be <b>GroupErrorStop</b> and the single axis state would be <b>CoordinatedHalt</b>. Execute <b>DFB_GroupReset</b> to make the axis group state back to <b>Standby</b> and the single axis state is <b>Coordinated</b> for the continued use of the axis group.</li> <li>2. Based on the status description, check whether there's any inconsistent status change in the program.</li> </ol>
16#3775	Wrong state transition : When DFB_GroupStop function block is executed, StopMode is HALT and Done is ON. But the axis group state is GroupErrorStop.	<p><b>Cause:</b> After the function block is executed, the current axis cannot perform the corresponding function.</p> <p><b>Action:</b></p> <ol style="list-style-type: none"> <li>1 When this error occurs, the axis group state would be <b>GroupErrorStop</b> and the single axis state would be <b>CoordinatedHalt</b>. Execute <b>DFB_GroupReset</b> to make the axis group state back to <b>Standby</b> and the single axis state is <b>Coordinated</b> for the continued use of the axis group.</li> <li>2. Based on the status description, check whether there's any inconsistent status change in the program.</li> </ol>
16#3776	Wrong state transition : The axis group state is GroupMoving.	<p><b>Cause:</b> After the function block is executed, the current axis cannot perform the corresponding function.</p> <p><b>Action:</b></p> <ol style="list-style-type: none"> <li>1 When this error occurs, the axis group state would be <b>GroupErrorStop</b> and the single axis state would be <b>CoordinatedHalt</b>. Execute <b>DFB_GroupReset</b> to make the axis group state back to <b>Standby</b> and the single axis state is <b>Coordinated</b> for the continued use of the axis group.</li> <li>2. Based on the status description, check whether there's any inconsistent status change in the program.</li> </ol>
16#3777	Wrong state transition : When DFB_GroupDisable function block is executed, the axis group state is GroupMoving.	<p><b>Cause:</b> After the function block is executed, the current axis cannot perform the corresponding function.</p> <p><b>Action:</b></p> <ol style="list-style-type: none"> <li>1 When this error occurs, the axis group state would be <b>GroupErrorStop</b> and the single axis state would be <b>CoordinatedHalt</b>. Execute <b>DFB_GroupReset</b> to make the axis group state back to <b>Standby</b> and the single axis state is <b>Coordinated</b> for the continued use of the axis group.</li> <li>2. Based on the status description, check whether there's any inconsistent status change in the program.</li> </ol>

Error Code	Description	Corrective action
16#3778	Wrong state transition : When DFB_GroupDisable function block is executed, the axis group state is GroupStopping.	<p><b>Cause:</b> After the function block is executed, the current axis cannot perform the corresponding function.</p> <p><b>Action:</b></p> <ol style="list-style-type: none"> <li>1 When this error occurs, the axis group state would be <b>GroupErrorStop</b> and the single axis state would be <b>CoordinatedHalt</b>. Execute <b>DFB_GroupReset</b> to make the axis group state back to <b>Standby</b> and the single axis state is <b>Coordinated</b> for the continued use of the axis group.</li> <li>2. Based on the status description, check whether there's any inconsistent status change in the program.</li> </ol>
16#3780	Wrong state transition : The single axis state is not SynchronizedMotion	<p><b>Cause:</b> After the function block is executed, the current axis cannot perform the corresponding function.</p> <p><b>Action:</b></p> <ol style="list-style-type: none"> <li>1. When this error occurs, the axis state would be in ErrorStop. And MC_Reset needs to be executed so as to make the axis back to StandStill state.</li> <li>2. Based on the status description, check whether there's any inconsistent status change in the program.</li> </ol>
16#3781	Wrong state transition : The single axis state is Disabled.	<p><b>Cause:</b> After the function block is executed, the current axis cannot perform the corresponding function.</p> <p><b>Action:</b></p> <ol style="list-style-type: none"> <li>1. When this error occurs, the axis state would be in ErrorStop. And MC_Reset needs to be executed so as to make the axis back to StandStill state.</li> <li>2. Based on the status description, check whether there's any inconsistent status change in the program.</li> </ol>
16#3782	Wrong state transition : The single axis state is neither Standstill nor Homing.	<p><b>Cause:</b> After the function block is executed, the current axis cannot perform the corresponding function.</p> <p><b>Action:</b></p> <ol style="list-style-type: none"> <li>1. When this error occurs, the axis state would be in ErrorStop. And MC_Reset needs to be executed so as to make the axis back to StandStill state.</li> <li>2. Based on the status description, check whether there's any inconsistent status change in the program.</li> </ol>
16#3783	Wrong state transition : The single axis state is Coordinated or CoordinatedHalt.	<p><b>Cause:</b> After the function block is executed, the current axis cannot perform the corresponding function.</p> <p><b>Action:</b></p> <ol style="list-style-type: none"> <li>1. When this error occurs, the axis state would be in ErrorStop. And MC_Reset needs to be executed so as to make the axis back to StandStill state.</li> <li>2. Based on the status description, check whether there's any inconsistent status change in the program.</li> </ol>
16#3784	Wrong state transition : The single axis state is Errorstop.	<p><b>Cause:</b> After the function block is executed, the current axis cannot perform the corresponding function.</p> <p><b>Action:</b></p> <ol style="list-style-type: none"> <li>1. When this error occurs, the axis state would be in ErrorStop. And MC_Reset needs to be executed so as to make the axis back to StandStill state.</li> <li>2. Based on the status description, check whether there's any inconsistent status change in the program.</li> </ol>
16#3800	Motion network disconnected during the execution of the instruction.	Check whether the network cable is detached or the network is disconnected.

Error Code	Description	Corrective action
16#3801	EtherCAT axis error occurs on the motion network	<b>Cause:</b> the motion axis reports an alarm or an error during the motion. <b>Action:</b> read the axis states and errors by using related function blocks, and reset the axis error by using MC_Reset.
16#3802	LSP occurs to the EtherCAT Axis	<b>Cause:</b> signal of the positive limit switch (LSP) is triggered by the slave. <b>Action:</b> clear errors with MC_Reset and make DFB_MPG back under the soft limit by using MC_MoveAbsolute, MC_MoveRelative and MC_MoveVelocity.
16#3803	LSN occurs to the EtherCAT Axis	<b>Cause:</b> signal of the negative limit switch (LSN) is triggered by the slave <b>Action:</b> clear errors with MC_Reset and make DFB_MPG back under the soft limit by using MC_MoveAbsolute, MC_MoveRelative and MC_MoveVelocity
16#3901	Failed to re-connect to the motion network.	<b>Cause:</b> After the motion network is reset, the CPU cannot re-connect to the motion network. <b>Action:</b> 1. Check whether the network cable is detached or the network is disconnected. 2. Check whether the connected servo drive is powered on.
16#3904	Motion network master can not read Slave parameters via SDO.	Check whether the parameter reading settings of Group and Parameter matches the available range of the servo drive.
16#3905	Motion network master can not write Slave parameters via SDO.	1. Check whether the parameter writing settings of Group and Parameter matches the available range of the servo drive. 2. Check whether the specified values to be written are within the available setting range for the parameters.
16#3906	Torque limit setting error in MC_SetTorqueLimit	<b>Cause:</b> the specified value for <i>PositiveValue</i> or <i>NegativeValue</i> is invalid. <b>Action:</b> Check whether the specified value for <i>PositiveValue</i> or <i>NegativeValue</i> is within available setting range of the servo drive.
16#3907	The function is not available for imaginary axes.	<b>Cause:</b> the function is not for imaginary axis. <b>Action:</b> change the imaginary axis to the real axis
16#3908	The function is not available for encoder axes.	<b>Cause:</b> the function is not for encoder axes. <b>Action:</b> change the encoder axis to a real or virtual axis.
16#3909	The motion network is currently executing other network functions.	Check the read/write status of SDO to see if the motion network is executing other network functions.
16#390C	Axis error occurs during the movement.	<b>Cause:</b> Axis error occurs during the movement. <b>Action:</b> the system will send the function block with the axis state back and users can learn what the error code is and then use MC_Rest to clear this error.

Error Code	Description	Corrective action
16#390E	Failed to change the state of EtherCAT slave to OP.	錯誤原因：切換運動網路上 EtherCAT 從站狀態至 OP 失敗 排除方式：檢查運動網路是否有脫落狀況·各從站是否有上電
16#3910	Cancel the engagement when there is no engagement.	<b>Cause:</b> not executing the mc_gearin, mc_gearinpos, mc_combineaxes, but to execute mc_gearout <b>Action:</b> when the axis does not execute mc_gearin, mc_gearinpos, mc_combineaxes, do not execute mc_gearout
16#3911	Software limit error	<b>Cause:</b> the axis reached the software limit. <b>Action:</b> use MC_Reset to clear the error and use MC_MoveAbsolute, MC_MoveRelative, MC_MoveVelocity or DFB_MPG to move the axis back to the proper range.
16#3912	The input contact of the function block exceeds the axis of rotation range	<b>Cause:</b> The input contact of the function block exceeds the axis of rotation range <b>Action:</b> modify the input to have it within the axis of rotation range
16#3913	Synchronization for engagement fails	<b>Cause:</b> before completing the engagement, the velocity of the main axis has changed <b>Action:</b> before completing the engagement, do not change the velocity of the main axis
16#3914	GearInPos velocity is set too small	<b>Cause:</b> maximum velocity of GearInPos has set too small <b>Action:</b> set a bigger maximum velocity
16#3915	GearInPos jerk is set too small	<b>Cause:</b> maximum jerk of GearInPos has set too small <b>Action:</b> set a bigger maximum jerk
16#3916	GearInPos engagement time is set too small	<b>Cause:</b> GearInPos engagement time too short <b>Action:</b> increase the MasterStartDistance
16#3917	GearInPos the velocity of the main axis is 0 when the engagement started	<b>Cause:</b> GearInPos the velocity of the main axis is 0 when the engagement started <b>Action:</b> not to set the velocity of the main axis 0
16#3918	The engagement velocity is larger than the AxisVelocityMax	<b>Cause:</b> The engagement velocity is larger than the AxisVelocityMax <b>Action:</b> modify the maximum of the axis velocity
16#3919	GearInPos the main axis moves in opposite direction	<b>Cause:</b> GearInPos the main axis moves in opposite direction <b>Action:</b> make the main axis and the auxiliary axis move in the same direction
16#3920	GearInPos acceleration is set too small	<b>Cause:</b> the acceleration or deceleration is set too small <b>Action:</b> increase the acceleration or deceleration
16#3921	GearInPosMasterStartDist out of range	<b>Cause:</b> MasterStartDist setting out of range <b>Action:</b> check the starting and ending position of the engagement

Error Code	Description	Corrective action
16#3922	GearInPos slave synchnoization position is set too small	<b>Cause:</b> SlaveSyncPosition is set too small <b>Action:</b> increase the setting value of SlaveSyncPosition, or increase the acceleration or deceleration
16#3923	GearInPos slave synchnoization position is set too big	<b>Cause:</b> SlaveSyncPosition is set too big <b>Action:</b> decrease the setting value of SlaveSyncPosition, or increase the acceleration or deceleration
16#3924	GearInPos the velocity of the main axis changes when the engagement started	<b>Cause:</b> before InSync, the velocity of the main axis changes <b>Action:</b> before InSync, fix the velocity of the main axis
16#3950	Capture cannot be used when the pulse speed is over 1MHz	<b>Cause:</b> Capture cannot be used when the pulse speed is over 1MHz <b>Action:</b> slow dow to capture the pulse speed and restart the function block
16#3951	DFB_CamCurve2 setting error	<b>Cause:</b> CamCurve2 input error (e.g. if Concatenate is not True, or other input parameters are out of range) <b>Action:</b> 1. Turn the PLC off and then on, execute the DFB_CamCurve2 and first set concatenate option to False. When the function block is Done, set the concatenate to True and then execute the DFB_CamCurve2 to clear the error. Check other parameters for any errors.
16#3953	Capture2 uses the same channel number repeatedly	<b>Cause:</b> more than two groups of DFB_Capture2 use the same channel number <b>Action:</b> use other un-used channel number instead
16#3954	Torque ramp fail to write	<b>Cause:</b> TorqueRamp is set to 0. <b>Action:</b> TorqueRamp cannot be set as 0.
16#3955	Torque velocity fail to write	<b>Cause:</b> MC_TorqueControl value is not supported by the servo <b>Action:</b> check the servo manual to see the supported setting range
16#3956	The maximum pulse velocity at Compare or Capture Source is greater than 1MHz.	<b>Cause:</b> the maximum operating frequency is greater than 1MHz with the specified source. <b>Action:</b> reset axis parameters and make the maximum operating frequency less than 1MHz.
16#3957	The actual position and the current position in Compare are not synchronized.	<b>Cause:</b> the actual position and the current position in Compare are not synchronized. <b>Action:</b> change the PLC state from Run to Stop again so as to synchronize the current position.
16#3958	The current position and Capture position are not synchronized.	<b>Cause:</b> the actual position and the current position in Capture are not synchronized. <b>Action:</b> change the PLC state from Run to Stop again so as to synchronize the current position.
16#3959	Delta parameter setting error	<b>Cause:</b> Delta parameter setting error <b>Action:</b> reset Delta parameters.
16#3960	The specified server or slave devices are not supported.	<b>Cause:</b> unsupported server or slave devices <b>Action:</b> specify the supported server or slave devices.

Error Code	Description	Corrective action
16#3961	The specified storage devices are not supported.	<b>Cause:</b> unsupported storage devices <b>Action:</b> specify the supported storage devices.
16#3962	DFB_HCnt of the master axis has not been activated.	<b>Cause:</b> DFB_HCnt of the master axis has not been activated. <b>Action:</b> activate DFB_HCnt of the master axis first.
16#3A00	CAM table setting error	<b>Cause:</b> the designated CAM Table is not existed. <b>Action:</b> add a newCAM Table or set up a new setting in an existed CAM Table
16#3A01	CamIn master setting error	<b>Cause:</b> setting error in the source of the master axis <b>Action:</b> set up the source of the master axis again
16#3A02	CamIn CAM table changed too soon	<b>Cause:</b> CamIn change to another CAM table when the one started has not finished <b>Action:</b> enable the CAM function again
16#3A03	CamIn activation mode setting exceeds the available range	<b>Cause:</b> Activation Mode is not 0 or 1 <b>Action:</b> set up the setting vale and restart the CAM funciton
16#3A04	CamIn start mode setting exceeds the available range	<b>Cause:</b> CAM Start Mode setting value is not within the range 0~3 <b>Action:</b> set the CAM Start Mode value in the range
16#3A05	CamIn master scaling is set to 0.0	<b>Cause:</b> CAM Master Scaling is set to 0 <b>Action:</b> set the Master Scaling to a value other than 0 and restart CAM again
16#3A06	CamIn slave scaling is set to 0.0	<b>Cause:</b> CAM Slave Scaling is set to 0 <b>Action:</b> set the Slave Scaling to a value other than 0 and restart CAM
16#3A07	CamIn MasterSyncPosition setting error	<b>Cause:</b> Cam MasterSyncPosition is set smaller than 0 <b>Action:</b> set the MasterSyncPosition to a value equal to or greater than 0 and restart Cam
16#3A08	CamIn ActivationPosition setting error	<b>Cause:</b> Cam ActivationPosition setting value is out of range <b>Action:</b> set the ActivationPosition value within setting range and restart Cam
16#3A10	CamIn Master Start Position set too low	<b>Cause:</b> Cam Master Start Positon is set too low <b>Action:</b> set the Start Position value bigger and restart Cam
16#3A11	CamIn starts engaging and the velocity of the main axis changes	<b>Cause:</b> when Cam starts to engage, the main axis acceleration is not 0 <b>Action:</b> set the main axis in the engagement area to uniform motion and restart Cam
16#3A12	CamIn Start Mode velocity setting too small.	<b>Cause:</b> Cam Start Mode velocity is too small <b>Action:</b> set the velocity to a bigger value and restart Cam
16#3A13	CamIn the velocity is set too small.	<b>Cause:</b> CAM Start Mode velocity is set too small <b>Action:</b> set the velocity to a bigger value and restart CAM



Error Code	Description	Corrective action
16#3A14	The required CamIn engagement time in Start Mode is too short.	<b>Cause:</b> The required CamIn engagement time in Start Mode is too short. <b>Action:</b> postpone the time to engage.
16#3A15	CamIn jerk is set too small	<b>Cause:</b> the jerk for the CAM Start Mode is set too small <b>Action:</b> set the jerk value to a bigger value and restart CAM
16#3A16	CamIn maximum acceleration is set too small	<b>Cause:</b> CAM Start Mode maximum acceleration is set too small <b>Action:</b> set the maximum acceleration to a bigger value and restart CAM
16#3A17	CamIn Start mode distance is set too small	<b>Cause:</b> CAM Start Mode distance is set too small <b>Action:</b> set the Sync Position to a bigger value and restart CAM
16#3A18	CamIn Start mode distance is set too large	<b>Cause:</b> CAM Start Mode distance is set too large <b>Action:</b> set the Sync Position to a smaller value and restart CAM
16#3A19	Too many CamIn are wait to start	<b>Cause:</b> more than 5 sets of CAMs are waiting to start on the same axis <b>Action:</b> do not start all 5 CAMs at the same time
16#3A20	Master is moving in the negative direction.	<b>Cause:</b> Master is moving in the negative direction while the slave is in the middle of the CAM movement. <b>Action:</b> use MC_Reset to clear error
16#3A21	CamIn is cancelled when it is not in "CamIn" state.	<b>Cause:</b> designated Slave axis is not in "CamIn" state. <b>Action:</b> use MC_Reset to clear error
16#3A30	The available number of times to apply DFB_SaveCamTable has been fully used.	<b>Cause:</b> run out the available number of times to apply DFB_SaveCamTable <b>Action:</b> reboot the device to apply DFB_SaveCamTable.
16#3C00	Flash is executing other writing actions.	<b>Cause:</b> Flash is executing other writing actions. <b>Action:</b> re-execute after other tasks in Flash are done.
16#3D00	EtherCAT ENI file does not match current hardware configuration.	<b>Cause:</b> EtherCAT ENI file in the system does not match current EtherCAT configuration. <b>Action:</b> download again the ENI file that matches current EtherCAT configuration.
16#3D01	Slave lost in motoin network	<b>Cause:</b> slave lost during the motion network communication. <b>Action:</b> reconnect to the motion netowrk
16#3D03	EtherCAT DC time is set too small	<b>Cause:</b> EtherCAT DC time setting error 8-axis minimum 500us; 16-axis minimum 1000us; 32-axis minimum 2000us <b>Action:</b> check the current axis number and set up the DC time again

Error Code	Description	Corrective action
16#3D05	Servo parameter file does not exist.	<p><b>Cause:</b> the file is lost while restoring the servo parameters.</p> <p><b>Action:</b></p> <ol style="list-style-type: none"> <li>1. If the file is saved in the SD card, backup servo parameters again after checking the card status</li> <li>2. Check whether parameter backup has been performed.</li> </ol>
16#3E00	OD : 0x6098 HOMING_METHOD download error	<p><b>Cause:</b> the error might relate to <b>MC_HOME</b> function block, please check the detailed error codes of the Nth axis parameters (axis_n.Read_ECAT_SDO_ErrorCode).</p> <p><b>Action:</b> refer to the detailed error codes of the Nth axis (axis_n.Read_ECAT_SDO_ErrorCode) and troubleshoot the error.</p>
16#3E01	OD : 0x6099 (subidx : 1) HOMING_SPEEDS (HOMEING_SPEED_DURING_SEARCH_FOR_SWITCH) download error	<p><b>Cause:</b> the error might relate to <b>MC_HOME</b> function block, please check the detailed error codes of the Nth axis parameters (axis_n.Read_ECAT_SDO_ErrorCode).</p> <p><b>Action:</b> refer to the detailed error codes of the Nth axis (axis_n.Read_ECAT_SDO_ErrorCode) and troubleshoot the error.</p>
16#3E02	OD : 0x6099 (subidx : 2) HOMING_SPEEDS (HOMEING_SPEED_DURING_SEARCH_FOR_ZERO) download error	<p><b>Cause:</b> the error might relate to <b>MC_HOME</b> function block, please check the detailed error codes of the Nth axis parameters (axis_n.Read_ECAT_SDO_ErrorCode).</p> <p><b>Action:</b> refer to the detailed error codes of the Nth axis (axis_n.Read_ECAT_SDO_ErrorCode) and troubleshoot the error.</p>
16#3E03	OD : 0x609A HOMING_ACC download error	<p><b>Cause:</b> the error might relate to <b>MC_HOME</b> function block, please check the detailed error codes of the Nth axis parameters (axis_n.Read_ECAT_SDO_ErrorCode).</p> <p><b>Action:</b> refer to the detailed error codes of the Nth axis (axis_n.Read_ECAT_SDO_ErrorCode) and troubleshoot the error.</p>
16#3E04	OD : 0x607C HOME_OFFSET download error	<p><b>Cause:</b> the error might relate to <b>MC_HOME</b> function block, please check the detailed error codes of the Nth axis parameters (axis_n.Read_ECAT_SDO_ErrorCode).</p> <p><b>Action:</b> refer to the detailed error codes of the Nth axis (axis_n.Read_ECAT_SDO_ErrorCode) and troubleshoot the error.</p>
16#3E05	OD : 0x605A QUICK_STOP_OPTION_CODE download error	<p><b>Cause:</b> the error might relate to <b>MC_HOME</b> function block, please check the detailed error codes of the Nth axis parameters (axis_n.Read_ECAT_SDO_ErrorCode).</p> <p><b>Action:</b> refer to the detailed error codes of the Nth axis (axis_n.Read_ECAT_SDO_ErrorCode) and troubleshoot the error.</p>

Error Code	Description	Corrective action
16#3E06	OD : 0x6085 QUICK_STOP_DEC download error	<p><b>Cause:</b> the error might relate to <b>MC_HOME</b> function block, please check the detailed error codes of the Nth axis parameters (axis_n.Read_ECAT_SDO_ErrorCode).</p> <p><b>Action:</b> refer to the detailed error codes of the Nth axis (axis_n.Read_ECAT_SDO_ErrorCode) and troubleshoot the error.</p>
16#3E07	OD : 0x6087 TORQUE_SLOPE download error	<p><b>Cause:</b> the error might relate to <b>MC_TorqueControl</b> function block, please check the detailed error codes of the Nth axis parameters (axis_n.Read_ECAT_SDO_ErrorCode).</p> <p><b>Action:</b> refer to the detailed error codes of the Nth axis (axis_n.Read_ECAT_SDO_ErrorCode) and troubleshoot the error.</p>
16#3E08	OD : 0x6087 TORQUE_SLOPE upload error	<p><b>Cause:</b> the error might relate to <b>MC_TorqueControl</b> function block, please check the detailed error codes of the Nth axis parameters (axis_n.Read_ECAT_SDO_ErrorCode).</p> <p><b>Action:</b> refer to the detailed error codes of the Nth axis (axis_n.Read_ECAT_SDO_ErrorCode) and troubleshoot the error.</p>
16#3E09	OD : 0x607F MAX_PROFILE_VELOCITY download error	<p><b>Cause:</b> the error might relate to <b>MC_TorqueControl</b> function block, please check the detailed error codes of the Nth axis parameters (axis_n.Read_ECAT_SDO_ErrorCode).</p> <p><b>Action:</b> refer to the detailed error codes of the Nth axis (axis_n.Read_ECAT_SDO_ErrorCode) and troubleshoot the error.</p>
16#3E0A	OD : 0x607F MAX_PROFILE_VELOCITY upload error	<p><b>Cause:</b> the error might relate to <b>MC_TorqueControl</b> function block, please check the detailed error codes of the Nth axis parameters (axis_n.Read_ECAT_SDO_ErrorCode).</p> <p><b>Action:</b> refer to the detailed error codes of the Nth axis (axis_n.Read_ECAT_SDO_ErrorCode) and troubleshoot the error.</p>
16#3E0B	OD : 0x2001 ASDA servo panel error code P0-01 upload error	<p><b>Cause:</b> please check the detailed error codes of the Nth axis parameters (axis_n.Read_ECAT_SDO_ErrorCode).</p> <p><b>Action:</b> refer to the detailed error codes of the Nth axis (axis_n.Read_ECAT_SDO_ErrorCode) and troubleshoot the error.</p>

Error Code	Description	Corrective action
16#3E0C	OD : 0x603F servo error codes upload error	<b>Cause:</b> please check the detailed error codes of the Nth axis parameters (axis_n.Read_ECAT_SDO_ErrorCode). <b>Action:</b> refer to the detailed error codes of the Nth axis (axis_n.Read_ECAT_SDO_ErrorCode) and troubleshoot the error.
16#3E0D	OD : 0x212C ASDA e-cam gear ratio parameters download error	<b>Cause:</b> the error might relate to ASDA-A2 e-cam gear ratio parameter <b>P1-44</b> , please check the detailed error codes of the Nth axis parameters (axis_n.Read_ECAT_SDO_ErrorCode). <b>Action:</b> refer to the detailed error codes of the Nth axis (axis_n.Read_ECAT_SDO_ErrorCode) and troubleshoot the error.
16#3E0E	OD : 0x212C ASDA e-cam gear ratio parameters P1-44 upload error	<b>Cause:</b> the error might relate to ASDA-A2 e-cam gear ratio parameter <b>P1-44</b> , please check the detailed error codes of the Nth axis parameters (axis_n.Read_ECAT_SDO_ErrorCode). <b>Action:</b> refer to the detailed error codes of the Nth axis (axis_n.Read_ECAT_SDO_ErrorCode) and troubleshoot the error.
16#3E0F	OD : 0x212C ASDA e-cam gear ratio parameters P1-45 download error	<b>Cause:</b> the error might relate to ASDA-A2 e-cam gear ratio parameter <b>P1-45</b> , please check the detailed error codes of the Nth axis parameters (axis_n.Read_ECAT_SDO_ErrorCode). <b>Action:</b> refer to the detailed error codes of the Nth axis (axis_n.Read_ECAT_SDO_ErrorCode) and troubleshoot the error.
16#3E10	OD : 0x212C ASDA e-cam gear ratio parameters P1-45 upload error	<b>Cause:</b> the error might relate to ASDA-A2 e-cam gear ratio parameter <b>P1-45</b> , please check the detailed error codes of the Nth axis parameters (axis_n.Read_ECAT_SDO_ErrorCode). <b>Action:</b> refer to the detailed error codes of the Nth axis (axis_n.Read_ECAT_SDO_ErrorCode) and troubleshoot the error.
16#3E11	OD : 0x230C ASDA latched parameter P3-12 download error	<b>Cause:</b> the error might relate to ASDA-A2 latched parameter <b>P3-12</b> , please check the detailed error codes of the Nth axis parameters (axis_n.Read_ECAT_SDO_ErrorCode). <b>Action:</b> refer to the detailed error codes of the Nth axis (axis_n.Read_ECAT_SDO_ErrorCode) and troubleshoot the error.

Error Code	Description	Corrective action
16#3E12	OD : 0x230C ASDA latched parameter P3-12 upload error	<p><b>Cause:</b> the error might relate to ASDA-A2 latched parameter <b>P3-12</b>, please check the detailed error codes of the Nth axis parameters (axis_n.Read_ECAT_SDO_ErrorCode).</p> <p><b>Action:</b> refer to the detailed error codes of the Nth axis (axis_n.Read_ECAT_SDO_ErrorCode) and troubleshoot the error.</p>
16#3E13	OD : 0x60E0 POSITIVE_TORQUE_LIMIT_VALUE download error	<p><b>Cause:</b> the error might relate to <b>MC_SetTorqueLimit</b> function block, please check the detailed error codes of the Nth axis parameters (axis_n.Read_ECAT_SDO_ErrorCode).</p> <p><b>Action:</b> refer to the detailed error codes of the Nth axis (axis_n.Read_ECAT_SDO_ErrorCode) and troubleshoot the error.</p>
16#3E14	OD : 0x60E0 POSITIVE_TORQUE_LIMIT_VALUE upload error	<p><b>Cause:</b> the error might relate to <b>MC_SetTorqueLimit</b> function block, please check the detailed error codes of the Nth axis parameters (axis_n.Read_ECAT_SDO_ErrorCode).</p> <p><b>Action:</b> refer to the detailed error codes of the Nth axis (axis_n.Read_ECAT_SDO_ErrorCode) and troubleshoot the error.</p>
16#3E15	OD : 0x60E1 NEGATIVE_TORQUE_LIMIT_VALUE download error	<p><b>Cause:</b> the error might relate to <b>MC_SetTorqueLimit</b> function block, please check the detailed error codes of the Nth axis parameters (axis_n.Read_ECAT_SDO_ErrorCode).</p> <p><b>Action:</b> refer to the detailed error codes of the Nth axis (axis_n.Read_ECAT_SDO_ErrorCode) and troubleshoot the error.</p>
16#3E16	OD : 0x60E1 NEGATIVE_TORQUE_LIMIT_VALUE upload error	<p><b>Cause:</b> the error might relate to <b>MC_SetTorqueLimit</b> function block, please check the detailed error codes of the Nth axis parameters (axis_n.Read_ECAT_SDO_ErrorCode).</p> <p><b>Action:</b> refer to the detailed error codes of the Nth axis (axis_n.Read_ECAT_SDO_ErrorCode) and troubleshoot the error.</p>
16#3E17	OD : 0x6072 MAX_TORQUE download error	<p><b>Cause:</b> the error might relate to <b>MC_SetTorqueLimit</b> function block, please check the detailed error codes of the Nth axis parameters (axis_n.Read_ECAT_SDO_ErrorCode).</p> <p><b>Action:</b> refer to the detailed error codes of the Nth axis (axis_n.Read_ECAT_SDO_ErrorCode) and troubleshoot the error.</p>

Error Code	Description	Corrective action
16#3E18	OD : 0x6072 MAX_TORQUE upload error	<b>Cause:</b> the error might relate to <b>MC_SetTorqueLimit</b> function block, please check the detailed error codes of the Nth axis parameters (axis_n.Read_ECAT_SDO_ErrorCode). <b>Action:</b> refer to the detailed error codes of the Nth axis (axis_n.Read_ECAT_SDO_ErrorCode) and troubleshoot the error.
16#6001	Illegal IP address (SM1107)	<ol style="list-style-type: none"> <li>1. Check the program and the related special data registers.</li> <li>2. Set the Ethernet parameter for the CPU module in HWCONFIG again.</li> </ol>
16#6002	Illegal netmask address	<ol style="list-style-type: none"> <li>1. Check the program and the related special data registers.</li> <li>2. Set the Ethernet parameter for the CPU module in HWCONFIG again.</li> </ol>
16#6003	Illegal gateway mask	<ol style="list-style-type: none"> <li>1. Check the program and the related special data registers.</li> <li>2. Set the Ethernet parameter for the CPU module in HWCONFIG again.</li> </ol>
16#6004	The IP address filter is set incorrectly.	Set the Ethernet parameter for the CPU module in HWCONFIG again.
16#6006	The static ARP table is set incorrectly.	Set the Ethernet parameter for the CPU module in HWCONFIG again.
16#6108	Outgoing mail server validation error	Check if the account and password are correct so as to reset the Ethernet parameter settings of the CPU module in HWCONFIG.
16#6111	The specified E-mail address does not exist.	<ol style="list-style-type: none"> <li>1. Check whether the E-mail address is correct.</li> <li>2. Reset Ethernet parameters of the CPU module in HWCONFIG.</li> </ol>
16#6200	The remote IP address for TCP socket is not correct.	<ol style="list-style-type: none"> <li>1. Perform program check as well as related SR.</li> <li>2. Reset Ethernet parameters of the CPU module in HWCONFIG.</li> </ol>
16#6209	The remote IP address in UDP socket is not correct.	<ol style="list-style-type: none"> <li>1. Perform program check as well as related SR.</li> <li>2. Reset Ethernet parameters of the CPU module in HWCONFIG.</li> </ol>
16#6300	Ether Link can only be applied to M, D, L devices.	Check the Ether Link device in NWCONFIG and download it again.
16#6301	Ether Link device address setting exceeds the valid range.	Check whether the Ether Link device in NWCONFIG is supported by the PLC.
16#6302	The data length of Ether Link exceeds the limit.	Check whether the Ether Link device in NWCONFIG is supported by the PLC.

Error Code	Description	Corrective action
16#6305	Nodes in Ether Link commands is different from the local nodes.	Check Ether Link devices in NWCONFIG and download again.
16#630A	The ID and other settings of the module are different from settings in Ether Link.	1. Check module parameter settings (HWCONFIG). 2. Check Ether Link settings (NWCONFIG).
16#630B	Netmask setting of CPU or modules is different from Ether Link settings.	1. Check module parameter settings (HWCONFIG). 2. Check Ether Link settings (NWCONFIG).
16#6500	Initialized data exchange error	Check whether the connection number of Ether Link and Data Exchange exceeds the system specification, then download again.
16#6602	Node numbers exceed the limit.	Check network deployment parameters in NWCONFIG and download again.
16#6603	The device is not defined.	Check network deployment parameters in NWCONFIG and download again.
16#8242	Gcode Data ERROR	1. Use ISPSOft to download Gcode again
16#8243	ECAM Data ERROR	1. Use ISPSOft to download internal E-CAM again
16#8244	ENI Data ERROR	1. Use ECAT Builder to download the Ethernet parameter again
16#8245	EtherCat Data ERROR	1. Use ECAT Builder to download the Ethernet parameter again
16#8246	Axes Parameters Data ERROR	1. Use ISPSOft to download axes parameters again
16#8247	External Gcode Data ERROR	1. Make sure the SD card is installed and use ISPSOft to download the external Gcode

### 9.3.3. BUS FAULT Indicator ON

The BUS FAULT indicator on the CPU would be ON to indicate an error on CPU, or to indicate an error on I/O module together with the ERROR indicator on an I/O module. If an error occurs in an I/O module, the status of the BUS FAULT indicator on the CPU will be the same as that of the ERROR indicator on the I/O module. If multiple errors occur in the I/O modules, the BUS FAULT indicator on the CPU will keep ON (not blinking). For example, if the ERROR indicator on module A is ON and the ERROR indicator on module B blinks, the BUS FAULT indicator will keep ON. When the error in I/O module A is cleared, module B will blink and the BUS FAULT indicator will blink as well. Refer to the section 9.4 for more information about the indicator behaviors of each module.

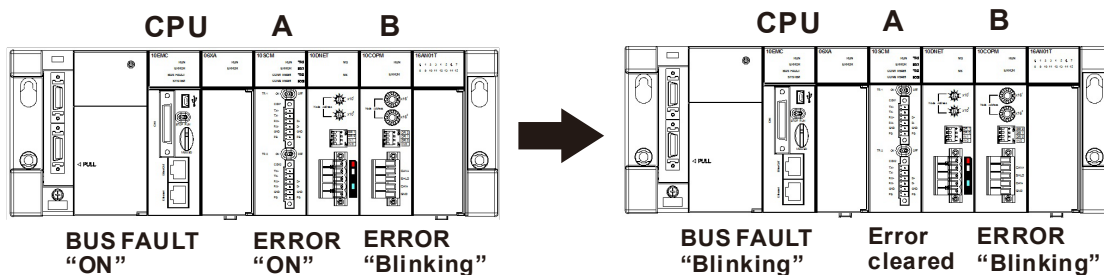

You can get the corrective actions for the CPU errors indicated by the BUS FAULT indicator from the table below. If the error code you obtained is not listed in the table below, you can check if an error occurs on the I/O modules. Refer to the following content of this section for more information about the troubleshooting for I/O modules.

Error Code	Description	Corrective action
16#0013	The I/O module can not run/stop. (SM10)	Check whether the setting of the parameter for the module is correct. If the setting is correct, please check whether the module breaks down. If the error still occurs, please contact the manufacturer.
16#0014	The procedure of restoring the system can not be executed. (SM9)	The contents of the system backup file are incorrect, or the file does not exist in the path specified. If the file exists and the procedure of restoring the system can not be executed, please backing up the system again. If the error still occurs, please contact the manufacturer.
16#1401	An error occurs when the data in the I/O module is accessed. (SM9)	Please contact the factory.
16#1402	The actual arrangement of the I/O modules is not consistent with the module table. (SM9)	Check whether the module table in HWCONFIG is consistent with the actual arrangement of the I/O modules.
16#1403	An error occurs when the data is read from the module. (SM9)	Check whether the module operates normally. If the error still occurs, please contact the factory.
16#1405	The setting parameter of the module is not found. (SM9)	Set the parameter in HWCONFIG again, and download it.
16#140B	The number of network modules exceeds the limit. (SM9)	Please decrease the number of network modules to the number supported by the system.
16#140C	The checksum of the high-speed data exchange is incorrect	Please check the version of the firmware installed on the module, and contact the factory.
16#140D	The ID of the actual power supply module is not the same as the ID of the power supply module set in HWCONFIG.	Check whether the power supply configuration in HWCONFIG is consistent with the actual arrangement of the power supply module.
16#140E	The amount of data exchanged at a high speed exceeds the maximum amount supported.	Check the firmware version and contact the supplier.
16#140F	High-speed data exchange error	Check the firmware version and contact the supplier.
16#A010	The module is in RUN state while receiving data from the PLC.	Reset EMC module parameters in HWCONFIG and download them again. If the error still exists, please contact the original manufacturer.
16#A402	Miscompare LRC when the PLC sends data to the module.	Reset EMC module parameters in HWCONFIG and download them again. If the error still exists, please contact the original manufacturer.



Error Code	Description	Corrective action
16#A801	The PLC sends data to the module with incorrect function codes.	Reset EMC module parameters in HWCONFIG and download them again. If the error still exists, please contact the original manufacturer.
16#A803	The PLC sends data to the module with incorrect commands of function codes.	Reset EMC module parameters in HWCONFIG and download them again. If the error still exists, please contact the original manufacturer.
16#A805	The length of data sent from the PLC exceeds the limit.	Reset EMC module parameters in HWCONFIG and download them again. If the error still exists, please contact the original manufacturer.
16#A808	Module data read errors occur while the PLC sending data to the module.	Reset EMC module parameters in HWCONFIG and download them again. If the error still exists, please contact the original manufacturer.

### 9.3.4. BUS FAULT Indicator Blinking

If the BUS FAULT indicator blinks, check the operating state of the module. Refer to section 9.4 for more information about the indicators behaviors of each module, and refer to the following content of this section for more information about the troubleshooting for I/O modules.

Error Code	Description	Corrective action
16#4001	An error occurs to the first axis in the module.	<p>The reason for errors: An error occurs to the first axis in the module.</p> <ol style="list-style-type: none"> <li>1. This error code is an axis error in the module which is displayed in the CPU system errors.</li> <li>2. CPU is able to clear errors by itself, but if the error still exists, the same error code would be shown again.</li> </ol> <p>Troubleshooting: Remove the axis error and the blinking error light would be turned off. Then you are allowed to remove this system error in the CPU.</p>
16#4002	An error occurs to the second axis in the module.	<p>The reason for errors: An error occurs to the second axis in the module.</p> <ol style="list-style-type: none"> <li>1. This error code is an axis error in the module which is displayed in the CPU system errors.</li> <li>2. CPU is able to clear errors by itself, but if the error still exists, the same error code would be shown again.</li> </ol> <p>Troubleshooting: Remove the axis error and the blinking error light would be turned off. Then you are allowed to remove this system error in the CPU.</p>

Error Code	Description	Corrective action
16#4003	An error occurs to the third axis in the module.	<p>The reason for errors: An error occurs to the third axis in the module.</p> <ol style="list-style-type: none"> <li>1. This error code is an axis error in the module which is displayed in the CPU system errors.</li> <li>2. CPU is able to clear errors by itself, but if the error still exists, the same error code would be shown again.</li> </ol> <p>Troubleshooting: Remove the axis error and the blinking error light would be turned off. Then you are allowed to remove this system error in the CPU.</p>
16#4004	An error occurs to the 4th axis in the module.	<p>The reason for errors: An error occurs to the 4th axis in the module.</p> <ol style="list-style-type: none"> <li>1. This error code is an axis error in the module which is displayed in the CPU system errors.</li> <li>2. CPU is able to clear errors by itself, but if the error still exists, the same error code would be shown again.</li> </ol> <p>Troubleshooting: Remove the axis error and the blinking error light would be turned off. Then you are allowed to remove this system error in the CPU.</p>
16#4005	An error occurs to the 5th axis in the module.	<p>The reason for errors: An error occurs to the 5th axis in the module.</p> <ol style="list-style-type: none"> <li>1. This error code is an axis error in the module which is displayed in the CPU system errors.</li> <li>2. CPU is able to clear errors by itself, but if the error still exists, the same error code would be shown again.</li> </ol> <p>Troubleshooting: Remove the axis error and the blinking error light would be turned off. Then you are allowed to remove this system error in the CPU.</p>
16#4006	An error occurs to the 6th axis in the module.	<p>The reason for errors: An error occurs to the 6th axis in the module.</p> <ol style="list-style-type: none"> <li>1. This error code is an axis error in the module which is displayed in the CPU system errors.</li> <li>2. CPU is able to clear errors by itself, but if the error still exists, the same error code would be shown again.</li> </ol> <p>Troubleshooting: Remove the axis error and the blinking error light would be turned off. Then you are allowed to remove this system error in the CPU.</p>
16#4007	An error occurs to the 7th axis in the module.	<p>The reason for errors: An error occurs to the 7th axis in the module.</p> <ol style="list-style-type: none"> <li>1. This error code is an axis error in the module which is displayed in the CPU system errors.</li> <li>2. CPU is able to clear errors by itself, but if the error still exists, the same error code would be shown again.</li> </ol> <p>Troubleshooting: Remove the axis error and the blinking error light would be turned off. Then you are allowed to remove this system error in the CPU.</p>

Error Code	Description	Corrective action
16#4008	An error occurs to the 8th axis in the module.	<p>The reason for errors: An error occurs to the 8th axis in the module.</p> <ol style="list-style-type: none"> <li>1. This error code is an axis error in the module which is displayed in the CPU system errors.</li> <li>2. CPU is able to clear errors by itself, but if the error still exists, the same error code would be shown again.</li> </ol> <p>Troubleshooting: Remove the axis error and the blinking error light would be turned off. Then you are allowed to remove this system error in the CPU.</p>
16#4009	An error occurs to the 9th axis in the module.	<p>The reason for errors: An error occurs to the 9th axis in the module.</p> <ol style="list-style-type: none"> <li>1. This error code is an axis error in the module which is displayed in the CPU system errors.</li> <li>2. CPU is able to clear errors by itself, but if the error still exists, the same error code would be shown again.</li> </ol> <p>Troubleshooting: Remove the axis error and the blinking error light would be turned off. Then you are allowed to remove this system error in the CPU.</p>
16#400A	An error occurs to the 10th axis in the module.	<p>The reason for errors: An error occurs to the 10th axis in the module.</p> <ol style="list-style-type: none"> <li>1. This error code is an axis error in the module which is displayed in the CPU system errors.</li> <li>2. CPU is able to clear errors by itself, but if the error still exists, the same error code would be shown again.</li> </ol> <p>Troubleshooting: Remove the axis error and the blinking error light would be turned off. Then you are allowed to remove this system error in the CPU.</p>
16#400B	An error occurs to the 11th axis in the module.	<p>The reason for errors: An error occurs to the 11th axis in the module.</p> <ol style="list-style-type: none"> <li>1. This error code is an axis error in the module which is displayed in the CPU system errors.</li> <li>2. CPU is able to clear errors by itself, but if the error still exists, the same error code would be shown again.</li> </ol> <p>Troubleshooting: Remove the axis error and the blinking error light would be turned off. Then you are allowed to remove this system error in the CPU.</p>
16#400C	An error occurs to the 12th axis in the module.	<p>The reason for errors: An error occurs to the 12th axis in the module.</p> <ol style="list-style-type: none"> <li>1. This error code is an axis error in the module which is displayed in the CPU system errors.</li> <li>2. CPU is able to clear errors by itself, but if the error still exists, the same error code would be shown again.</li> </ol> <p>Troubleshooting: Remove the axis error and the blinking error light would be turned off. Then you are allowed to remove this system error in the CPU.</p>

Error Code	Description	Corrective action
16#400D	An error occurs to the 13th axis in the module.	<p>The reason for errors: An error occurs to the 13th axis in the module.</p> <ol style="list-style-type: none"> <li>1. This error code is an axis error in the module which is displayed in the CPU system errors.</li> <li>2. CPU is able to clear errors by itself, but if the error still exists, the same error code would be shown again.</li> </ol> <p>Troubleshooting: Remove the axis error and the blinking error light would be turned off. Then you are allowed to remove this system error in the CPU.</p>
16#400E	An error occurs to the 14th axis in the module.	<p>The reason for errors: An error occurs to the 14th axis in the module.</p> <ol style="list-style-type: none"> <li>1. This error code is an axis error in the module which is displayed in the CPU system errors.</li> <li>2. CPU is able to clear errors by itself, but if the error still exists, the same error code would be shown again.</li> </ol> <p>Troubleshooting: Remove the axis error and the blinking error light would be turned off. Then you are allowed to remove this system error in the CPU.</p>
16#400F	An error occurs to the 15th axis in the module.	<p>The reason for errors: An error occurs to the 15th axis in the module.</p> <ol style="list-style-type: none"> <li>1. This error code is an axis error in the module which is displayed in the CPU system errors.</li> <li>2. CPU is able to clear errors by itself, but if the error still exists, the same error code would be shown again.</li> </ol> <p>Troubleshooting: Remove the axis error and the blinking error light would be turned off. Then you are allowed to remove this system error in the CPU.</p>
16#4010	An error occurs to the 16th axis in the module.	<p>The reason for errors: An error occurs to the 16th axis in the module.</p> <ol style="list-style-type: none"> <li>1. This error code is an axis error in the module which is displayed in the CPU system errors.</li> <li>2. CPU is able to clear errors by itself, but if the error still exists, the same error code would be shown again.</li> </ol> <p>Troubleshooting: Remove the axis error and the blinking error light would be turned off. Then you are allowed to remove this system error in the CPU.</p>
16#4011	An error occurs to the 17th axis in the module.	<p>The reason for errors: An error occurs to the 17th axis in the module.</p> <ol style="list-style-type: none"> <li>1. This error code is an axis error in the module which is displayed in the CPU system errors.</li> <li>2. CPU is able to clear errors by itself, but if the error still exists, the same error code would be shown again.</li> </ol> <p>Troubleshooting: Remove the axis error and the blinking error light would be turned off. Then you are allowed to remove this system error in the CPU.</p>

Error Code	Description	Corrective action
16#4012	An error occurs to the 18th axis in the module.	<p>The reason for errors: An error occurs to the 18th axis in the module.</p> <ol style="list-style-type: none"> <li>1. This error code is an axis error in the module which is displayed in the CPU system errors.</li> <li>2. CPU is able to clear errors by itself, but if the error still exists, the same error code would be shown again.</li> </ol> <p>Troubleshooting: Remove the axis error and the blinking error light would be turned off. Then you are allowed to remove this system error in the CPU.</p>
16#4013	An error occurs to the 19th axis in the module.	<p>The reason for errors: An error occurs to the 19th axis in the module.</p> <ol style="list-style-type: none"> <li>1. This error code is an axis error in the module which is displayed in the CPU system errors.</li> <li>2. CPU is able to clear errors by itself, but if the error still exists, the same error code would be shown again.</li> </ol> <p>Troubleshooting: Remove the axis error and the blinking error light would be turned off. Then you are allowed to remove this system error in the CPU.</p>
16#4014	An error occurs to the 20th axis in the module.	<p>The reason for errors: An error occurs to the 20th axis in the module.</p> <ol style="list-style-type: none"> <li>1. This error code is an axis error in the module which is displayed in the CPU system errors.</li> <li>2. CPU is able to clear errors by itself, but if the error still exists, the same error code would be shown again.</li> </ol> <p>Troubleshooting: Remove the axis error and the blinking error light would be turned off. Then you are allowed to remove this system error in the CPU.</p>
16#4015	An error occurs to the 21st axis in the module.	<p>The reason for errors: An error occurs to the 21th axis in the module.</p> <ol style="list-style-type: none"> <li>1. This error code is an axis error in the module which is displayed in the CPU system errors.</li> <li>2. CPU is able to clear errors by itself, but if the error still exists, the same error code would be shown again.</li> </ol> <p>Troubleshooting: Remove the axis error and the blinking error light would be turned off. Then you are allowed to remove this system error in the CPU.</p>
16#4016	An error occurs to the 22nd axis in the module.	<p>The reason for errors: An error occurs to the 22th axis in the module.</p> <ol style="list-style-type: none"> <li>1. This error code is an axis error in the module which is displayed in the CPU system errors.</li> <li>2. CPU is able to clear errors by itself, but if the error still exists, the same error code would be shown again.</li> </ol> <p>Troubleshooting: Remove the axis error and the blinking error light would be turned off. Then you are allowed to remove this system error in the CPU.</p>

Error Code	Description	Corrective action
16#4017	An error occurs to the 23rd axis in the module.	<p>The reason for errors: An error occurs to the 23rd axis in the module.</p> <ol style="list-style-type: none"> <li>1. This error code is an axis error in the module which is displayed in the CPU system errors.</li> <li>2. CPU is able to clear errors by itself, but if the error still exists, the same error code would be shown again.</li> </ol> <p>Troubleshooting: Remove the axis error and the blinking error light would be turned off. Then you are allowed to remove this system error in the CPU.</p>
16#4018	An error occurs to the 24th axis in the module.	<p>The reason for errors: An error occurs to the 24th axis in the module.</p> <ol style="list-style-type: none"> <li>1. This error code is an axis error in the module which is displayed in the CPU system errors.</li> <li>2. CPU is able to clear errors by itself, but if the error still exists, the same error code would be shown again.</li> </ol> <p>Troubleshooting: Remove the axis error and the blinking error light would be turned off. Then you are allowed to remove this system error in the CPU.</p>
16#4019	An error occurs to the 25th axis in the module.	<p>The reason for errors: An error occurs to the 25th axis in the module.</p> <ol style="list-style-type: none"> <li>1. This error code is an axis error in the module which is displayed in the CPU system errors.</li> <li>2. CPU is able to clear errors by itself, but if the error still exists, the same error code would be shown again.</li> </ol> <p>Troubleshooting: Remove the axis error and the blinking error light would be turned off. Then you are allowed to remove this system error in the CPU.</p>
16#401A	An error occurs to the 26th axis in the module.	<p>The reason for errors: An error occurs to the 26th axis in the module.</p> <ol style="list-style-type: none"> <li>1. This error code is an axis error in the module which is displayed in the CPU system errors.</li> <li>2. CPU is able to clear errors by itself, but if the error still exists, the same error code would be shown again.</li> </ol> <p>Troubleshooting: Remove the axis error and the blinking error light would be turned off. Then you are allowed to remove this system error in the CPU.</p>
16#401B	An error occurs to the 27th axis in the module.	<p>The reason for errors: An error occurs to the 27th axis in the module.</p> <ol style="list-style-type: none"> <li>1. This error code is an axis error in the module which is displayed in the CPU system errors.</li> <li>2. CPU is able to clear errors by itself, but if the error still exists, the same error code would be shown again.</li> </ol> <p>Troubleshooting: Remove the axis error and the blinking error light would be turned off. Then you are allowed to remove this system error in the CPU.</p>

Error Code	Description	Corrective action
16#401C	An error occurs to the 28th axis in the module.	<p>The reason for errors: An error occurs to the 28th axis in the module.</p> <ol style="list-style-type: none"> <li>1. This error code is an axis error in the module which is displayed in the CPU system errors.</li> <li>2. CPU is able to clear errors by itself, but if the error still exists, the same error code would be shown again.</li> </ol> <p>Troubleshooting: Remove the axis error and the blinking error light would be turned off. Then you are allowed to remove this system error in the CPU.</p>
16#401D	An error occurs to the 29th axis in the module.	<p>The reason for errors: An error occurs to the 29th axis in the module.</p> <ol style="list-style-type: none"> <li>1. This error code is an axis error in the module which is displayed in the CPU system errors.</li> <li>2. CPU is able to clear errors by itself, but if the error still exists, the same error code would be shown again.</li> </ol> <p>Troubleshooting: Remove the axis error and the blinking error light would be turned off. Then you are allowed to remove this system error in the CPU.</p>
16#401E	An error occurs to the 30th axis in the module.	<p>The reason for errors: An error occurs to the 30th axis in the module.</p> <ol style="list-style-type: none"> <li>1. This error code is an axis error in the module which is displayed in the CPU system errors.</li> <li>2. CPU is able to clear errors by itself, but if the error still exists, the same error code would be shown again.</li> </ol> <p>Troubleshooting: Remove the axis error and the blinking error light would be turned off. Then you are allowed to remove this system error in the CPU.</p>
16#401F	An error occurs to the 31st axis in the module.	<p>The reason for errors: An error occurs to the 31st axis in the module.</p> <ol style="list-style-type: none"> <li>1. This error code is an axis error in the module which is displayed in the CPU system errors.</li> <li>2. CPU is able to clear errors by itself, but if the error still exists, the same error code would be shown again.</li> </ol> <p>Troubleshooting: Remove the axis error and the blinking error light would be turned off. Then you are allowed to remove this system error in the CPU.</p>
16#4020	An error occurs to the 32nd axis in the module.	<p>The reason for errors: An error occurs to the 32nd axis in the module.</p> <ol style="list-style-type: none"> <li>1. This error code is an axis error in the module which is displayed in the CPU system errors.</li> <li>2. CPU is able to clear errors by itself, but if the error still exists, the same error code would be shown again.</li> </ol> <p>Troubleshooting: Remove the axis error and the blinking error light would be turned off. Then you are allowed to remove this system error in the CPU.</p>

Error Code	Description	Corrective action
16#4100	An error occurred to the module.	<p>The reason for errors: An error occurs to the module.</p> <ol style="list-style-type: none"><li data-bbox="853 320 1460 383">1. This error code is an axis error in the module which is displayed in the CPU system errors.</li><li data-bbox="853 383 1460 448">2. CPU is able to clear errors by itself, but if the error still exists, the same error code would be shown again.</li></ol> <p>Troubleshooting: Remove the axis error and the blinking error light would be turned off. Then you are allowed to remove this system error in the CPU.</p>



### 9.3.5. Others

Error Code	Description	Corrective action
16#000F	The original program in the PLC is damaged.	After users compile the program again, they can download the program again.
16#0024	There is no IO module on the backplane.	Check whether the IO module is on the backplane.
16#1801	There is no interrupt service routine in the CPU module.	Check whether a corresponding interrupt service routine is created in the PLC program (24V LV Detection)
16#600B	UDP connection failed (error flag SM1091)	<ol style="list-style-type: none"> <li>1. Check the network to see if the current UDP connections exceed the limitation supported by the PLC.</li> <li>2. Try again later. (Since this error would not make the PLC shut down, you are allowed to perform corrective action by using relative flags in the program.)</li> </ol>
16#600C	TCP Socket has been used.(error flag SM1109)	<ol style="list-style-type: none"> <li>1. Check if the socket with the same number has been used in data access.</li> <li>2. Change the socket number or try again later (Since this error would make the PLC shut down, you can perform relative action in the program to troubleshoot the error.)</li> </ol>
16#600D	The RJ45 port is not connected. (error flag SM1100)	<b>Cause:</b> RJ45 prot is not connected. <b>Action:</b> check the communication cable
16#600E	The RJ45 port on AH10EN is not connected to the internet.	Please check if the Ethernet cable is connected to AH10EN properly.
16#6100	E-mail connection busy (error flag SM1113)	Try again later. (Since this error would not make the PLC shut down, you are allowed to perform corrective action by using relative flags in the program.)
16#6104	E-mail attachment does not exist	Check if the attachment file is stored in the memory card.
16#6105	E-mail attachment exceeds the capacity limit	Check if the file size of the specified attachment exceeds 2MB.
16#6201	The local port for TCP socket is not correct.	<ol style="list-style-type: none"> <li>1. Check the program and the related special data registers.</li> <li>2. Reset the Ethernet parameter for the CPU module in HWCONFIG.</li> </ol>
16#6202	The remote port for TCP socket is not correct.	<ol style="list-style-type: none"> <li>1. Check the program and the related special data registers.</li> <li>2. Reset the Ethernet parameter for the CPU module in HWCONFIG.</li> </ol>
16#6203	The IP address to send data for TCP socket is not correct.	<ol style="list-style-type: none"> <li>1. Check the program and the related special data registers.</li> <li>2. Reset the Ethernet parameter for the CPU module in HWCONFIG.</li> </ol>
16#6204	The data length of sending data for TCP socket does not meet the requirement.	<ol style="list-style-type: none"> <li>1. Check the program and the related special data registers.</li> <li>2. Reset the Ethernet parameter for the CPU module in HWCONFIG.</li> </ol>
16#6205	The data sending device for TCP socket is out of range	<ol style="list-style-type: none"> <li>1. Check the program and the related special data registers.</li> <li>2. Reset the Ethernet parameter for the CPU module in HWCONFIG.</li> </ol>
16#6206	The IP address to receive data for TCP socket is not correct.	<ol style="list-style-type: none"> <li>1. Check the program and the related special data registers.</li> <li>2. Reset the Ethernet parameter for the CPU module in HWCONFIG.</li> </ol>
16#6207	The data length of receiving data for TCP socket does not meet the requirement	<ol style="list-style-type: none"> <li>1. Check the program and the related special data registers.</li> <li>2. Reset the Ethernet parameter for the CPU module in HWCONFIG.</li> </ol>

Error Code	Description	Corrective action
16#6208	The data receiving device for TCP socket is out of range	<ol style="list-style-type: none"> <li>1. Check the program and the related special data registers.</li> <li>2. Reset the Ethernet parameter for the CPU module in HWCONFIG.</li> </ol>
16#620A	The local IP address for UDP socket is not correct.	<ol style="list-style-type: none"> <li>1. Check the program and the related special data registers.</li> <li>2. Reset the Ethernet parameter for the CPU module in HWCONFIG.</li> </ol>
16#620B	The remote port for UDP socket is not correct.	<ol style="list-style-type: none"> <li>1. Check the program and the related special data registers.</li> <li>2. Reset the Ethernet parameter for the CPU module in HWCONFIG.</li> </ol>
16#620C	The IP address to send data for UDP socket is not correct.	<ol style="list-style-type: none"> <li>1. Check the program and the related special data registers.</li> <li>2. Reset the Ethernet parameter for the CPU module in HWCONFIG.</li> </ol>
16#620D	The length of the data which needs to be sent in a UDP Socket Configuration window is illegal.	<ol style="list-style-type: none"> <li>1. Check the program and the related special data registers.</li> <li>2. Reset the Ethernet parameter for the CPU module in HWCONFIG.</li> </ol>
16#620E	The data sending device for UDP socket is out of range	<ol style="list-style-type: none"> <li>1. Check the program and the related special data registers.</li> <li>2. Reset the Ethernet parameter for the CPU module in HWCONFIG.</li> </ol>
16#620F	The IP address to receive data for UDP socket is not correct.	<ol style="list-style-type: none"> <li>1. Check the program and the related special data registers.</li> <li>2. Reset the Ethernet parameter for the CPU module in HWCONFIG.</li> </ol>
16#6210	The data length of receiving data for UDP socket does not meet the requirement	<ol style="list-style-type: none"> <li>1. Check the program and the related special data registers.</li> <li>2. Reset the Ethernet parameter for the CPU module in HWCONFIG.</li> </ol>
16#6211	The data receiving device for UDP socket is out of range	<ol style="list-style-type: none"> <li>1. Check the program and the related special data registers.</li> <li>2. Reset Ethernet parameters of CPU module in HWCONFIG.</li> </ol>
16#6212	There is no response from the remote device after the timeout period.	Make sure that the remote device is connected.
16#6213	The data received exceeds the limit.	<ol style="list-style-type: none"> <li>1. Check the program and the related special data registers.</li> <li>2. Reset the Ethernet parameter for the CPU module in HWCONFIG.</li> </ol>
16#6214	The remote device refuses the connection.	Make sure that the remote device operates normally.
16#6215	The current socket connection is closed.	Check if the design on operation procedure in the program is correct.
16#6217	The current socket connection has been opened.	Check if the design on operation procedure in the program is correct.
16#6218	Data has been sent via the current socket connection.	Check if the design on operation procedure in the program is correct.
16#6219	Data has been received via the current socket connection.	Check if the design on operation procedure in the program is correct.
16#6303	The remote device connection of Ether Link is terminated.	<ol style="list-style-type: none"> <li>1. Check the connection status and the remote device status.</li> <li>2. Check whether the remote device supports Ether Link.</li> </ol>

Error Code	Description	Corrective action
16#6304	Ether Link connection is busy.	<ol style="list-style-type: none"> <li>1. Check if there's too much connection on Ether Link and exceeds the handling capacity of the system.</li> <li>2. Retry Ether Link connection later.</li> </ol>
16#6309	Ether Link response timeout	<ol style="list-style-type: none"> <li>1. Check if the PLCs on Ether Link operate normally.</li> <li>2. Check if the connection cables between PLCs are functioning properly.</li> </ol>
16#6400	The number of TCP connections reaches the upper limit, or the flag which is related to the sending of the data is not set to ON.	<ol style="list-style-type: none"> <li>1. Check whether the flag which is related to the sending of the data in the program is modified.</li> <li>2. Retry the setting of the flag and the sending of the packet.</li> </ol>
16#6401	The remote device aborts the connection.	Check whether the remote device support the MODBUS port (502).
16#6402	There is no response from the remote device after the timeout period.	Check whether the remote device operate normally.
16#6403	The remote IP address used in the applied instruction is illegal.	Check whether the program is correct.
16#6404	The MODBUS function code not supported is received.	Check the command transmitted from the remote device.
16#6405	The number of data which will be received is not consistent with the actual length of the data.	Check the command transmitted from the remote device.
16#6501	The remote device involved in the data exchange does not respond after the timeout period. (SM828~SM955)	Check the device whose connection number corresponds to the error flag, and check whether it is connected normally.
16#6502	The remote device involved in the data exchange does not respond correctly. (SM828~SM955)	Check the device whose connection number corresponds to the error flag, and check whether it is connected normally.
16#6600	The network number to receive commands exceeds the valid range.	Check the command sent from the remote device.
16#6601	The network is not defined in the network parameters.	Check the network deployment in NWCONFIG and download it again.
16#6604	There's no available routing to be connected.	Data packet would be sent later (Since this error would not make the PLC shut down, you are allowed to perform corrective action by using relative flags in the program.)
16#6605	An unexpected packet has been received.	Check the command sent from the remote device.
16#6606	Routing response timeout	<ol style="list-style-type: none"> <li>1. Check the network deployment in NWCONFIG.</li> <li>2. Check if the communication timeout conforms to the actual applications.</li> </ol>
16#6700	MODBUS TCP data exchange initialization error	Check the setting value and download the data again.

Error Code	Description	Corrective action
16#6701	MODBUS TCP data exchange timeout	Confirm if the device to be connected supports MODBUS communication protocol.
16#6702	MODBUS TCP data receiving error	Confirm if the device to be connected supports MODBUS communication protocol.
16#7002	This function is not available for CPU modules.	Check the CPU firmware version.
16#7203	Invalid access code	Check the content of the packet sent by the device to be connected.
16#7204	Incorrect CPU module port number	Please check the command setting values.
16#7401	Function code error	Check the content of the packet sent by the device to be connected.
16#7402	The packet exceeds the max. data length.	Check the content of the packet sent by the device to be connected.
16#7407	Non-ASCII characters exist in the command.	Check the content of the packet sent by the device to be connected.
16#7408	PLC is in RUN mode	Data download for program or CPU parameters is not allowed when PLC is in RUN mode.
16#740A	The CPU memory is being written or failed to be written.	Flash/SD card is being written. Please try again later.
16#740B	The Clear or Reset operation is in progress.	The RST/CLR operation is in progress. Please try again later.
16#740C	The backplane number in a communication command is incorrect.	Please check the PLC firmware and the software version and contact the supplier.
16#740D	The slot number in a communication command is incorrect.	Please check the PLC firmware and the software version and contact the supplier.
16#740E	Error occurs when clearing the memory	Please try again. If the error occurs again, contact the supplier.
16#740F	Communication timeout	Check if the device to be connected is in normal operation.
16#7410	The received Function Code doesn't match the current Function Code.	Check the packet content sent by the remote device.
16#7412	Data cannot be downloaded to CPU because SW1 is ON.	Confirm that SW1 is OFF.
16#757D	The number of times users can enter the PLC password is 0.	The password retry limit is reached. Please power on the PLC again.
16#757E	Incorrect PLC password	Check if the password is correct.

Error Code	Description	Corrective action
16#8105	The contents of the program downloaded are incorrect. The program syntax is incorrect.	Download the program again.
16#8106	The contents of the program downloaded are incorrect. The length of the execution code exceeds the limit.	Download the program again.
16#8107	The contents of the program downloaded are incorrect. The length of the source code exceeds the limit.	Download the program again.
16#8114	Failed to backup or restore servo parameters.	Check the backup or restore process.
16#8230	The CPU parameter downloaded is incorrect. The IP address is illegal.	Check the network related parameter which is downloaded to the CPU.
16#8231	The CPU parameter downloaded is incorrect. The netmask address is illegal.	Check the network related parameter which is downloaded to the CPU.
16#8232	The CPU parameter downloaded is incorrect. The gateway address is illegal.	Check the network related parameter which is downloaded to the CPU.
16#8233	The CPU parameter downloaded is incorrect. The IP address filter is set incorrectly.	Check the network related parameter which is downloaded to the CPU.
16#8235	The CPU parameter downloaded is incorrect. The static ARP table is set incorrectly.	1. Check the Ethernet parameters of the CPU in HWCONFIG. 2. Check if CPU firmware version matches the HWCONFIG version
16#8236	The CPU parameter downloaded is incorrect: wrong NTP settings	1. Check the Ethernet parameters of the CPU in HWCONFIG. 2. Check if CPU firmware version matches the HWCONFIG version
16#8240	The CPU parameter downloaded is incorrect: Ether iLink	Redownload the parameters after modifying the configurations
16#8241	DNS setting error	Modify DNS settings and download again.
16#8522	Auto scanning is in progress	Auto scanning of module configuration is in progress. Please try again later.
16#853B	An I/O module is not configured.(wirte error)	Check if the module configuration in HWCONFIG is correct.
16#853C	An I/O module does not exist. (wirte error)	Check if the module configuration in HWCONFIG is correct.

Error Code	Description	Corrective action
16#854B	An I/O module is not configured. (read error)	Check if the module configuration in HWCONFIG is correct.
16#854C	An I/O module does not exist. (read error)	Check if the module configuration in HWCONFIG is correct.
16#8572	The checksum of the module configuration table is incorrect.	Please check the PLC firmware and the software version and contact the supplier.
16#8576	The checksum of the module parameter setting is incorrect.	Please check the PLC firmware and the software version and contact the supplier.
16#867A	The checksum of the module parameter mapping table is incorrect.	Please check the PLC firmware and the software version and contact the supplier.
16#85E1	An I/O interrupt number is incorrect.	Please check the PLC firmware version and contact the supplier.
16#85E2	An I/O interrupt service routine does not exist.	Please check if the corresponding interrupt program for the CPU is downloaded.
16#860F	System restoration error	The contents of the system backup file are incorrect, or the file does not exist in the path specified. If the file exists and the procedure of restoring the system can not be executed, please backing up the system again. If the error still occurs, please contact the manufacturer.
16#8611	No memory card exists, or the memory card format is incorrect.	The system cannot detect the memory card. Format the memory card and try again.
16#9A33	An error occurs when COM1 communicates with slave 19 by Modbus or PLC Link.	1. Check the communication setting between the connecting devices. 2. Check if the communication cable is damaged.
16#9A34	An error occurs when COM1 communicates with slave 20 by Modbus or PLC Link.	1. Check the communication setting between the connecting devices. 2. Check if the communication cable is damaged.
16#9A35	An error occurs when COM1 communicates with slave 21 by Modbus or PLC Link.	1. Check the communication setting between the connecting devices. 2. Check if the communication cable is damaged.
16#9A47	COM1 receives no response from slave 7 by Modbus or PLC Link. (SM1591)	1. Check the communication setting between the connecting devices. 2. Check if the communication cable is damaged.
16#9A61	PLC Link Mode setting error	Please make sure manual and automatic mode in PLC Link cannot be set to ON at the same time.
16#9A62	Current times of PLC LINK polling cycle	Make sure polling cycle value is set to be within 1~65535 when PLC Link is set to manual mode.
16#9A63	There is a handshaking timeout when the CPU module establishes a connection with the network module.	Check if the communication module functions properly.

Error Code	Description	Corrective action
16#9A64	There is no network module parameter in the CPU module.	Download HWCONFIG parameters again.
16#9B01	An error occurs when the Modbus connection of COM2 is initialized.	Reset the parameters of Modbus connection of COM2 in the HWCONFIG.
16#9B02	An error occurs when the Modbus connection of COM2 is initialized.	Reset COM2 MODBUS parameters in HWCONFIG.
16#9B03	An error occurs when the Modbus connection of COM2 is initialized.	Reset COM2 MODBUS parameters in HWCONFIG.
16#9B04	An error occurs when the Modbus connection of COM2 is initialized.	Reset COM2 MODBUS parameters in HWCONFIG.
16#9B05	An error occurs when the Modbus connection of COM2 is initialized.	Reset COM2 MODBUS parameters in HWCONFIG.
16#9B06	An error occurs when the Modbus connection of COM2 is initialized.	Reset COM2 MODBUS parameters in HWCONFIG.
16#9B07	An error occurs when the Modbus connection of COM2 is initialized.	Reset COM2 MODBUS parameters in HWCONFIG.
16#9B08	An error occurs when the Modbus connection of COM2 is initialized.	Reset COM2 MODBUS parameters in HWCONFIG.
16#9B09	An error occurs when the Modbus connection of COM2 is initialized.	Reset COM2 MODBUS parameters in HWCONFIG.
16#9B0A	An error occurs when the Modbus connection of COM2 is initialized.	Reset COM2 MODBUS parameters in HWCONFIG.
16#9B0B	An error occurs when the Modbus connection of COM2 is initialized.	Reset COM2 MODBUS parameters in HWCONFIG.
16#9B0C	An error occurs when the Modbus connection of COM2 is initialized.	Reset COM2 MODBUS parameters in HWCONFIG.
16#9B0D	An error occurs when the Modbus connection of COM2 is initialized.	Reset COM2 MODBUS parameters in HWCONFIG.
16#9B0E	An error occurs when the Modbus connection of COM2 is initialized.	Reset COM2 MODBUS parameters in HWCONFIG.
16#9B0F	An error occurs when the Modbus connection of COM2 is initialized.	Reset COM2 MODBUS parameters in HWCONFIG.
16#9B11	An error occurs when the Modbus connection of COM2 is initialized.	Reset COM2 MODBUS parameters in HWCONFIG.
16#9B12	An error occurs when the Modbus connection of COM2 is initialized.	Reset COM2 MODBUS parameters in HWCONFIG.
16#9B13	An error occurs when the Modbus connection of COM2 is initialized.	Reset COM2 MODBUS parameters in HWCONFIG.
16#9B14	An error occurs when the Modbus connection of COM2 is initialized.	Reset COM2 MODBUS parameters in HWCONFIG.

Error Code	Description	Corrective action
16#9B15	An error occurs when the Modbus connection of COM2 is initialized.	Reset COM2 MODBUS parameters in HWCONFIG.
16#9B16	An error occurs when the Modbus connection of COM2 is initialized.	Reset COM2 MODBUS parameters in HWCONFIG.
16#9B17	An error occurs when the Modbus connection of COM2 is initialized.	Reset COM2 MODBUS parameters in HWCONFIG.
16#9B18	An error occurs when the Modbus connection of COM2 is initialized.	Reset COM2 MODBUS parameters in HWCONFIG.
16#9B19	An error occurs when the Modbus connection of COM2 is initialized.	Reset COM2 MODBUS parameters in HWCONFIG.
16#9B1A	An error occurs when the Modbus connection of COM2 is initialized.	Reset COM2 MODBUS parameters in HWCONFIG.
16#9B1B	An error occurs when the Modbus connection of COM2 is initialized.	Reset COM2 MODBUS parameters in HWCONFIG.
16#9B1C	An error occurs when the Modbus connection of COM2 is initialized.	Reset COM2 MODBUS parameters in HWCONFIG.
16#9B1D	An error occurs when the Modbus connection of COM2 is initialized.	Reset COM2 MODBUS parameters in HWCONFIG.
16#9B1E	An error occurs when the Modbus connection of COM2 is initialized.	Reset COM2 MODBUS parameters in HWCONFIG.
16#9B1F	An error occurs when the Modbus connection of COM2 is initialized.	Reset COM2 MODBUS parameters in HWCONFIG.
16#9B20	An error occurs when the Modbus connection of COM2 is initialized.	Reset COM2 MODBUS parameters in HWCONFIG.
16#9B21	An error occurs when COM2 communicates with slave 1 by MODBUS.	<ol style="list-style-type: none"> <li>1. Check the communication setting between the connecting devices.</li> <li>2. Check if the communication cable is damaged.</li> </ol>
16#9B22	An error occurs when COM2 communicates with slave 2 by MODBUS.	<ol style="list-style-type: none"> <li>1. Check the communication setting between the connecting devices.</li> <li>2. Check if the communication cable is damaged.</li> </ol>
16#9B23	An error occurs when COM2 communicates with slave 3 by MODBUS.	<ol style="list-style-type: none"> <li>1. Check the communication setting between the connecting devices.</li> <li>2. Check if the communication cable is damaged.</li> </ol>
16#9B24	An error occurs when COM2 communicates with slave 4 by MODBUS.	<ol style="list-style-type: none"> <li>1. Check the communication setting between the connecting devices.</li> <li>2. Check if the communication cable is damaged.</li> </ol>
16#9B25	An error occurs when COM2 communicates with slave 5 by MODBUS.	<ol style="list-style-type: none"> <li>1. Check the communication setting between the connecting devices.</li> <li>2. Check if the communication cable is damaged.</li> </ol>



Error Code	Description	Corrective action
16#9B26	An error occurs when COM2 communicates with slave 6 by MODBUS.	1. Check the communication setting between the connecting devices. 2. Check if the communication cable is damaged.
16#9B27	An error occurs when COM2 communicates with slave 7 by MODBUS.	1. Check the communication setting between the connecting devices. 2. Check if the communication cable is damaged.
16#9B28	An error occurs when COM2 communicates with slave 8 by MODBUS.	1. Check the communication setting between the connecting devices. 2. Check if the communication cable is damaged.
16#9B29	An error occurs when COM2 communicates with slave 9 by MODBUS.	1. Check the communication setting between the connecting devices. 2. Check if the communication cable is damaged.
16#9B2A	An error occurs when COM2 communicates with slave 10 by MODBUS.	1. Check the communication setting between the connecting devices. 2. Check if the communication cable is damaged.
16#9B2B	An error occurs when COM2 communicates with slave 11 by MODBUS.	1. Check the communication setting between the connecting devices. 2. Check if the communication cable is damaged.
16#9B2C	An error occurs when COM2 communicates with slave 12 by MODBUS.	1. Check the communication setting between the connecting devices. 2. Check if the communication cable is damaged.
16#9B2D	An error occurs when COM2 communicates with slave 13 by MODBUS.	1. Check the communication setting between the connecting devices. 2. Check if the communication cable is damaged.
16#9B2E	An error occurs when COM2 communicates with slave 14 by MODBUS.	1. Check the communication setting between the connecting devices. 2. Check if the communication cable is damaged.
16#9B2F	An error occurs when COM2 communicates with slave 15 by MODBUS.	1. Check the communication setting between the connecting devices. 2. Check if the communication cable is damaged.
16#9B30	An error occurs when COM2 communicates with slave 16 by MODBUS.	1. Check the communication setting between the connecting devices. 2. Check if the communication cable is damaged.
16#9B31	An error occurs when COM2 communicates with slave 17 by MODBUS.	1. Check the communication setting between the connecting devices. 2. Check if the communication cable is damaged.
16#9B32	An error occurs when COM2 communicates with slave 18 by MODBUS.	1. Check the communication setting between the connecting devices. 2. Check if the communication cable is damaged.
16#9B33	An error occurs when COM2 communicates with slave 19 by MODBUS.	1. Check the communication setting between the connecting devices. 2. Check if the communication cable is damaged.

Error Code	Description	Corrective action
16#9B34	An error occurs when COM2 communicates with slave 20 by MODBUS.	1. Check the communication setting between the connecting devices. 2. Check if the communication cable is damaged.
16#9B35	An error occurs when COM2 communicates with slave 21 by MODBUS.	1. Check the communication setting between the connecting devices. 2. Check if the communication cable is damaged.
16#9B36	An error occurs when COM2 communicates with slave 22 by MODBUS.	1. Check the communication setting between the connecting devices. 2. Check if the communication cable is damaged.
16#9B37	An error occurs when COM2 communicates with slave 23 by MODBUS.	1. Check the communication setting between the connecting devices. 2. Check if the communication cable is damaged.
16#9B38	An error occurs when COM2 communicates with slave 24 by MODBUS.	1. Check the communication setting between the connecting devices. 2. Check if the communication cable is damaged.
16#9B39	An error occurs when COM2 communicates with slave 25 by MODBUS.	1. Check the communication setting between the connecting devices. 2. Check if the communication cable is damaged.
16#9B3A	An error occurs when COM2 communicates with slave 26 by MODBUS.	1. Check the communication setting between the connecting devices. 2. Check if the communication cable is damaged.
16#9B3B	An error occurs when COM2 communicates with slave 27 by MODBUS.	1. Check the communication setting between the connecting devices. 2. Check if the communication cable is damaged.
16#9B3C	An error occurs when COM2 communicates with slave 28 by MODBUS.	1. Check the communication setting between the connecting devices. 2. Check if the communication cable is damaged.
16#9B3D	An error occurs when COM2 communicates with slave 29 by MODBUS.	1. Check the communication setting between the connecting devices. 2. Check if the communication cable is damaged.
16#9B3E	An error occurs when COM2 communicates with slave 30 by MODBUS.	1. Check the communication setting between the connecting devices. 2. Check if the communication cable is damaged.
16#9B3F	An error occurs when COM2 communicates with slave 31 by MODBUS.	1. Check the communication setting between the connecting devices. 2. Check if the communication cable is damaged.
16#9B40	An error occurs when COM2 communicates with slave 32 by MODBUS.	1. Check the communication setting between the connecting devices. 2. Check if the communication cable is damaged.
16#9B41	COM2 receives no response from slave 1 by MODBUS.	1. Check the communication setting between the connecting devices. 2. Check if the communication cable is damaged.

Error Code	Description	Corrective action
16#9B42	COM2 receives no response from slave 2 by MODBUS.	<ol style="list-style-type: none"> <li>1. Check the communication setting between the connecting devices.</li> <li>2. Check if the communication cable is damaged.</li> </ol>
16#9B43	COM2 receives no response from slave 3 by MODBUS.	<ol style="list-style-type: none"> <li>1. Check the communication setting between the connecting devices.</li> <li>2. Check if the communication cable is damaged.</li> </ol>
16#9B44	COM2 receives no response from slave 4 by MODBUS.	<ol style="list-style-type: none"> <li>1. Check the communication setting between the connecting devices.</li> <li>2. Check if the communication cable is damaged.</li> </ol>
16#9B45	COM2 receives no response from slave 5 by MODBUS.	<ol style="list-style-type: none"> <li>1. Check the communication setting between the connecting devices.</li> <li>2. Check if the communication cable is damaged.</li> </ol>
16#9B46	COM2 receives no response from slave 6 by MODBUS.	<ol style="list-style-type: none"> <li>1. Check the communication setting between the connecting devices.</li> <li>2. Check if the communication cable is damaged.</li> </ol>
16#9B47	COM2 receives no response from slave 7 by MODBUS.	<ol style="list-style-type: none"> <li>1. Check the communication setting between the connecting devices.</li> <li>2. Check if the communication cable is damaged.</li> </ol>
16#9B48	COM2 receives no response from slave 8 by MODBUS.	<ol style="list-style-type: none"> <li>1. Check the communication setting between the connecting devices.</li> <li>2. Check if the communication cable is damaged.</li> </ol>
16#9B49	COM2 receives no response from slave 9 by MODBUS.	<ol style="list-style-type: none"> <li>1. Check the communication setting between the connecting devices.</li> <li>2. Check if the communication cable is damaged.</li> </ol>
16#9B4A	COM2 receives no response from slave 10 by MODBUS.	<ol style="list-style-type: none"> <li>1. Check the communication setting between the connecting devices.</li> <li>2. Check if the communication cable is damaged.</li> </ol>
16#9B4B	COM2 receives no response from slave 11 by MODBUS.	<ol style="list-style-type: none"> <li>1. Check the communication setting between the connecting devices.</li> <li>2. Check if the communication cable is damaged.</li> </ol>
16#9B4C	COM2 receives no response from slave 12 by MODBUS.	<ol style="list-style-type: none"> <li>1. Check the communication setting between the connecting devices.</li> <li>2. Check if the communication cable is damaged.</li> </ol>
16#9B4D	COM2 receives no response from slave 13 by MODBUS.	<ol style="list-style-type: none"> <li>1. Check the communication setting between the connecting devices.</li> <li>2. Check if the communication cable is damaged.</li> </ol>
16#9B4E	COM2 receives no response from slave 14 by MODBUS.	<ol style="list-style-type: none"> <li>1. Check the communication setting between the connecting devices.</li> <li>2. Check if the communication cable is damaged.</li> </ol>
16#9B4F	COM2 receives no response from slave 15 by MODBUS.	<ol style="list-style-type: none"> <li>1. Check the communication setting between the connecting devices.</li> <li>2. Check if the communication cable is damaged.</li> </ol>

Error Code	Description	Corrective action
16#9B50	COM2 receives no response from slave 16 by MODBUS.	1. Check the communication setting between the connecting devices. 2. Check if the communication cable is damaged.
16#9B51	COM2 receives no response from slave 17 by MODBUS.	1. Check the communication setting between the connecting devices. 2. Check if the communication cable is damaged.
16#9B52	COM2 receives no response from slave 18 by MODBUS.	1. Check the communication setting between the connecting devices. 2. Check if the communication cable is damaged.
16#9B53	COM2 receives no response from slave 19 by MODBUS.	1. Check the communication setting between the connecting devices. 2. Check if the communication cable is damaged.
16#9B54	COM2 receives no response from slave 20 by MODBUS.	1. Check the communication setting between the connecting devices. 2. Check if the communication cable is damaged.
16#9B55	COM2 receives no response from slave 21 by MODBUS.	1. Check the communication setting between the connecting devices. 2. Check if the communication cable is damaged.
16#9B56	COM2 receives no response from slave 22 by MODBUS.	1. Check the communication setting between the connecting devices. 2. Check if the communication cable is damaged.
16#9B57	COM2 receives no response from slave 23 by MODBUS.	1. Check the communication setting between the connecting devices. 2. Check if the communication cable is damaged.
16#9B58	COM2 receives no response from slave 24 by MODBUS.	1. Check the communication setting between the connecting devices. 2. Check if the communication cable is damaged.
16#9B59	COM2 receives no response from slave 25 by MODBUS.	1. Check the communication setting between the connecting devices. 2. Check if the communication cable is damaged.
16#9B5A	COM2 receives no response from slave 26 by MODBUS.	1. Check the communication setting between the connecting devices. 2. Check if the communication cable is damaged.
16#9B5B	COM2 receives no response from slave 27 by MODBUS.	1. Check the communication setting between the connecting devices. 2. Check if the communication cable is damaged.
16#9B5C	COM2 receives no response from slave 28 by MODBUS.	1. Check the communication setting between the connecting devices. 2. Check if the communication cable is damaged.
16#9B5D	COM2 receives no response from slave 29 by MODBUS.	1. Check the communication setting between the connecting devices. 2. Check if the communication cable is damaged.

Error Code	Description	Corrective action
16#9B5E	COM2 receives no response from slave 30 by MODBUS.	1. Check the communication setting between the connecting devices. 2. Check if the communication cable is damaged.
16#9B5F	COM2 receives no response from slave 31 by MODBUS.	1. Check the communication setting between the connecting devices. 2. Check if the communication cable is damaged.
16#9B60	COM2 receives no response from slave 32 by MODBUS.	1. Check the communication setting between the connecting devices. 2. Check if the communication cable is damaged.

## 9.4 Troubleshooting for I/O Modules

### 9.4.1. Analog I/O Modules and Temperature Measurement Modules

Error code	Description	Corrective action
16#A000	The signal received by channel 0 exceeds the range of inputs which can be received by the hardware. (The ERROR LED indicator blinks.)	Check the module parameter in HWCONFIG. Check whether the signal received by channel 0 exceeds the range of inputs which can be received by the hardware.
16#A001	The signal received by channel 1 exceeds the range of inputs which can be received by the hardware. (The ERROR LED indicator blinks.)	Check the module parameter in HWCONFIG. Check whether the signal received by channel 1 exceeds the range of inputs which can be received by the hardware.
16#A002	The signal received by channel 2 exceeds the range of inputs which can be received by the hardware. (The ERROR LED indicator blinks.)	Check the module parameter in HWCONFIG. Check whether the signal received by channel 2 exceeds the range of inputs which can be received by the hardware.
16#A003	The signal received by channel 3 exceeds the range of inputs which can be received by the hardware. (The ERROR LED indicator blinks.)	Check the module parameter in HWCONFIG. Check whether the signal received by channel 3 exceeds the range of inputs which can be received by the hardware.
16#A004	The signal received by channel 4 exceeds the range of inputs which can be received by the hardware. (The ERROR LED indicator blinks.)	Check the module parameter in HWCONFIG. Check whether the signal received by channel 4 exceeds the range of inputs which can be received by the hardware.
16#A005	The signal received by channel 5 exceeds the range of inputs which can be received by the hardware. (The ERROR LED indicator blinks.)	Check the module parameter in HWCONFIG. Check whether the signal received by channel 5 exceeds the range of inputs which can be received by the hardware.
16#A006	The signal received by channel 6 exceeds the range of inputs which can be received by the hardware. (The ERROR LED indicator blinks.)	Check the module parameter in HWCONFIG. Check whether the signal received by channel 6 exceeds the range of inputs which can be received by the hardware.

Error code	Description	Corrective action
16#A007	The signal received by channel 7 exceeds the range of inputs which can be received by the hardware. (The ERROR LED indicator blinks.)	Check the module parameter in HWCONFIG. Check whether the signal received by channel 7 exceeds the range of inputs which can be received by the hardware.
16#A400	The signal received by channel 0 exceeds the range of inputs which can be received by the hardware. (The ERROR LED indicator is ON.)	Check the module parameter in HWCONFIG. Check whether the signal received by channel 0 exceeds the range of inputs which can be received by the hardware.
16#A401	The signal received by channel 1 exceeds the range of inputs which can be received by the hardware. (The ERROR LED indicator is ON.)	Check the module parameter in HWCONFIG. Check whether the signal received by channel 1 exceeds the range of inputs which can be received by the hardware.
16#A402	The signal received by channel 2 exceeds the range of inputs which can be received by the hardware. (The ERROR LED indicator is ON.)	Check the module parameter in HWCONFIG. Check whether the signal received by channel 2 exceeds the range of inputs which can be received by the hardware.
16#A403	The signal received by channel 3 exceeds the range of inputs which can be received by the hardware. (The ERROR LED indicator is ON.)	Check the module parameter in HWCONFIG. Check whether the signal received by channel 3 exceeds the range of inputs which can be received by the hardware.
16#A404	The signal received by channel 4 exceeds the range of inputs which can be received by the hardware. (The ERROR LED indicator is ON.)	Check the module parameter in HWCONFIG. Check whether the signal received by channel 4 exceeds the range of inputs which can be received by the hardware.
16#A405	The signal received by channel 5 exceeds the range of inputs which can be received by the hardware. (The ERROR LED indicator is ON.)	Check the module parameter in HWCONFIG. Check whether the signal received by channel 5 exceeds the range of inputs which can be received by the hardware.
16#A406	The signal received by channel 6 exceeds the range of inputs which can be received by the hardware. (The ERROR LED indicator is ON.)	Check the module parameter in HWCONFIG. Check whether the signal received by channel 6 exceeds the range of inputs which can be received by the hardware.
16#A407	The signal received by channel 7 exceeds the range of inputs which can be received by the hardware. (The ERROR LED indicator is ON.)	Check the module parameter in HWCONFIG. Check whether the signal received by channel 7 exceeds the range of inputs which can be received by the hardware.
16#A600	Hardware failure	1. Check whether the backplane is normal. 2. Check whether the module operate normally.
16#A601	The external voltage is abnormal.	Check whether the external 24 V power supply to the module is normal.
16#A602	Internal error The CJC is abnormal.	Please contact the manufacturer.

Error code	Description	Corrective action
16#A603	Internal error The factory correction is abnormal.	Please contact the manufacturer.
16#A800	The signal received by channel 0 exceeds the range of inputs which can be received by the hardware. (The ERROR LED indicator is OFF.)	Check the module parameter in HWCONFIG. Check whether the signal received by channel 0 exceeds the range of inputs which can be received by the hardware.
16#A801	The signal received by channel 1 exceeds the range of inputs which can be received by the hardware. (The ERROR LED indicator is OFF.)	Check the module parameter in HWCONFIG. Check whether the signal received by channel 1 exceeds the range of inputs which can be received by the hardware.
16#A802	The signal received by channel 2 exceeds the range of inputs which can be received by the hardware. (The ERROR LED indicator is OFF.)	Check the module parameter in HWCONFIG. Check whether the signal received by channel 2 exceeds the range of inputs which can be received by the hardware.
16#A803	The signal received by channel 3 exceeds the range of inputs which can be received by the hardware. (The ERROR LED indicator is OFF.)	Check the module parameter in HWCONFIG. Check whether the signal received by channel 3 exceeds the range of inputs which can be received by the hardware.
16#A804	The signal received by channel 4 exceeds the range of inputs which can be received by the hardware. (The ERROR LED indicator is OFF.)	Check the module parameter in HWCONFIG. Check whether the signal received by channel 4 exceeds the range of inputs which can be received by the hardware.
16#A805	The signal received by channel 5 exceeds the range of inputs which can be received by the hardware. (The ERROR LED indicator is OFF.)	Check the module parameter in HWCONFIG. Check whether The signal received by channel 5 exceeds the range of inputs which can be received by the hardware.
16#A806	The signal received by channel 6 exceeds the range of inputs which can be received by the hardware. (The ERROR LED indicator is OFF.)	Check the module parameter in HWCONFIG. Check whether the signal received by channel 6 exceeds the range of inputs which can be received by the hardware.
16#A807	The signal received by channel 7 exceeds the range of inputs which can be received by the hardware. (The ERROR LED indicator is OFF.)	Check the module parameter in HWCONFIG. Check whether the signal received by channel 7 exceeds the range of inputs which can be received by the hardware.

#### 9.4.2. AH02HC-5A/AH04HC-5A

Error code	Description	Corrective action
16#A001	The linear accumulation in channel 1 exceeds the range.	To clear the linear accumulation, users need to set bit 1 in CR0 to ON by means of FROM/TO.

Error code	Description	Corrective action
16#A002	The scale set for channel 1 exceeds the range.	Check the module parameter in HWCONFIG. The scale set for channel 1 should be in the range of 0 to 32767.
16#A003	The number of cycles set for channel 1 exceeds the range.	Check the module parameter in HWCONFIG. The number of cycles set for channel 1 should be in the range of 2 to 60.
16#A004	The comparison value set for channel 1 exceeds the range.	Check the module parameter in HWCONFIG. The comparison value set for channel 1 should be in the range of -999999999 to 999999999.
16#A005	A limit value set for channel 1 is incorrect.	Check the module parameter in HWCONFIG. A limit value of set for channel 1 should be in the range of -200000 to 200000.
16#A006	The interrupt number set for channel 1 exceeds the range.	Check the module parameter in HWCONFIG. The interrupt number set for channel 1 should be in the range of 0 to 31.
16#A011	The linear accumulation in channel 1 exceeds the range.	To clear the linear accumulation, users need to set bit 1 in CR28 to ON by means of FROM/TO.
16#A012	The scale set for channel 2 exceeds the range.	Check the module parameter in HWCONFIG. The scale set for channel 2 should be in the range of 0 to 32767.
16#A013	The number of cycles set for channel 2 exceeds the range.	Check the module parameter in HWCONFIG. The number of cycles set for channel 2 should be in the range of 2 to 60.
16#A014	The comparison value set for channel 2 exceeds the range.	Check the module parameter in HWCONFIG. The comparison value set for channel 2 should be in the range of -999999999 to 999999999.
16#A015	A limit value set for channel 2 is incorrect.	Check the module parameter in HWCONFIG. A limit value of set for channel 2 should be in the range of -200000 to 200000.
16#A016	The interrupt number set for channel 2 exceeds the range.	Check the module parameter in HWCONFIG. The interrupt number set for channel 2 should be in the range of 0 to 31.
16#A021	The linear accumulation in channel 3 exceeds the range.	To clear the linear accumulation, users need to set bit 1 in CR56 to ON by means of FROM/TO.
16#A022	The scale set for channel 3 exceeds the range.	Check the module parameter in HWCONFIG. The scale set for channel 3 should be in the range of 0 to 32767.
16#A023	The number of cycles set for channel 3 exceeds the range.	Check the module parameter in HWCONFIG. The number of cycles set for channel 3 should be in the range of 2 to 60.



Error code	Description	Corrective action
16#A024	The comparison value set for channel 3 exceeds the range.	Check the module parameter in HWCONFIG. The comparison value set for channel 3 should be in the range of -999999999 to 999999999.
16#A025	A limit value set for channel 3 is incorrect.	Check the module parameter in HWCONFIG. A limit value of set for channel 3 should be in the range of -200000 to 200000.
16#A026	The interrupt number set for channel 3 exceeds the range.	Check the module parameter in HWCONFIG. The interrupt number set for channel 3 should be in the range of 0 to 31.
16#A031	The linear accumulation in channel 4 exceeds the range.	To clear the linear accumulation, users need to set bit 1 in CR84 to ON by means of FROM/TO.
16#A032	The scale set for channel 4 exceeds the range.	Check the module parameter in HWCONFIG. The scale set for channel 4 should be in the range of 0 to 32767.
16#A033	The number of cycles set for channel 4 exceeds the range.	Check the module parameter in HWCONFIG. The number of cycles set for channel 4 should be in the range of 2 to 60.
16#A034	The comparison value set for channel 4 exceeds the range.	Check the module parameter in HWCONFIG. The comparison value set for channel 4 should be in the range of -999999999 to 999999999.
16#A035	A limit value set for channel 4 is incorrect.	Check the module parameter in HWCONFIG. A limit value of set for channel 4 should be in the range of -200000 to 200000.
16#A036	The interrupt number set for channel 4 exceeds the range.	Check the module parameter in HWCONFIG. The interrupt number set for channel 4 should be in the range of 0 to 31.

### 9.4.3. AH05PM-5A/AH10PM-5A/AH15PM-5A

The programs and the setting which are mentioned in the table below are edited in PMSOFT version 2.02 or above.

Error code	Description	Corrective action
16#A002	The subroutine has no data.	A program should be written in the subroutine.
16#A003	CJ, CJK, and JMP have no matching pointers.	Write the pointers which match CJ, CJK, and JMP respectively.
16#A004	There is a subroutine pointer in the main program.	The subroutine pointer can not be in the main program.
16#A005	Lack of the subroutine	The nonexistent subroutine can not be called.
16#A006	The pointer is used repeatedly in the same program.	The pointer can not be used repeatedly in the same program.

Error code	Description	Corrective action
16#A007	The subroutine pointer is used repeatedly.	The subroutine pointer can not be used repeatedly.
16#A008	The pointer used in JMP is used repeatedly in different subroutines.	The pointer used in JMP can not be used repeatedly in different subroutines.
16#A009	The pointer used in JMP is the same as the pointer used in CALL.	The pointer used in JMP can not be the same as the pointer used in CALL.
16#A00A	The pointer used in JMP is the same as a subroutine pointer.	The pointer used in JMP can not be the same as a subroutine pointer.
16#A00B	Target position (I) of the single speed is incorrect.	The target position (I) of the single speed should be set correctly.
16#A00C	Target position (II) of the single-axis motion is incorrect.	Check whether target position (II) of the single-axis motion and target position (I) of the single-axis motion are in opposite directions.
16#A00D	The setting of speed (I) of the single-axis motion is incorrect.	Set the speed of the single-axis motion.
16#A00E	The setting of speed (II) of the single-axis motion is incorrect.	The setting value can not be zero.
16#A00F	The setting of the speed ( $V_{RT}$ ) of returning to zero is incorrect.	Set the speed of returning to zero properly. (The setting value can not be zero.)
16#A010	The setting of the deceleration ( $V_{CR}$ ) of returning to zero is incorrect.	Set the speed of returning to zero. The deceleration should be less than the speed of returning to zero. (The setting value can not be zero.)
16#A011	The setting of the JOG speed is incorrect.	The setting value can not be zero.
16#A012	The positive pulses generated by the single-axis clockwise motion are inhibited.	The error occurs because the limit sensor is triggered. Check the status of the limit sensor, and check whether the motor operates normally.
16#A013	The negative pulses generated by the single-axis counterclockwise motion are inhibited.	The error occurs because the limit sensor is triggered. Check the status of the limit sensor, and check whether the motor operates normally.
16#A014	The limit switch is reached.	The error occurs because the limit sensor is triggered. Check the status of the limit sensor, and check whether the motor operates normally.
16#A015	The device which is used exceeds the device range.	Use the device which does not exceed the device range.
16#A017	An error occurs when the device is modified by a 16-bit index register/32-bit index register.	Use the 16-bit index register/32-bit index register which does not exceed the device range.

Error code	Description	Corrective action
16#A018	The conversion into the floating-point number is incorrect.	Modify the operation to prevent the abnormal number from occurring.
16#A019	The conversion into the binary-coded decimal number is incorrect.	Modify the operation to prevent the abnormal number from occurring.
16#A01A	Incorrect division operation (The divisor is 0.)	Modify the operation to prevent the divisor from being zero.
16#A01B	General program error	Modify the program to make the syntax correct.
16#A01C	LD/LDI has been used more than nine times.	Modify the program to prevent LD/LDI from being used more than nine times.
16#A01D	There is more than one level of nested program structure supported by RPT/RPE.	Modify the program to prevent more than one level of nested program structure supported by RPT/RPE from being used.
16#A01E	SRET is used between RPT and RPE.	Modify the program to prevent SRET from being used between RPT and RPE.
16#A01F	There is no M102 in the main program, or there is no M2 in the motion program.	Modify the program so that there is M102 in the main program, or modify the program so that there is M2 in the motion program.
16#A020	The wrong instruction is used, or the device used exceeds the range.	Check and modify the program to prevent the wrong instruction from being used, or check whether the device used exceeds the device range.

### 9.4.4. AH20MC-5A

The programs and the setting which are mentioned in the table below are edited in PMSoft version 2.02 or above.

Error code	Description	Corrective action
16#A002	The subroutine has no data.	A program should be written in the subroutine.
16#A003	CJ, CJN, and JMP have no matching pointers.	Write the pointers which match CJ, CJN, and JMP respectively.
16#A004	There is a subroutine pointer in the main program.	The subroutine pointer can not be in the main program.
16#A005	Lack of the subroutine	The nonexistent subroutine can not be called.
16#A006	The pointer is used repeatedly in the same program.	The pointer can not be used repeatedly in the same program.
16#A007	The subroutine pointer is used repeatedly.	The subroutine pointer can not be used repeatedly.
16#A008	The pointer used in JMP is used repeatedly in different subroutines.	The pointer used in JMP can not be used repeatedly in different subroutines.
16#A009	The pointer used in JMP is the same as the pointer used in CALL.	The pointer used in JMP can not be the same as the pointer used in CALL.
16#A00A	The pointer used in JMP is the same as a subroutine pointer.	The pointer used in JMP can not be the same as a subroutine pointer.
16#A00B	Target position (I) of the single speed is incorrect.	The target position (I) of the single speed should be set correctly.
16#A00C	Target position (II) of the single-axis motion is incorrect.	Check whether target position (II) of the single-axis motion and target position (I) of the single-axis motion are in opposite directions.
16#A00D	The setting of speed (I) of the single-axis motion is incorrect.	Set the speed of the single-axis motion.
16#A00E	The setting of speed (II) of the single-axis motion is incorrect.	The setting value can not be zero.
16#A00F	The setting of the speed ( $V_{RT}$ ) of returning to zero is incorrect.	Set the speed of returning to zero properly. (The setting value can not be zero.)
16#A010	The setting of the deceleration ( $V_{CR}$ ) of returning to zero is incorrect.	Set the speed of returning to zero. The deceleration should be less than the speed of returning to zero. (The setting value can not be zero.)
16#A011	The setting of the JOG speed is incorrect.	The setting value can not be zero.
16#A012	The positive pulses generated by the single-axis clockwise motion are inhibited.	The error occurs because the limit sensor is triggered. Check the status of the limit sensor, and check whether the motor operates normally.

Error code	Description	Corrective action
16#A013	The negative pulses generated by the single-axis counterclockwise motion are inhibited.	The error occurs because the limit sensor is triggered. Check the status of the limit sensor, and check whether the motor operates normally.
16#A014	The limit switch is reached.	The error occurs because the limit sensor is triggered. Check the status of the limit sensor, and check whether the motor operates normally.
16#A015	The device which is used exceeds the device range.	Use the device which does not exceed the device range.
16#A017	An error occurs when the device is modified by a 16-bit index register/32-bit index register.	Use the 16-bit index register/32-bit index register which does not exceed the device range.
16#A018	The conversion into the floating-point number is incorrect.	Modify the operation to prevent the abnormal number from occurring.
16#A019	The conversion into the binary-coded decimal number is incorrect.	Modify the operation to prevent the abnormal number from occurring.
16#A01A	Incorrect division operation (The divisor is 0.)	Modify the operation to prevent the divisor from being zero.
16#A01B	General program error	Modify the program to make the syntax correct.
16#A01C	LD/LDI has been used more than nine times.	Modify the program to prevent LD/LDI from being used more than nine times.
16#A01D	There is more than one level of nested program structure supported by RPT/RPE.	Modify the program to prevent more than one level of nested program structure supported by RPT/RPE from being used.
16#A01E	SRET is used between RPT and RPE.	Modify the program to prevent SRET from being used between RPT and RPE.
16#A01F	There is no M102 in the main program, or there is no M2 in the motion program.	Modify the program so that there is M102 in the main program, or modify the program so that there is M2 in the motion program.
16#A020	The wrong instruction is used, or the device used exceeds the range.	Check and modify the program to prevent the wrong instruction from being used, or check whether the device used exceeds the device range.

#### 9.4.5. AH10EN-5A/AH15EN-5A

Error code	Description	Remedy
16#A001	The IP address of host 1 conflicts with another system on the network.	1. Contact the network administrator, and check whether the IP address is correct. 2. Check the module parameter in HWCONFIG.
16#A002	The IP address of host 2 conflicts with another system on the network.	1. Contact the network administrator, and check whether the IP address is correct. 2. Check the module parameter in HWCONFIG.
16#A003	DHCP for host 1 fails.	Please contact the network administrator

Error code	Description	Remedy
16#A004	DHCP for host 2 fails.	Please contact the network administrator
16#A401	Hardware error	Please restore the hardware to the factory setting. If the error still occurs, please contact the factory.
16#A402	The initialization of the system fails.	Please restore the system to the factory setting. If the error still occurs, please contact the factory.

#### 9.4.6. AH10SCM-5A/AH15SCM-5A

Error code	Description	Corrective action
16#A002	The setting of the UD Link is incorrect, or the communication fails.	Check the setting in SCMSOFT, and download the setting again.
16#A401	Hardware error	Please contact the manufacturer.
16#A804	The communication through the communication port is incorrect.	<ol style="list-style-type: none"> <li>1. Check whether the communication cable is connected well.</li> <li>2. Check the parameter in HWCONFIG, and the parameter. Download the parameter again.</li> </ol>
16#A808	MODBUS communication error	<ol style="list-style-type: none"> <li>1. Check whether the communication cable is connected well.</li> <li>2. Check the parameter in HWCONFIG, and the parameter. Download the parameter again.</li> </ol>

#### 9.4.7. AH10DNET-5A

Error code	Description	Remedy
16#A0F0	The node ID of AH10DNET-5A is the same as other node ID on the network, or exceeds the range.	Make sure that the node ID of AH10DNET-5A is the only one on the network. If the node ID of AH10DNET-5A is not the only one on the network, please change the node ID, and supply power to AH10DNET-5 again.
16#A0F1	No slave is put on the scan list of AH10DNET-5A.	Put slaves on the scan list, and then download the scan list to AH10DNET-5A.
16#A0F2	The working voltage of AH10DNET-5A is low.	Check whether the working voltage of AH10DNET-5A and that of an AH500 series CPU module are normal.
16#A0F3	AH10DNET-5A enters the test mode.	Switch IN 1 on the module OFF, and supply power to AH10DNET-5A again.
16#A0F4	The bus of AH10DNET-5A becomes OFF.	<ol style="list-style-type: none"> <li>1. Check whether the communication cable is normal, and whether the shielded cable is grounded.</li> <li>2. Check whether the serial transmission speeds of other devices on the network are the same.</li> <li>3. Check whether the both ends of the cable are connected to 121 <math>\Omega</math> terminal resistors.</li> <li>4. Supply power to AH10DNET-5A again.</li> </ol>
16#A0F5	AH10DNET-5A detects that there is no power supply to the DeviceNet network.	Check whether the communication cable is normal, and whether the network power supply is normal.

Error code	Description	Remedy
16#A0F6	Something is wrong with the internal memory of AH10DNET-5A.	Supply power to AH10DNET-5A again. If the error still occurs, please contact the factory.
16#A0F7	Something is wrong with the data exchange unit of AH10DNET-5A.	Supply power to AH10DNET-5A again. If the error still occurs, please contact the factory.
16#A0F8	The product ID of AH10DNET-5A is incorrect.	Supply power to AH10DNET-5A again. If the error still occurs, please contact the factory.
16#A0F9	An error occurs when the data is read from AH10DNET-5A, or when the data is written into AH10DNET-5A.	Supply power to AH10DNET-5A again. If the error still occurs, please contact the factory.
16#A0FA	The node ID of AH10DNET-5A is the same as that of the slave set on the scan list.	Method 1: Set the node ID of AH10DNET-5A again. The new node ID can not be the same as the node ID of the slave set on the scan list. Supply power to AH10DNET-5A again. Method 2: Put no slave on the scan list, and download the blank scan list to AH10DNET-5A through the simulated online mode in the software. Supply power to AH10DNET-5A again.
16#A0FB	The data exchange between AH10DNET and AH CPU failed.	Supply power to the AH10DNET and AH CPU and try to exchange data again. If the issue continues, contact the factory.
16#A0FC	Errors occur in the slaves, on the module of an AHRTU-DNET backplane, or on the AHRTU-DNET backplane connection.	Check whether the node number has changed. Check if the network connection cable is secured and working fine. Check if the network transmission cable does not exceed the maximum communication distance (refer to AH500 module manual section 10.3.3 for more information). Do not exceed the maximum communication distance to ensure a stable network. Check if the module on the backplane is working fine. Check if the AHRTU-DNET backplane connection is working fine.

#### 9.4.8. AH10PFBM-5A

Error code	Description	Remedy
16#A001	The master is not set.	Download appropriate setting.
16#A003	The master station enters the test mode.	Just repower it.
16#A005	A timeout occurs when chips inside the master station communicate.	Download the appropriate configuration again. If the error still occurs, please contact the factory.
16#A00B	A timeout occurs when AH10PFBM-5A exchanges data exchange with a PLC.	Repower AH10PFBM-5A . If the error still occurs, please contact the factory.
16#A402	The PLC does not assign the I/O mapping area to the master.	Assign the appropriate I/O mapping area to the master via ISPSOft.
16#A404	Master initializing error	Contact the factory if the error still exists after repowering AH10PFBM-5A.

Error code	Description	Remedy
16#A406	Internal storage unit error	Contact the factory if the error still exists after repowering AH10PFBS-5A.
16#A407	Data exchange unit error	Contact the factory if the error still exists after repowering AH10PFBS-5A.
16#A408	Master serial number detection error	Contact the factory if the error still exists after repowering AH10PFBS-5A.
16#A4E2	The master detects that the slave is offline.	<ol style="list-style-type: none"> <li>1. Check whether the PROFIBUS-DP bus connection is normal.</li> <li>2. Check whether both of the ends of the network have terminal resistors.</li> </ol>
16#A4E6	The master detects that an error occurs in the module connected to AHRTU-PFBS-5A.	Check the modules connected to AHRTU-PFBS-5A.

#### 9.4.9. AH10PFBS-5A

Error code	Description	Remedy
16#A4F0	The node address of AH10PFBS-5A exceeds the valid range.	The node address of AH10PFBS-5A must be in the range of 1 to 125.
16#A4F1	Internal hardware error	If the error still exists after repowering AH10PFBS-5A, replace it with a new one.
16#A4F2	Parameter error	Check whether the GSD file AH10PFBS-5A is using is correct.
16#A4F3	Configuration error	Check whether the GSD file AH10PFBS-5A is using is correct.
16#A4F4	GPIO detection error	If the error still exists after repowering AH10PFBS-5A, replace it with a new one.
16#A4F5	AH10PFBS-5A enters the mode of factory test.	Repower AH10PFBS-5A after setting its node address between 1~125.
16#A4F6	<ol style="list-style-type: none"> <li>1. AH10PFBS-5A has not been connected to the PROFIBUS-DP network.</li> <li>2. PROFIBUS-DP master has not configured AH10PFBS-5A slave or the configured node address of AH10PFBS-5A is inconsistent with that of the actually connected one.</li> </ol>	<ol style="list-style-type: none"> <li>1. Check whether the communication cable between AH10PFBS-5A and PROFIBUS-DP master is in normal status.</li> <li>2. Ensure that AH10PFBS-5A slave has been configured to PROFIBUS-DP master and the configured node address of AH10PFBS-5A is consistent with that of the actually connected one.</li> <li>3. Check whether the PROFIBUS-DP master works normally.</li> </ol>

#### 9.4.10. AH10COPM-5A

Error code	Description	Corrective action
16#A0B0	AH10COPM-5A does not send a heartbeat message after a set period of time.	Check whether the bus cable on the CANopen network created is connected correctly.
16#A0B1	The length of a PDO that a slave station sends is not the same as the length of the PDO set in the node list.	Set the length of the PDO in the slave station again, and then download the setting to AH10COPM-5A.



Error code	Description	Corrective action
16#A0B2	The master station selected does not send a node guarding message after a set period of time.	Check whether the bus cable on the CANopen network created is connected correctly.
16#A0E0	AH10COPM-5A receives an emergency message from a slave station.	Use the function block CANopen_EMCY to read relevant information.
16#A0E1	The length of a PDO that a slave station sends is not the same as the length of the PDO set in the node list.	Set the length of the PDO in the slave station again, and then download the setting to AH10COPM-5A.
16#A0E2	AH10COPM-5A does not receive a PDO from a slave station.	Make sure that the PDOs in the slave station are set correctly.
16#A0E3	An automatic SDO is not downloaded successfully.	Make sure that the automatic SDO is set correctly.
16#A0E4	A PDO parameter is not set successfully.	Make sure that the setting of the PDO parameter is legal.
16#A0E5	A key parameter is set incorrectly.	Make sure that the slave stations connected are the same as the slave stations set.
16#A0E6	The actual network configuration is not the same as the network configuration set.	Make sure that the power supplied to the slave stations connected is normal and the network created is connected correctly.
16#A0E7	The control of the errors in a slave station is not sent after a set period of time.	
16#A0E8	The master station address is the same as a slave station address.	Set the master station address or the slave station address again, and make sure the new station address is not the same as a slave station address.
16#A0F1	No slave station is added to the node list in CANopen builder.	Add slave stations to the node list, and download the configuration to AH10COPM-5A.
16#A0F3	An error occurs in AH10COPM-5A.	Download parameters again. If the error still occurs, please replace AH10COPM-5A.
16#A0F4	The bus used is off.	Please check whether the bus cable on the CANopen network created is connected correctly, make sure that the serial transmission speeds of all the nodes on the network are the same, and power AH10COPM-5A again.
16#A0F5	The node address of AH10COPM-5A is set incorrectly.	The node address of AH10COPM-5A must be in the range of 1 to 127.
16#A0F6	Internal error: An error occurs in the manufacturing process in the factory.	Power AH10COPM-5A again. If the error still occurs, please replace AH10COPM-5A.
16#A0F7	Internal error: GPIO error	

Error code	Description	Corrective action
16#A0F8	Hardware error	
16#A0F9	Low voltage	Make sure that the power supplied to AH10COPM-5A is normal.
16#A0FA	An error occurs in the firmware of AH10COPM-5A.	Power AH10COPM-5A again.
16#A0FB	The transmission registers in AH10COPM-5A are full.	Please make sure that the bus cable on the CANopen network created is connected correctly, and power AH10COPM-5A again.
16#A0FC	The reception registers in AH10COPM-5A are full.	Please make sure that the bus cable on the CANopen network created is connected correctly, and power AH10COPM-5A again.

## 9.5 Troubleshooting for Limitation Errors

### 9.5.1. Software limit errors

The controller system checks the software limits before or during the motion by the error code 0x3911. When the operation exceeds the software limits, the error code will be indicated and the axis will enter "ErrorStop". Servo drive will not report this error since the error handling in this case is controlled by the controller. Note: for details on the software limit setups, refer to ISPSOFT manual. Do not set the values too close to the value of the software upper limit.

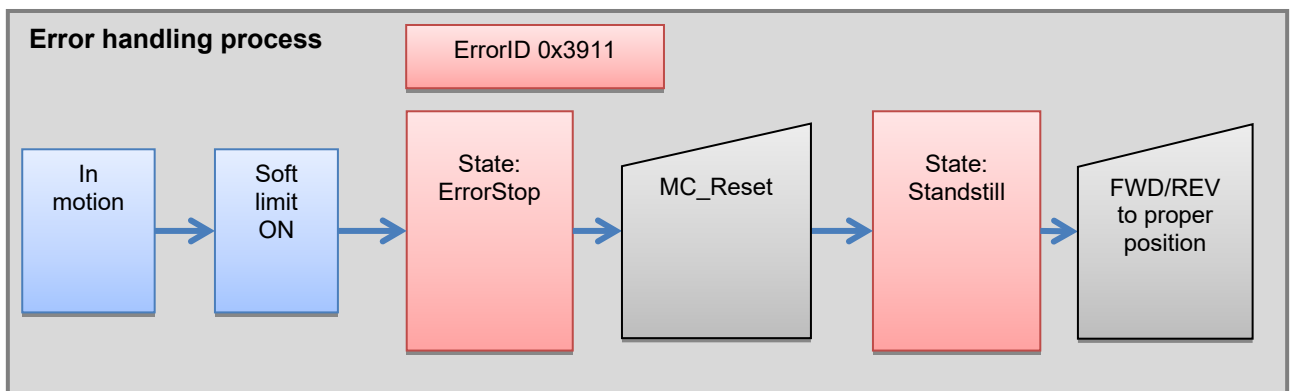

### 9.5.2. Hardware limit errors

When the servo drive is driving a motion, the servo will stop when CWL(Clockwise limit) or CCWL(Counterclockwise limit) is On, no matter it's running forward or reversely. AL014(CWL) or AL015(CCWL) will indicate such error.

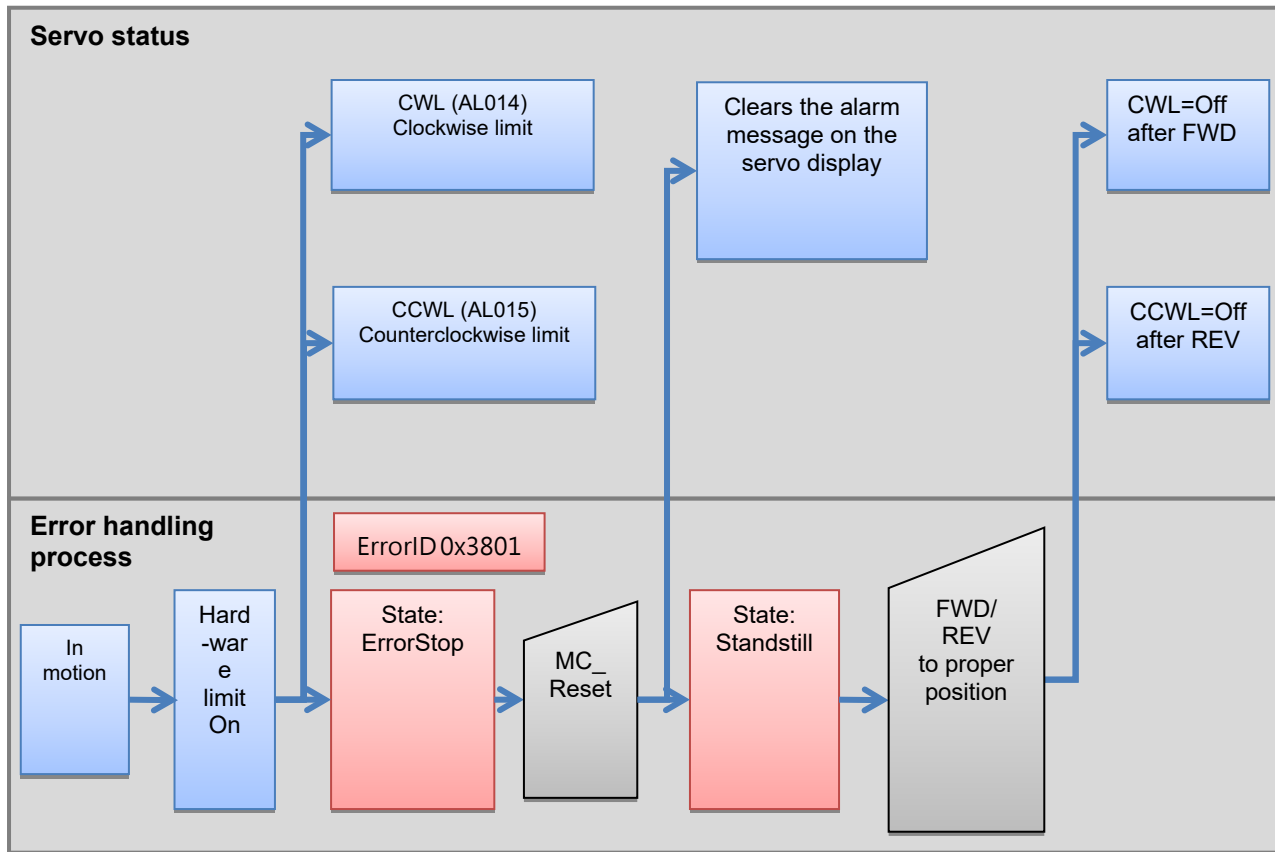



---

# Appendices

## Table of Contents

<b>A.1</b>	<b>Installing the USB Driver for an AH Motion CPU on Windows 7 .....</b>	<b>A-2</b>
<b>A.2</b>	<b>Device Addresses .....</b>	<b>A-5</b>
<b>A.3</b>	<b>Operating Principles of the CPU Module.....</b>	<b>A-7</b>
A.3.1	Operation of the CPU Module.....	A-7
A.3.2	Operating Modes of the CPU Module.....	A-9

## A.1 Installing the USB Driver for an AH Motion CPU on Windows 7

**A1**

The following example demonstrates the installation of the USB driver in Windows 7. For the installation in other operating system, please refer to the relevant description regarding hardware installation in the operation system.

- (1) Confirm AH Motion CPU is powered on normally, and AH Motion CPU is connected to the PC's USB port through the USB cable. Make sure the USB device (CP210x USB UART Bridge Controller) in the Device Manager shows a yellow bang, which indicates that you need to install USB driver. Refer to the following installation steps.

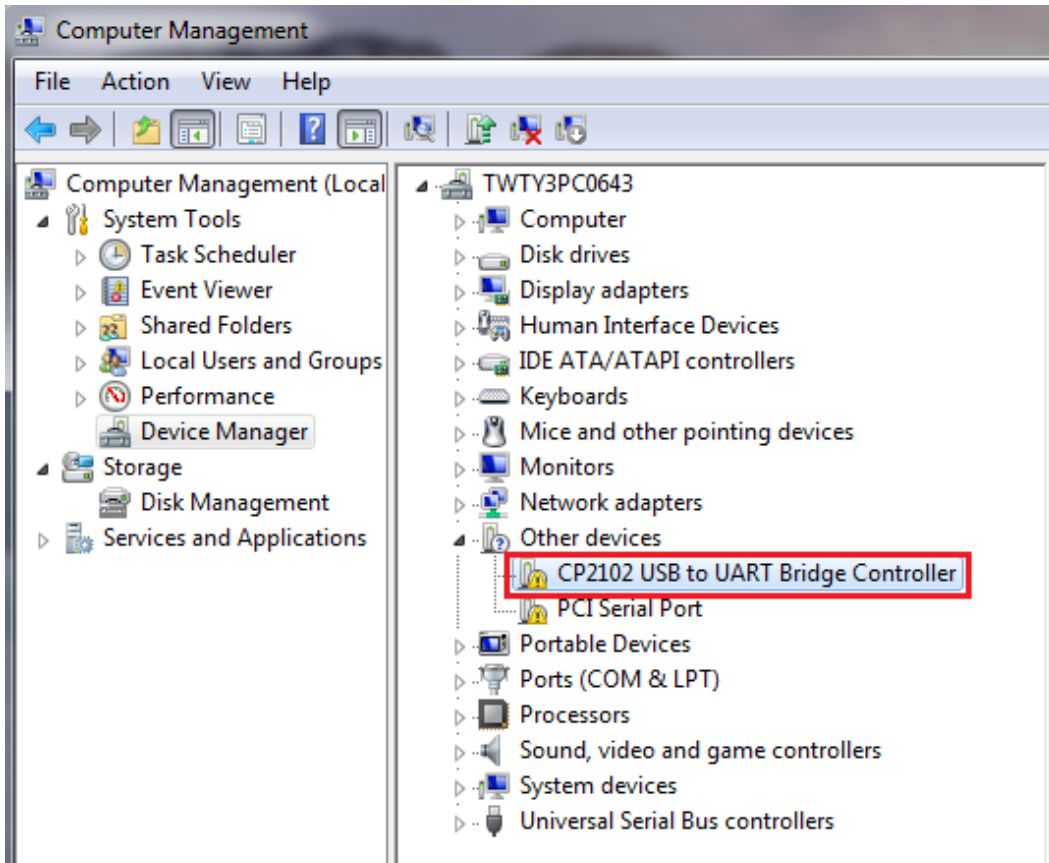
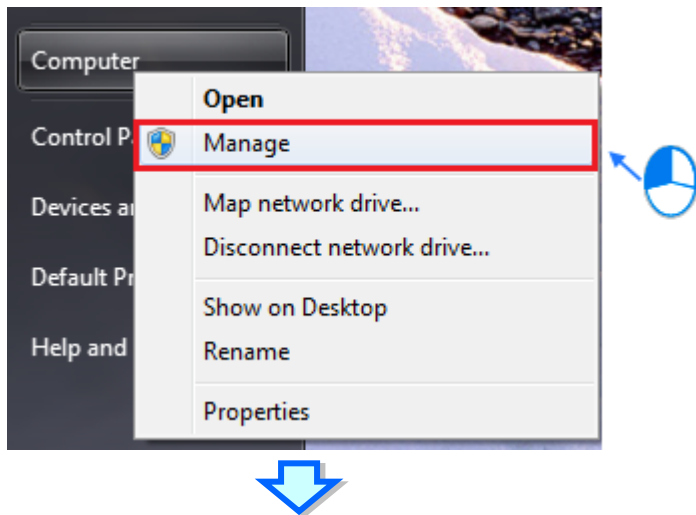

- (2) Find in the ISPSOft installation path and double-click the left button to execute the installation:

\ Driver \ CP210x\_VCP \ CP210xVCPInstaller\_x64.exe installation or

\ Driver \ CP210x\_VCP \ CP210xVCPInstaller\_x86.exe installation; according to the OS.

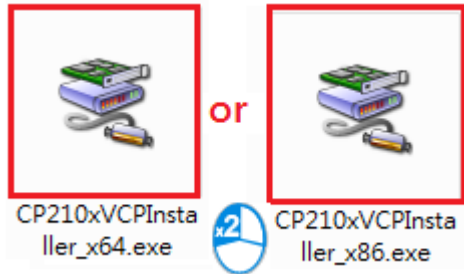

- (3) An installation window will pop up, press Next.

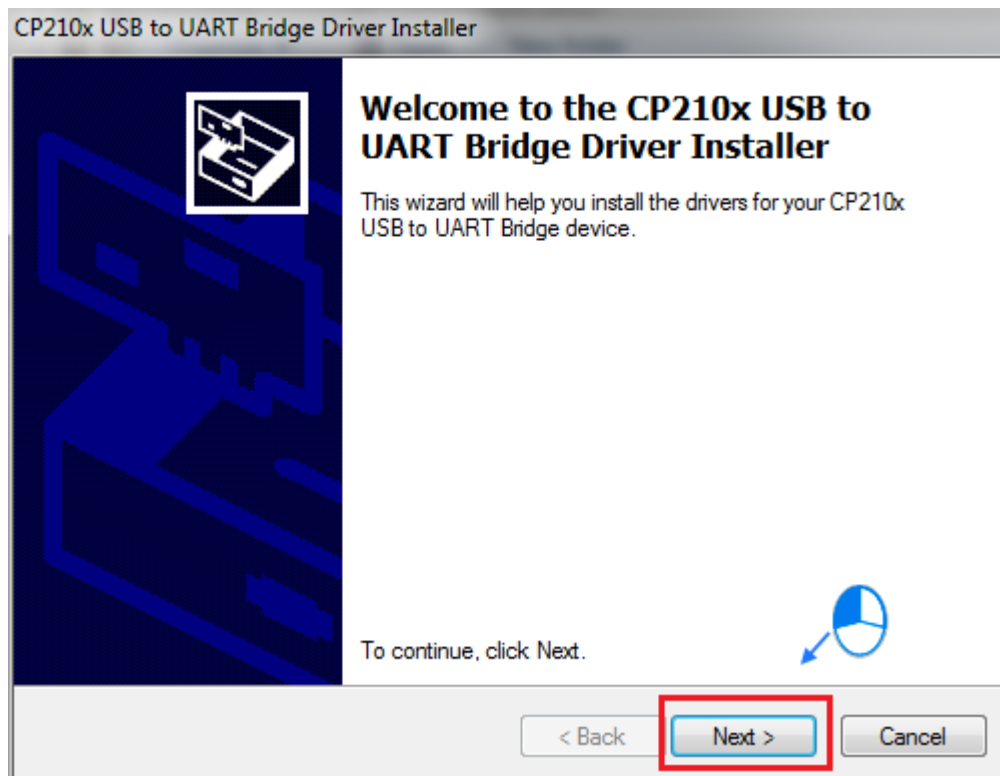

**A1**

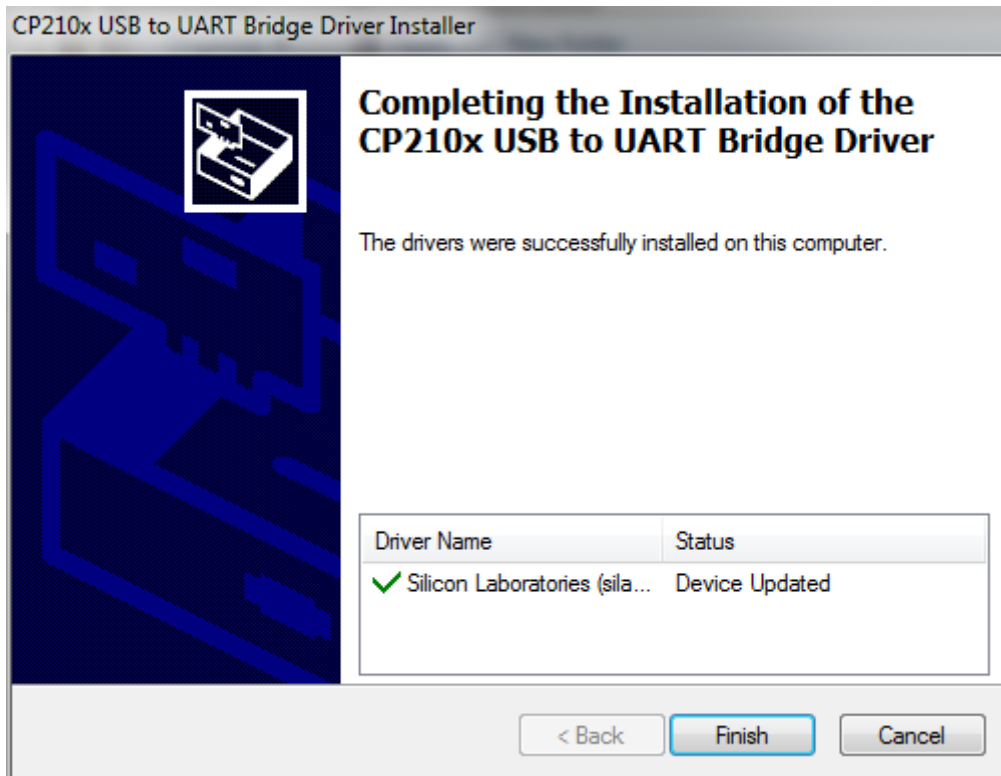

- (4) Confirm whether the USB device (CP210x USB UART Brige Controller) has no yellow bang and display "Silicon Labs CP210x USB to UART Bridge" in Device Manager. If the yellow bang disappeared, it means the installation was successful.

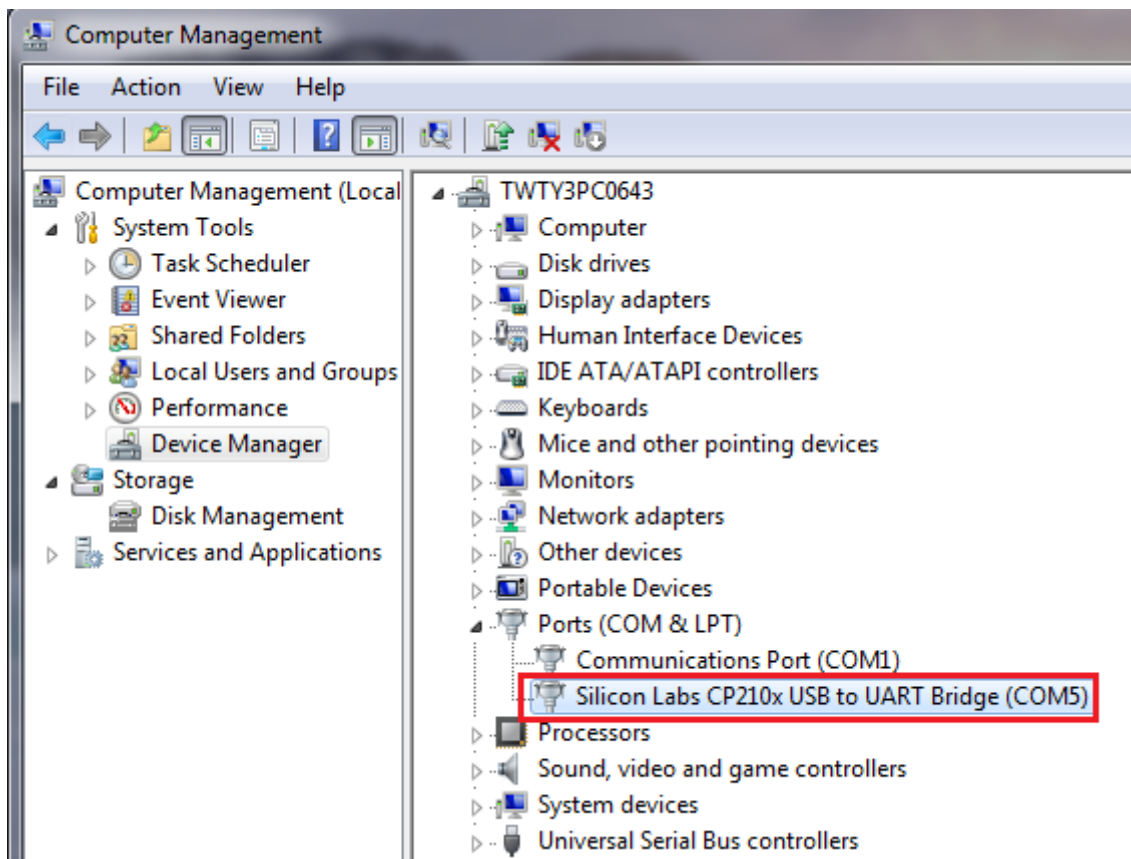

## A.2 Device Addresses

Standard Modbus addresses of devices:

Device	Type	Format	Device range	Modbus address (Decimal number)	AH500 Address (Hexadecimal number)
X	Bit	DDD.D	X0.0~X511.15	124577~132768	6000~7FFF
	Word	DDD	X0~X511	332769~333280	8000~81FF
Y	Bit	DDD.D	Y0.0~Y511.15	040961~049152	A000~BFFF
	Word	DDD	Y0~Y511	440961~441472	A000~A1FF
M	Bit	DDDD	M0~M8191	000001~008192	0000~1FFF
SM	Bit	DDDD	SM0~SM2047	016385~018432	4000~47FF
SR	Word	DDDD	SR0~SR2047	449153~451200	C000~C7FF
D	Word	DDDDD	D0~D32767	400001~432768	0000~7FFF
S	Bit	DDDD	S0~S2047	020481~022528	5000~57FF
T	Bit	DDDD	T0~T2047	057345~059392	E000~E7FF
	Word	DDDD	T0~T2047	457345~459392	E000~E7FF
C	Bit	DDDD	C0~C2047	061441~063488	F000~F7FF
	Word	DDDD	C0~C2047	461441~463488	F000~F7FF
HC	Bit	DD	HC0~HC63	064513~064576	FC00~FC3F
	DWord	DD	HC0~HC63	464513~464576	FC00~FC3F
E	Word	DD	E0~E31	465025~465056	FE00~FE1F

AHxxEMC Modbus addresses of devices:

Device	Type	Format	Device range	AHxxEMC address (Hexadecimal number)
X	Bit	DDD.D	X0.0~X511.15	00006000~00007FFF
	Word	DDD	X0~X511	00008000~000081FF
Y	Bit	DDD.D	Y0.0~Y511.15	0000A000~0000BFFF
	Word	DDD	Y0~Y511	0000A000~0000A1FF
M	Bit	DDDD	M0~M8191	00000000~00001FFF
SM	Bit	DDDD	SM0~SM2047	00004000~000047FF
SR	Word	DDDD	SR0~SR2047	0000C000~0000C7FF
D	Bit	DDDDD.D	D0.0~D65535.15	10000000~100FFFFF
	Word	DDDDD	D0~D32767	00000000~00007FFF
			D32768~D65535	20008000~2000FFFF
S	Bit	DDDD	S0~S2047	00005000~000057FF
T	Bit	DDD	T0~T2047	0000E000~0000E7FF
	Word	DDD	T0~T2047	0000E000~0000E7FF
C	Bit	DDD	C0~C2047	0000F000~0000F7FF
	Word	DDD	C0~C2047	0000F000~0000F7FF



HC	Bit	DD	HC0~HC63	0000FC00~0000FC3F
	DWord	DD	HC0~HC63	0000FC00~0000FC3F
E	Word	DD	E0~E31	0000FE00~0000FE1F
L	Bit	DDDDD.D	L0.0~L65535.15	52000000~520FFFFFF
	Word	DDDDD	L0~L65535	62000000~6200FFFF
AM	Bit	DDDDD	AM0~AM16383	90000000~90003FFF
AR	Bit	DDDDD.D	AR0.15~AR65535.15	90000000~90003FFF
	Word	DDDDD	AR0~AR65535	91000000~9100FFFF
AC	Bit	DD	AC0~AC55	92000000~92000037
	DWord	DD	AC0~AC55	92000000~92000037

**A1**

## A.3 Operating Principles of the CPU Module

### A.3.1 Operation of the CPU Module

#### ● Procedure

The operation of the CPU module is described below.

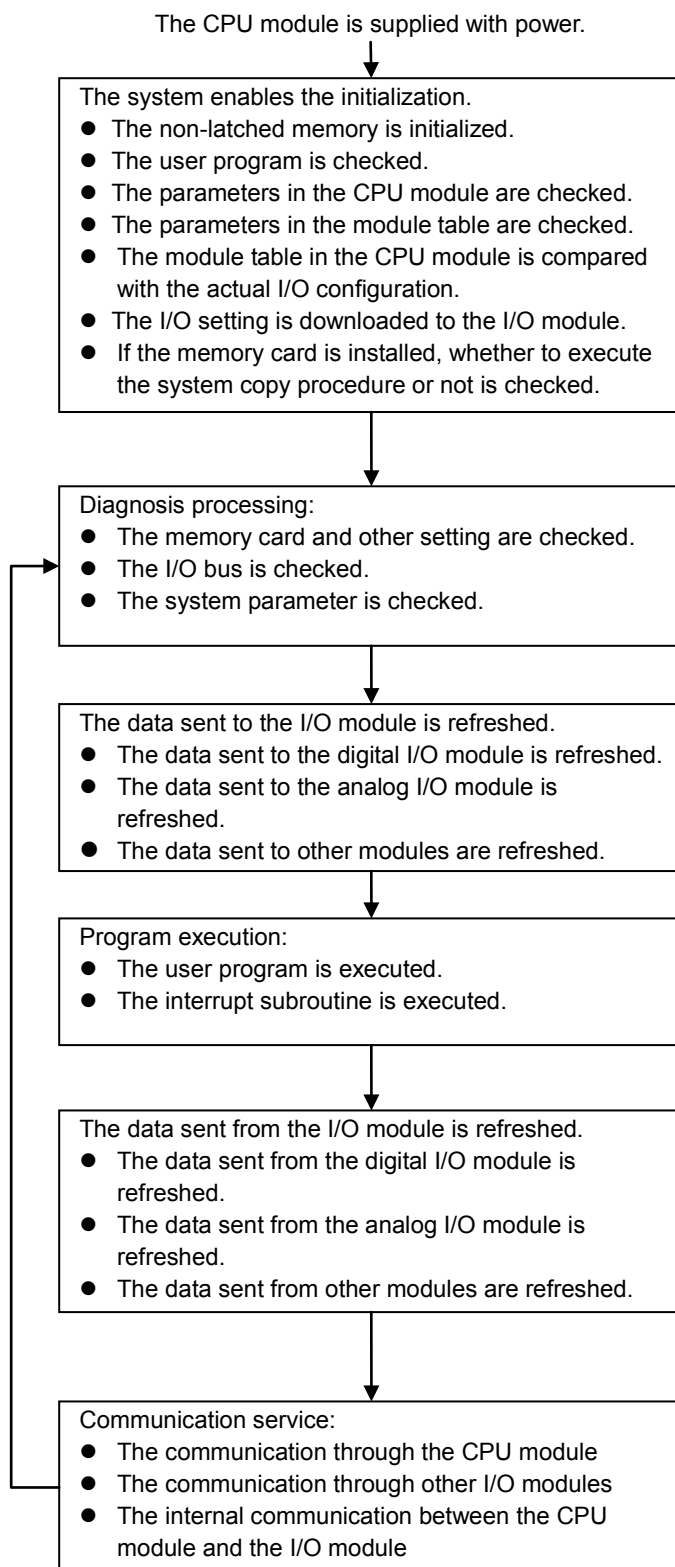

● **I/O Refreshing and Communication Service**

**I/O refreshing**

**A1**

A CPU module reads external I/O data periodically or output data to external I/O. I/O refreshing includes the following.

- Refreshing data in a digital I/O module
- Refreshing data in an analog I/O module
- Refreshing data in a network module
- Refreshing data in a motion control module

All I/O refreshing is executed in the same loop. The data in an input device is refreshed before a program is executed, and the data in an output device is refreshed after the program is executed.

Unit	Maximum data exchange	Data exchange area
Digital I/O module	It depends on the number of input/output channels in the unit.	Input relay/Output relay
Analog I/O module	It depends on the number of input/output channels in the unit.	Data register
Network module	It depends on the unit.	Data register
Motion control module	It depends on the unit.	Data register

**Communication service**

Communication service is nonscheduled communication service of a network module. It includes the communication request sent from external equipment to a CPU module, and the communication request sent from the CPU module to the external equipment.

## A.3.2 Operating Modes of the CPU Module

### ● Operating Modes

There are two operating modes. They can be used to control a user program and all tasks.

**STOP mode:** A program is not executed under this mode. Users can download a module table, initialize CPU configuration and other setting, download a program, check a program, and force a bit ON/OFF.

**RUN mode:** A program is executed under this mode. Users can not download a module table, and initialize CPU configuration and other setting.

### ● Statuses and Operation under Different Operating Mode

The STOP mode and the RUN mode are modes for a CPU module. The statuses and operation under these modes are listed below.

#### ■ Basic operation

CPU mode	Program	I/O refreshing	External output	Program memory	
				Non-latched area	Latched area
STOP	The execution of the program stops.	The I/O refreshing is executed.	OFF (If users set the I/O module so that the final state of the external output on the I/O module is retained, the final state of the external output on the I/O module will be retained.)	The data in the program memories are retained.	
RUN	The program is executed.	The I/O refreshing is executed.	The external output is controlled by the program.	The program memories are controlled by the program.	

**A3**

#### ■ Relation between the operating modes and the tasks

Mode	Loop task	Interrupt task
STOP	The execution of the loop task stops.	The execution of the interrupt task stops.
RUN	<ul style="list-style-type: none"> <li>● The tasks which have not been executed are in the halt state.</li> <li>● If a task is active, or the instruction TKON is executed, the task is executed.</li> <li>● If a task is not active, or the instruction TKOFF is executed, the task is not executed.</li> </ul>	If the condition of the interrupt is met, the task is executed.

#### ■ Relation between the change of the modes and the program memory

Change of the mode	Non-latched area	Latched area
STOP→RUN	Whether the data is cleared or retained depends on user's setting.	The data is retained.
RUN→STOP	The data is retained.	The data is retained.

**MEMO**

**A1**