



# MS300/MH300 CMM-PN02 PROFINET Communication Card Operation Manual

## Application

Drive Firmware Version: MS300 V2.02 / MH300 V2.00 or above

CMM- PN02 Comm. Card Firmware Version: V1.0.1 or above



<http://www.delta.com.tw/industrialautomation>

2023-09-26



## Caution

- ✓ This operation manual provides information on specifications, installation instructions, basic operations/configurations, and details on network communication protocols.
- ✓ The AC motor drive is a sophisticated product powered by electricity. For the safety of the operator and your mechanical equipment, only qualified electrical engineers can perform the installation/test runs and make parameter adjustments. If you have any question or concern, please contact your local Delta distributor. Our professional staff will be very glad to help you.
- ✓ Please read this manual carefully and follow the instructions completely to avoid device damage or personal injury.

# Table of Contents

<b>1</b>	<b>Introduction .....</b>	<b>4</b>
1.1	Introduction to PROFINET IO Communication .....	4
1.2	Features .....	4
1.3	Network Functions and Specifications.....	4
<b>2</b>	<b>Product Appearance and Components .....</b>	<b>6</b>
2.1	Exterior Dimensions.....	6
2.2	Introduction to Each Component.....	6
2.3	LED Indicators .....	7
2.4	Definition of RJ45 Pin .....	7
2.5	MAC Address Definition .....	8
<b>3</b>	<b>Installation and Wiring.....</b>	<b>9</b>
3.1	Mounting Position of Communication Cards.....	9
3.2	Communication Cable.....	10
3.3	MS300 Installation .....	11
3.4	MH300 Installation .....	13
3.5	Connecting to the Network.....	16
<b>4</b>	<b>MH300/MS300 Drive Settings .....</b>	<b>17</b>
<b>5</b>	<b>PROFINET Communication Profile .....</b>	<b>18</b>
5.1	Profinet comm. card info. (Identification & Maintenance functions (I&M)).....	18
5.2	MS300/MH300 real-time data access method(List of control words and status words) .....	19
5.3	Motor Drive Handling when Disconnection.....	21
<b>6</b>	<b>Connection Configuration to Host Controller.....</b>	<b>23</b>
6.1	Basic Configuration.....	23
6.2	Speed Mode DEMO (S7-300 + STEP 7) .....	28
6.3	Speed Mode DEMO (S7-1500 + TIA PORTAL) .....	38
<b>6.4</b>	<b>Demonstration of Reading/Writing Synchronous and Asynchronous Parameters (S7-300 + TIA PORTAL).....</b>	<b>48</b>

# 1 Introduction

## 1.1 Introduction to PROFINET IO Communication

PROFINET IO is a fieldbus, a family of industrial computer network protocols, and serves as a communication between programmable logic controllers (PLC) and distributed field equipment for EtherNet. This protocol recognizes three classes of devices, IO Controllers, IO Supervisors and IO Devices, and uses three different communication channels to exchange data: Standard UDP/IP & TCP/IP Channel, Real-Time (RT) Channel, and Isochronous Real-Time (IRT) Channel. **Standard UDP/IP & TCP/IP Channel** is used to parameterize and configure device and asynchronous operation; **RT Channel** is used for synchronous data transmission and warning; **IRT Channel** is applied to motion control.

## 1.2 Features

CMM-PN02 connects MS300/MH300 drive to PROFINET to exchange data with the host controller easily. This simple network solution saves cost and time for connection and installation of factory automation. Moreover, its components are compatible with suppliers'.

By installing CMM-PN02 in MS300/M300 through the main PROFINET device, you can:

1. Control the drive through PROFINET
2. Modify the drive's parameters through PROFINET
3. Monitor the drive's status through PROFINET

## 1.3 Network Functions and Specifications

### ■ EtherNet Specifications

Item	Specifications
Interface	RJ45
Number of ports	2 ports
Communication Mode	IEEE 802.3
Cable	Category 5e shielding 100 M
Transmission speed	10/100 Mbps auto-negotiate
Communication protocol	PROFINET

### ■ Environmental Conditions

Item	Specifications
Noise immunity	ESD (IEC 61800-5-1, IEC 6100-4-2) EFT (IEC 61800-5-1, IEC 6100-4-4) Surge Test (IEC 61800-5-1, IEC 6100-4-5) Conducted Susceptibility Test (IEC 61800-5-1, IEC 6100-4-6)
Operating temperature	-10–50°C (temperature), 90% (humidity)
Storage temperature	-25–70°C (temperature), 95% (humidity)
Vibration/Shock resistance	International standards IEC 61800-5-1, IEC 60068-2-6/IEC 61800-5-1, IEC 60068-2-27

**■ Electrical Specifications**

<b>Item</b>	<b>Specifications</b>
Power supply voltage	5 V <sub>DC</sub>
Power consumption	0.8 W
Insulation voltage	500 V <sub>DC</sub>
Weight (g; approx.)	27 (g)

## 2 Product Appearance and Components

### 2.1 Exterior Dimensions

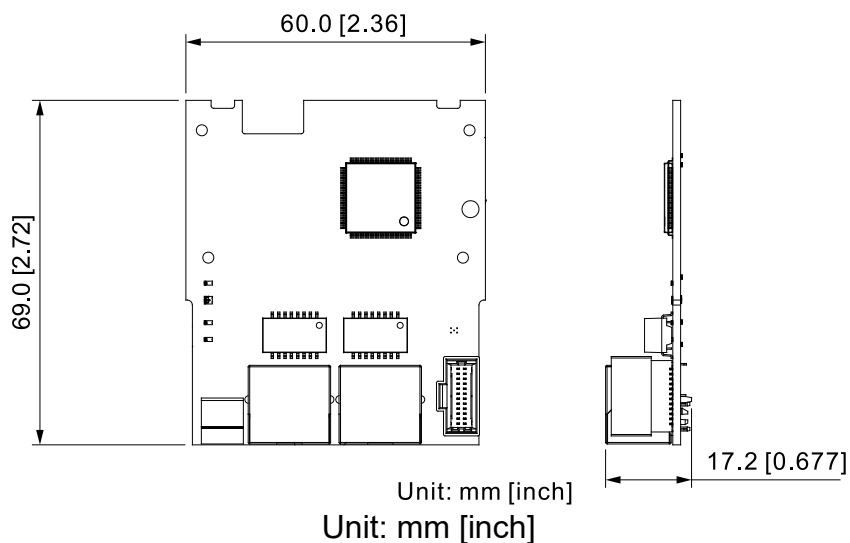

### 2.2 Introduction to Each Component

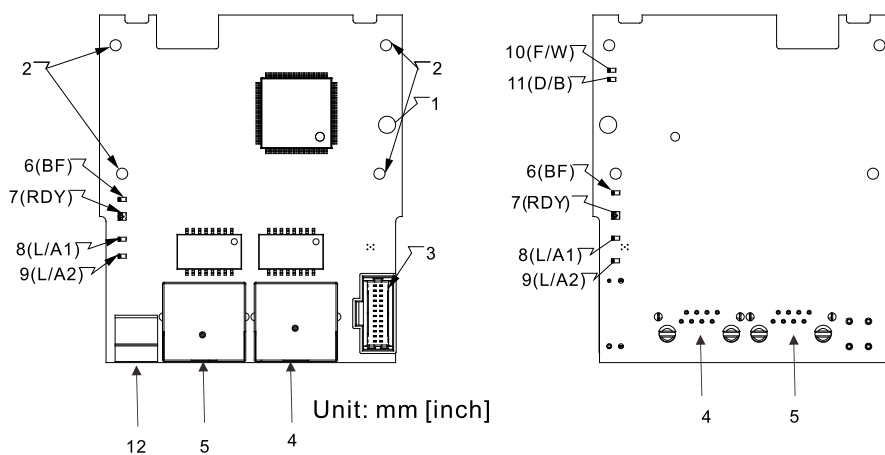

- |  |                                 |
|--|---------------------------------|
| 1. Screw fastening hole                    | 9. Link PHY2 indicator (Port 2) |
| 2. Positioning hole for communication card | 10. F/W indicator               |
| 3. Control Panel connection port           | 11. D/B indicator               |
| 4. RJ45 connection port (Port 2)           | 12. PE grounding terminal       |
| 5. RJ45 connection port (Port 1)           |                                 |
| 6. BF out indicator                        |                                 |
| 7. Ready out indicator                     |                                 |
| 8. Link PHY1 indicator (Port 1)            |                                 |

## 2.3 LED Indicators

Name	Indicator Status	Indication	
BF (bus fault) indicator	Red LED	Always on	Disconnected with PROFINET Controller
		Flashing	Normal connection, but abnormal communication with PROFINET Controller.
		Off	Normal connection with PROFINET Controller
RDY indicator	Red/Green LED	Always orange	PROFINET diagnostic
		Always green	PROFINET card ready.
L/A1 (Link/ Act1) indicator	Green LED	Always on	L/A1 has network signal.
		Flashing	L/A1 is handshaking data.
		Off	L/A1 doesn't have network signal.
L/A2 (Link' Act2) indicator	Green LED	Always on	L/A2 has network signal.
		Flashing	L/A2 is handshaking data
		Off	L/A2 doesn't have network signal.

## 2.4 Definition of RJ45 Pin

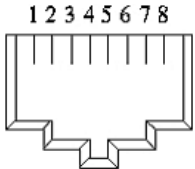
RJ45 Pinout Diagram	PIN	Definition	Description
	1	Tx+	Positive pole for data transmission
	2	Tx-	Negative pole for data transmission
	3	Rx+	Positive pole for receiving data
	4	--	N/C
	5	--	N/C
	6	Rx-	Negative pole for receiving data
	7	--	N/C
	8	--	N/C

## 2.5 MAC Address Definition

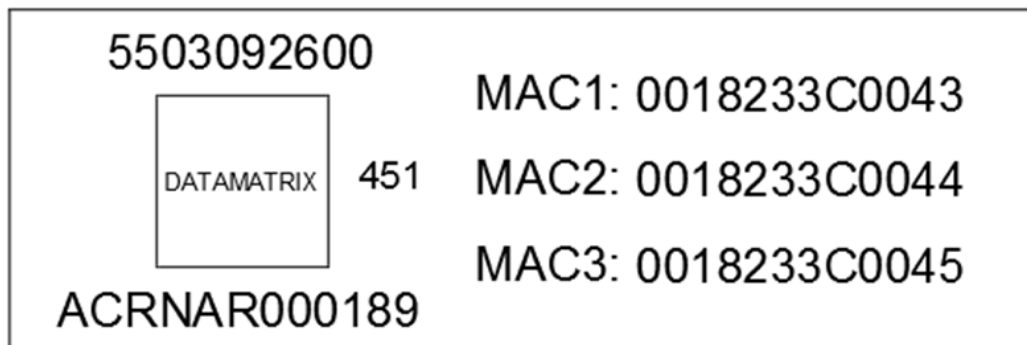

Definition	Description
MAC1	Port 1 MAC Address
MAC2	Port 2 MAC Address
MAC3	Interface MAC Address



### 3 Installation and Wiring

This section introduces how CMM-PN02 connects to MS300/MH300 and to network.

#### 3.1 Mounting Position of Communication Cards

- MS300 Mounting Position of Communication Card

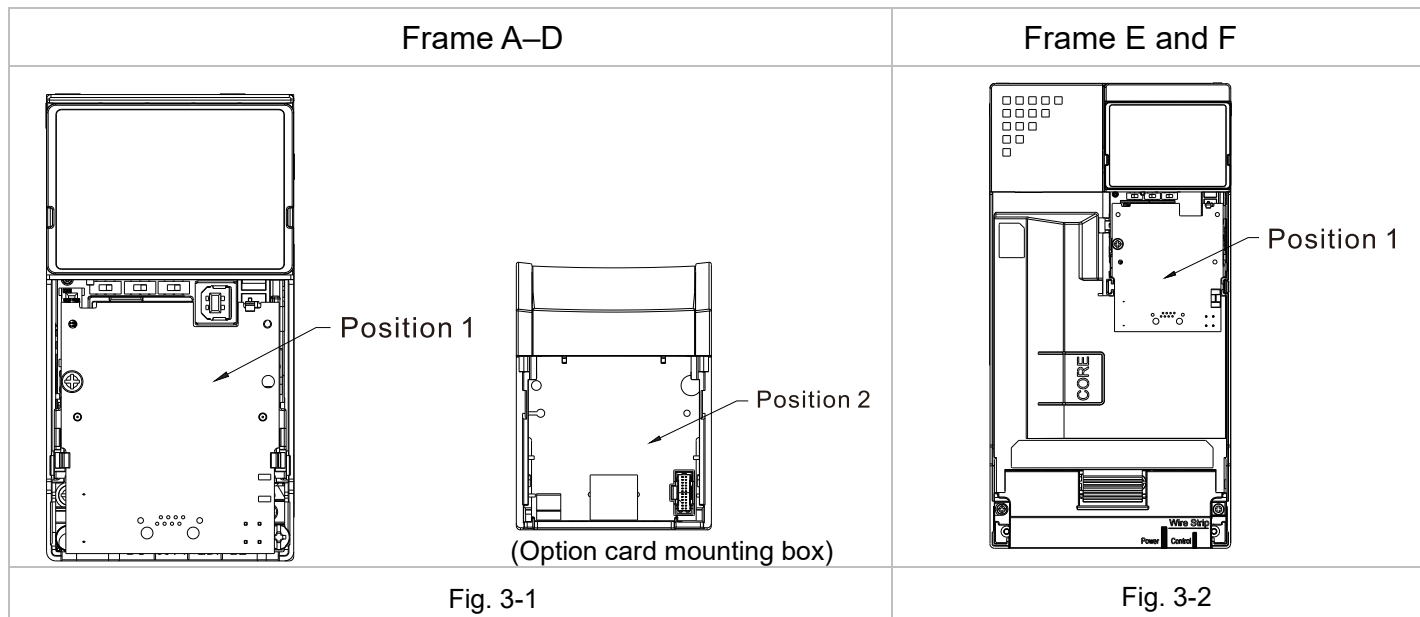

- MH300 Mounting Position of Communication Card

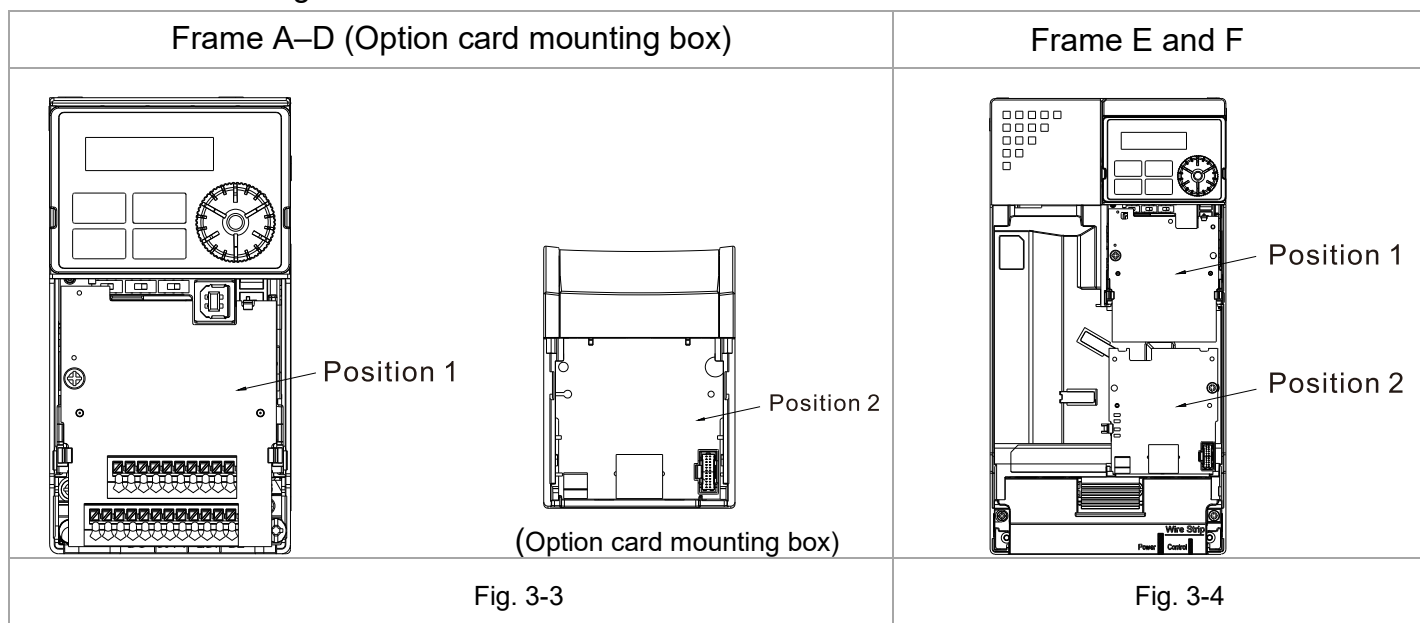

### 3.2 Communication Cable

- Three types of cable length are available. As shown in the Fig.3-5, there are numbers on two ends of the communication cable near the connector. The connection methods of the communication card for different frames are shown in the table below. Read the descriptions and numbers on the cables before wiring.

Frame	Mounting Position 1		Mounting Position 2	
	Connect to control board connector	Connect to communication card connector	Connect to control board connector	Connect to communication card connector
A	1	2	3	4
B	1	2	3	4
C	3	4	3	4
D	5	6	5	6
E	3	4	3	4
F	3	4	3	4

Number 1, 3, 5: Connect to  
control board connector

Number 2, 4, 6: Connect to  
communication card connector

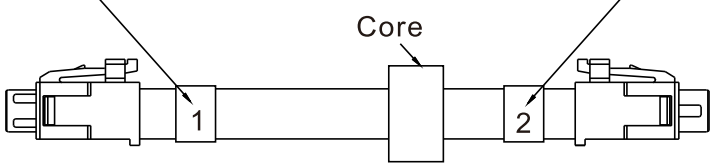

Fig. 3-5

### 3.3 MS300 Installation

#### 3.3.1 MS300 Mounting Position 1 (See Section 3.1 for Details on Mounting Position) - Frame A–F

Installation method: **Back-mount** the communication card by connecting **flat cables** to the control board.

- Turn off the power of the motor drive, and then remove the front cover, as shown in Fig.3-6.
- Assemble the connection cable: Connect the connector at one end of the connection cable to the control board connector. Refer to Section 3.2 for more information on connection methods.
- Assemble the supported frame of the option card: Aim the two clips at the two slots on the motor drive, and then press downward to have the two clips engage the slots, as shown in Fig.3-7.
- Assemble the connection cable: Connect the connector at the other end of the connection cable to the connector of the communication card.
- Assemble the communication card: Have the terminal block and connector of the communication card face downward, aim the two holes of the communication card to the position column and press downward so that the three clips engage the communication card, as shown in Fig.3-8.
- Make sure that three clips properly engage the communication card and then tighten the screws (suggested torque value: 4–6 kg-cm [3.5–5.2 lb-in.] [0.39–0.59 Nm]), as shown in Fig.3-9.
- Assembly is completed, as shown in Fig.3-10.

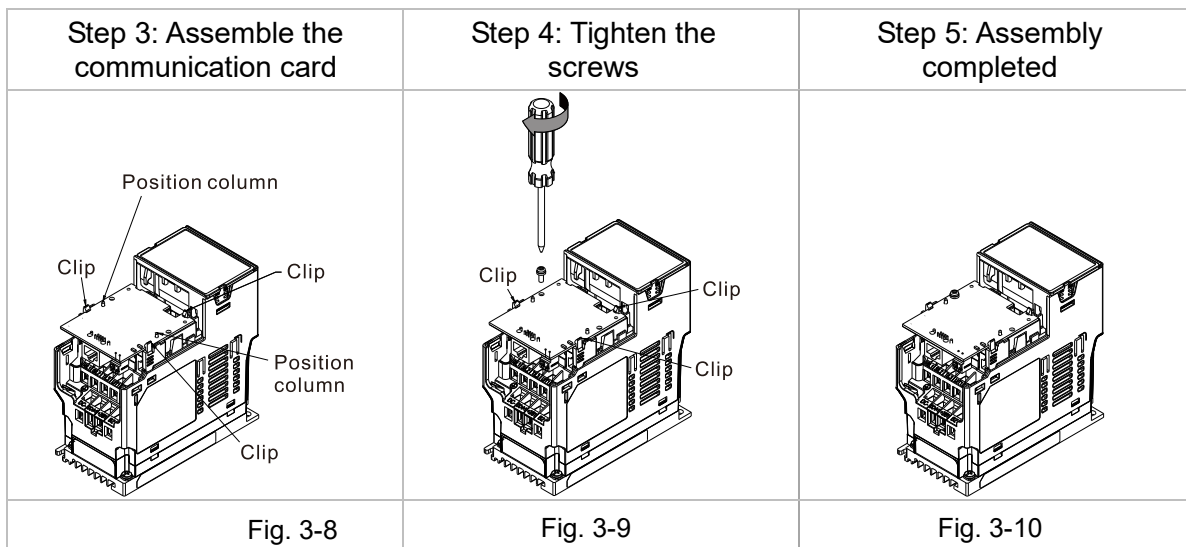
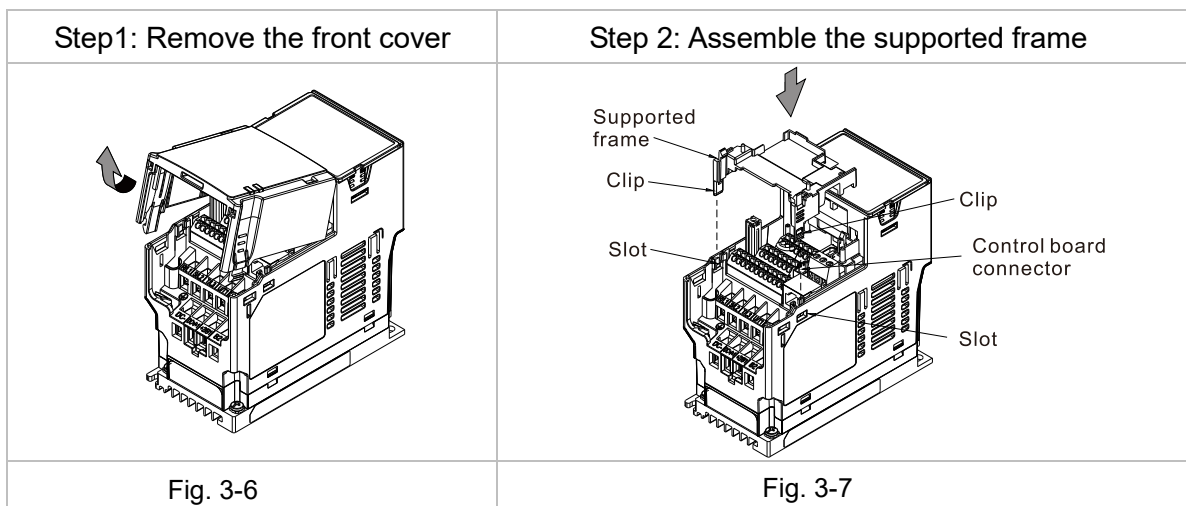

### 3.3.2 MS300 Mounting Position 2 (See Section 3.1 for Details on Mounting Position) - Frame A–D (Not Applicable for Frame E and F)

Installation method: **Front-mount** the communication card by connecting **flat cables** to the control board.

- Turn off the power of the motor drive, and then remove the front cover, as shown in Fig.3-11.
- Assemble the communication card: Detach the upper cover of the mounting box for the communication card by slipping and make the terminal block and connector of the communication card face upward. Fix the front end of the communication card to the slots, and then rotate it, as shown in the Fig.3-12.
- Make sure that two clips properly engage the communication card on the backside, and then tighten the screws (suggested torque value: 4–6 kg-cm [3.5–5.2 lb-in.] [0.39–0.59 Nm]), as shown in Fig.3-13.
- Assemble the connection cable: Connect the connector at one end of the connection cable to the control board connector. Refer to Section 3.2 for more information on connection methods.
- Attach the front cover of the drive.
- Assemble the connection cable: Connect the connector at the other end of the connection cable to the connector of the communication card.
- Attach the upper cover to the mounting box for the option card, as shown in Fig.3-14.
- Assemble the mounting box for the option card: Aim the four clips of the mounting box for the option card at the slots on the upper cover of the motor drive, and then press downward to have the four clips engage the slots, as shown in the Fig.3-15.
- Assembly is completed, as shown in Fig.3-16.

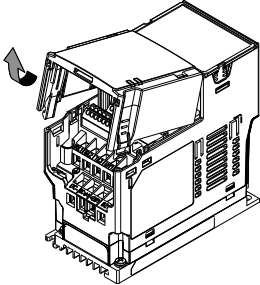
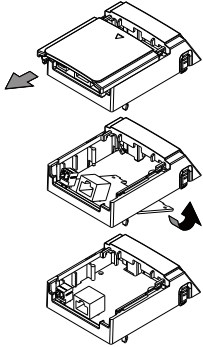
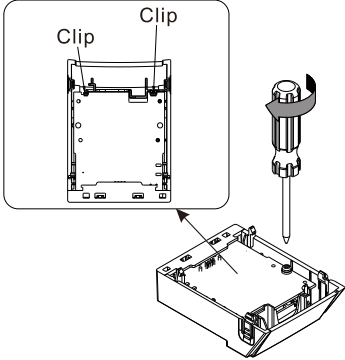
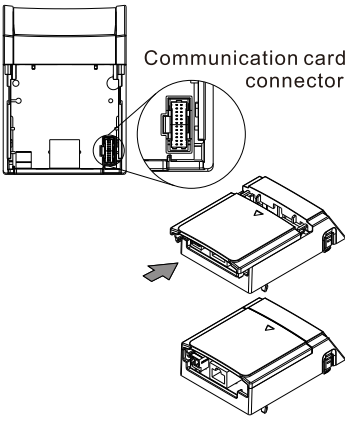
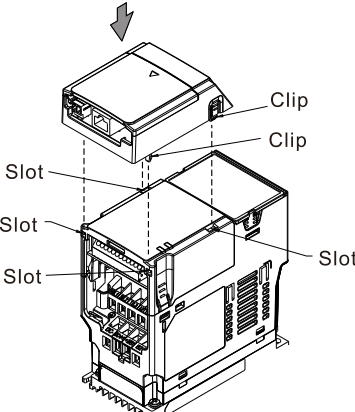
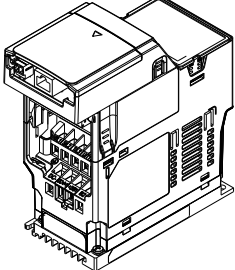
<p>Step 1: Remove the front cover</p>  <p>Fig. 3-11</p>	<p>Step 2: Assemble the communication card</p>  <p>Fig. 3-12</p>	<p>Step 3: Tighten the screws</p>  <p>Fig. 3-13</p>
<p>Step 4: Attach the upper cover to the mounting box</p>  <p>Fig. 3-14</p>	<p>Step 5: Assemble the mounting box for the option card</p>  <p>Fig. 3-15</p>	<p>Step 5: Assembly completed</p>  <p>Fig. 3-16</p>

### 3.4 MH300 Installation

#### 3.4.1 MH300 Mounting Position 1 (See Section 3.1 for Details on Mounting Position) - Frame A–F

Installation method: **Back-mount** the communication card by connecting **flat cables** to the control board.

- Turn off the power of the motor drive, and then remove the front cover, as shown in Fig.3-17.
- Assemble the connection cable: Connect the connector at one end of the connection cable to the control board connector. Refer to Section 3.2 for more information on connection methods.
- Assemble the supported frame of the option card: Aim the two clips at the two slots on the motor drive, and then press downward to have the two clips engage the slots, as shown in Fig.3-18.
- Assemble the connection cable: Connect the connector at the other end of the connection cable to the connector of the communication card.
- Assemble the communication card: Have the terminal block and connector of the communication card face downward, aim the two holes of the communication card to the position column and press downward so that the three clips engage the communication card, as shown in Fig.3-19.
- Make sure that three clips properly engage the communication card, and then tighten the screws (suggested torque value: 4–6 kg-cm [3.5–5.2 lb-in.] [0.39–0.59 Nm]), as shown in Fig.3-20.
- Assembly is completed, as shown in Fig.3-21.

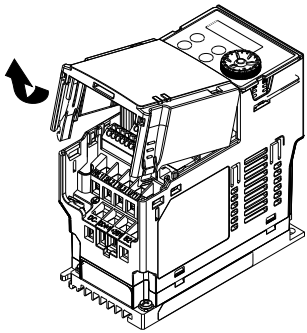
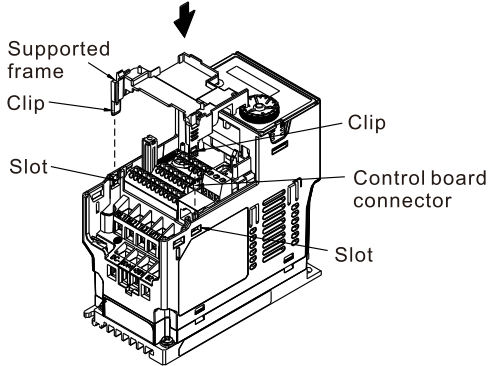
Step1: Remove the front cover	Step 2: Assemble the supported frame
	
Fig. 3-17	Fig. 3-18

### 3.4.2 MH300 Mounting Position 2 (See Section 3.1 for Details on Mounting Position) - Frame A-D

Installation method: **Front-mount** the communication card by connecting **flat cables** to the control board.

- Turn off the power of the motor drive, and then remove the front cover, as shown in Fig.3-22.
- Assemble the communication card: Detach the upper cover of the mounting box for the communication card by slipping and make the terminal block and connector of the communication card face upward. Fix the front end of the communication card to the slots, and then rotate it, as shown in the Fig.3-23.
- Make sure that two clips properly engage the communication card on the backside, and then tighten the screws (suggested torque value: 4–6 kg-cm [3.5–5.2 lb-in.] [0.39–0.59 Nm]), as shown in Fig.3-24.
- Assemble the connection cable: Connect the connector at one end of the connection cable to the control board connector. Refer to Section 3.2 for more information on connection methods.
- Attach the front cover of the drive.
- Assemble the connection cable: Connect the connector at the other end of the connection cable to the connector of the communication card.
- Attach the upper cover to the mounting box for the option card, as shown in Fig.3-25.
- Assemble the mounting box for the option card: Aim the four clips of the mounting box for the option card at the slots on the upper cover of the motor drive, and then press downward to have the four clips engage the slots, as shown in the Fig.3-26.
- Assembly is completed, as shown in Fig.3-27.

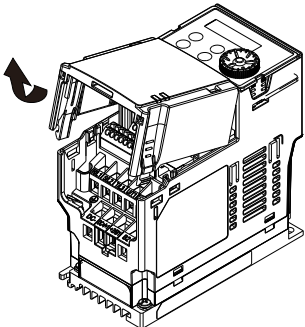
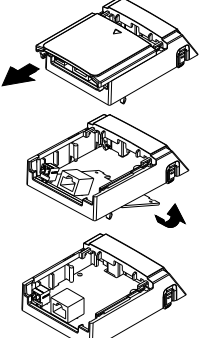
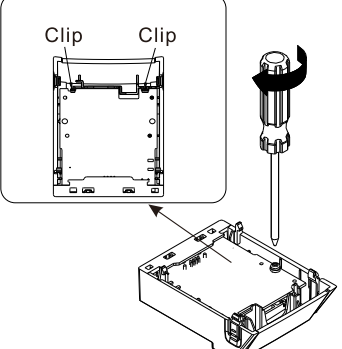
<p>Step1: Remove the front cover</p>	<p>Step 3: Assemble the communication card</p>	<p>Step 4: Tighten the screws</p>
		
<p>Fig. 3-22</p>	<p>Fig. 3-23</p>	<p>Fig. 3-24</p>

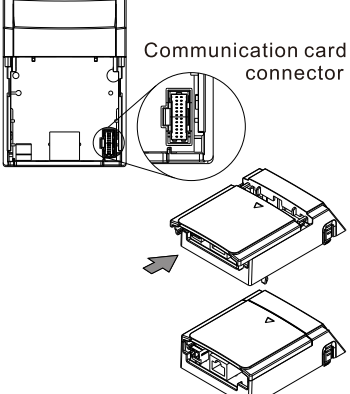
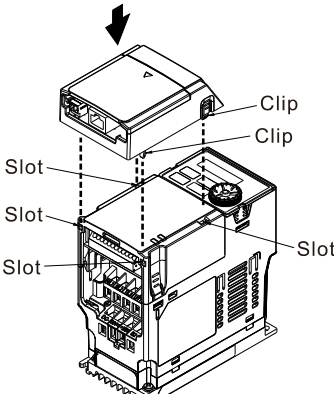
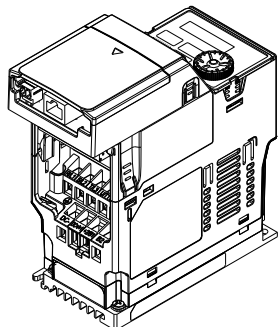
<p>Step 4: Attach the upper cover to the mounting box</p>	<p>Step 5: Assemble the mounting box for the option card</p>	<p>Step 5: Assembly completed</p>
		
<p>Fig. 3-25</p>	<p>Fig. 3-26</p>	<p>Fig. 3-27</p>

### 3.4.3 MH300 Mounting Position 2 (See Section 3.1 for Details on Mounting Position) - Frame E and F

Installation method: **Front-mount** the communication card by connecting **flat cables** to the control board.

- Turn off the power of the motor drive, and then remove the front cover, as shown in Fig.3-28.
- Assemble the connection cable: Connect the connector at one end of the connection cable to the control board connector. Refer to Section 3.2 for more information on connection methods. Wire the cables as Fig.3-29 shows and make sure the core is placed in the groove.
- Assemble the communication card: Have the terminal block and connector of the communication card face upward. Fix the front end of the communication card to the slots, and then rotate it, as shown in the Fig.3-30.
- Make sure that the clip properly engages the communication card, and then tighten the screws (suggested torque value: 4–6 kg-cm [3.5–5.2 lb-in.] [0.39–0.59 Nm]), as shown in Fig.3-31.
- Assemble the connection cable: Connect the connector at the other end of the connection cable to the connector of the communication card, as shown in Fig.3-32.
- Assembly is completed, as shown in Fig.3-33.

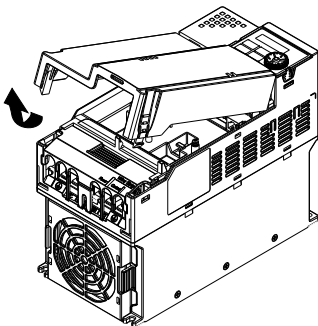
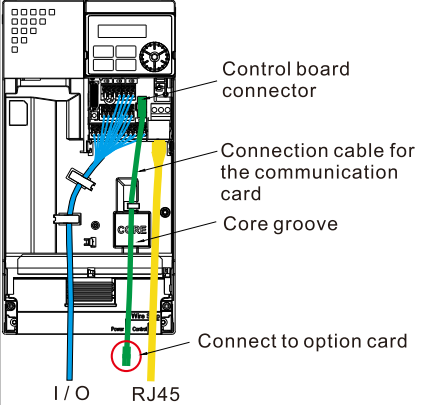
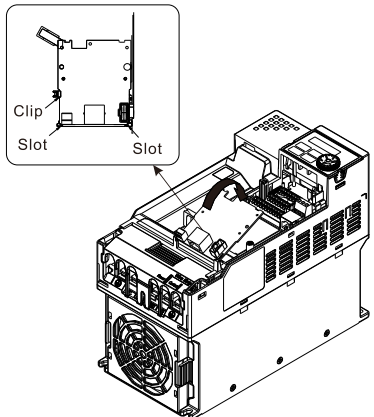
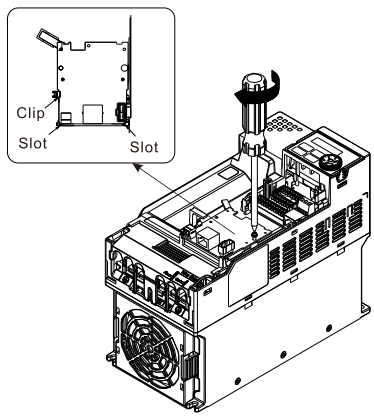
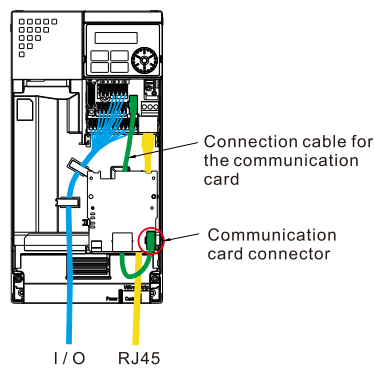
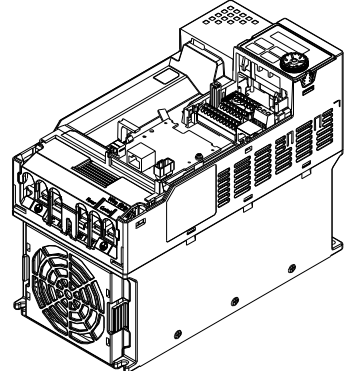
<p>Step1: Remove the front cover</p>  <p>Fig. 3-28</p>	<p>Step 2: Assemble the connection cable</p>  <p>Fig. 3-29</p>	<p>Step 3: Assemble the communication card</p>  <p>Fig. 3-30</p>
<p>Step 4: Tighten the screws</p>  <p>Fig. 3-31</p>	<p>Step 5: Assemble the connection cable</p>  <p>Fig. 3-32</p>	<p>Step 6: Assembly completed</p>  <p>Fig. 3-33</p>

### 3.5 Connecting to the Network

The wiring of CMM-PN02:

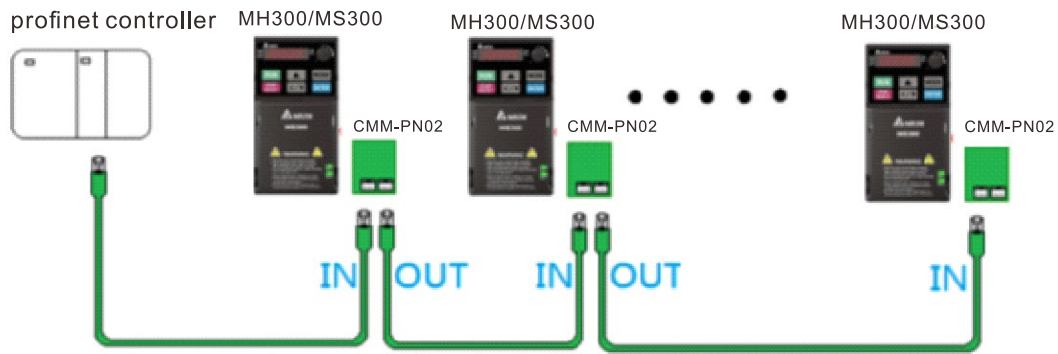

When the installation is finished, supply electricity to the drive. The Pr.09-60 of the drive should be able to display “PROFINET” with a current value of 12. If not, make sure your version of the drive is correct (MS300/MH300 needs v.2.04 or later versions) and the communication card is correctly connected.





## 4 MH300/MS300 Drive Settings

When you operate MS300/MH300 through CMM-PN02, you should set the communication card as the source of MS300/MH300 controls and settings. You need to use the keypad to configure the following parameter addresses to the corresponding values:

Keypad Parameter No.	Settings/ Displayed Value	Description of Function
Pr.00-20	8	Set communication card as the source of frequency command.
Pr.00-21	5	Set communication card as the source of control.
Pr.09-30	1	Decoding method is either 60xx or 20xx.
Pr.09-60	12	Communication card identification: When CMM-PN02 communication card is connected, the value of this parameter displays "12".

**NOTE:** To make PLC or the host controller to identify CMM-PN02, it is necessary to load the product description file of CMM-PN02 (GSDML). You can download it directly from Delta's official website.

## 5 PROFINET Communication Profile

This section describes the general setting model and the way to set the parameters of the motor drives by the host computer through CMM-PN02, refer to the following sections for the actual operations. This section is divided into the following items:

1. PROFINET comm. card info. (Identification & Maintenance functions (I&M))
2. MS300/MH300 real-time data access method
3. Motor drive handling during disconnection in synchronous mode
4. MS300/MH300 parameter reading and writing in non-real-time mode

### 5.1 PROFINET comm. card info. (Identification & Maintenance functions (I&M))

PROFINET provides Identification and Maintenance function (I&M) which supports machinery commissioning, parameter tuning and repairing. CMM-PN02 supports the I&M0 function which can be accessed using a read request from the I&M record.

The following table shows the data structure when I&M0 record is returned:

Content	Size	Description
Header	10 bytes	-
Vendor ID	2 bytes	PROFINET Vendor ID of Delta, which is 0x03FB.
Order ID	20 bytes	Order number
Serial number	16 bytes	Serial number
Hardware revision	2 bytes	Hardware revision
Software revision	4 bytes	Revision of the software (V1.2.3 shows four bytes in "V",1,2,3 sequence)
Revision counter	2 bytes	Number of revisions
Profile ID	2 bytes	0x00
Profile specific type	2 bytes	No profile specific type (0x0000)
I&M version	2 bytes	Version 1.1 (0x0101)
Supported I&M functions	2 bytes	I&M0 is supported (0x0001).

## 5.2 MS300/MH300 real-time data access method(List of control words and status words)

PROFINET communication provides a real-time channel (RT channel) for data transmission. After the host computer establishes this channel with the communication card, it can send and receive the data from the motor drive during a fixed period of time. CMM-PN02 provides the host computer with 60 bytes of input and output data through this channel according to the setting at Pr.09-30 of the motor drive. The corresponding methods are listed in the table below:

Output of host computer	Corresponding Address at the motor drive.	
Address Number	Pr.09-30 = 0	Pr.09-30 = 1
%Q (x + 0) ~ %Q (x + 1)	2000H	6000H
%Q (x + 2) ~ %Q (x + 3)	2001H	6001H
%Q (x + 4) ~ %Q (x + 5)	2002H	6002H
%Q (x + 6) ~ %Q (x + 7)	N/A	6003H
%Q (x + 8) ~ %Q (x + 9)	N/A	6004H
%Q (x + 10) ~ %Q (x + 11)	N/A	6005H
%Q (x + 12) ~ %Q (x + 13)	N/A	6006H
%Q (x + 14) ~ %Q (x + 15)	N/A	N/A
...	N/A	N/A
%Q (x + 40) ~ %Q (x + 41)	user-defined address 1	user-defined address 1
...	user-defined address n	user-defined address n
%Q (x + 54) ~ %Q (x + 55)	user-defined address 8	user-defined address 8
%Q (x + 56) ~ %Q (x + 57)	N/A	N/A
%Q (x + 58) ~ %Q (x + 59)	N/A	N/A

**NOTE 1:** x is the start address set by the host computer.

**NOTE 2:** The Q means output, one motor drive address corresponds to two bytes, and one host computer address corresponds to one byte in order of low byte to high byte.

**NOTE 3:** user-defined address can define the address of the motor drive in the host computer, for example, Pr.04-50 = 16#0432 = 1074, the more addresses are defined, the longer the synchronization time between the motor drive and the host computer. You can define the user-defined address in the TIA portal. Refer to the periodic communication in the next chapter.

Input of host computer	Corresponding Address at the motor drive.	
Address Number	Pr.09-30 = 0	Pr.09-30 = 1
%I (y + 0) ~ %I (y + 1)	2100H	6100H
%I (y + 2) ~ %I (y + 3)	2101H	6101H
%I (y + 4) ~ %I (y + 5)	2102H	6102H
%I (y + 6) ~ %I (y + 7)	2103H	6103H
%I (y + 8) ~ %I (y + 9)	2104H	6104H
%I (y + 10) ~ %I (y + 11)	2105H	6105H
%I (y + 12) ~ %I (y + 13)	2106H	6106H
%I (y + 14) ~ %I (y + 15)	2107H	N/A
...	210xH	N/A
%I (y + 30) ~ %I (y + 31)	210FH	N/A
%I (y + 32) ~ %I (y + 33)	N/A	N/A
...	N/A	N/A
%I (y + 40) ~ %I (y + 41)	user-defined address 1	user-defined address 1
...	user-defined address n	user-defined address n
%I (y + 54) ~ %I (y + 55)	user-defined address 8	user-defined address 8
%I (y + 56) ~ %I (y + 57)	N/A	N/A
%I (y + 58) ~ %I (y + 59)	N/A	N/A

**NOTE 1:** y is the start address of the host computer.

**NOTE 2:** The I means input, one motor drive address corresponds to two bytes, and one host computer address corresponds to one byte in order of low byte to high byte.

**NOTE 3:** User-defined address can define the address of the motor drive in the host computer. For example, Pr.04-50 = 16#0432 = 1074. The more addresses are defined, the longer the synchronization time between the motor drive and the host computer. You can define the user-defined address in the TIA portal. Refer to the periodic communication in the next chapter.

Refer to the MS300/MH300 user manual for more information on the 200xH, 210xH, 600xH, 610xH addresses mentioned in the table above.

### 5.3 Motor Drive Handling when Disconnection

If the PROFINET card is disconnected after the motor drive is connected to the PROFINET card, it will trigger Eccb. After the card has established real-time channel with the host computer, if it is found that it can no longer transmit real-time data normally, the motor drive will be notified and Ecto will be triggered by the motor drive. When the two fault codes above are triggered, the motor drive will stop.

This communication card accomplishes non-real-time data transfer through PROFINET's Record Data Object. During the transmission, the host computer sends a Write/Read request through the service and operation fields. The request should access the Record Data Object 0x4D2 defined by CMM-PN02, and specify the read/write action of the parameters of the motor drive through the different contents of the Data Block. After the request is sent, if there is no problem with the packet and the CMM-PN02 is not busy, the card will reply with a Write/Read Response to let the host computer know the packet has been received.

Field(s)	Description	Range	Type
Service	Request or Response service.	Request (0x00) Response (0x80)	UI8
Operation	Read or Write operation.	Write (0x08) Read (0x09)	UI8
Block Length	Length of the block.	0...0xFFFF	UI16
ARUUID	Identifier - time low - time mid - time high and version – clock – node	-	UI32 UI16 UI16 Qctet[2] Qctet[6]
API	Application Process Identifier	Device Access Point (0x000) PROFIdrive (0x3A00)	UI32
Slot	Slot of the Module Access Point (MAP/PAP)	0x01	UI16
Sub-slot	Sub-slot of the Module Access Point (MAP/PAP)	0x01	UI16
Padding	2 bytes		
Index	Index of the Record Data Object	0x0001–0x7FFF 0xB02E	UI16
Data length	Length of the data block	0...0xFFFFFFFF	UI32
Additional value 1 (response only)	Field for transferring additional data	-	UI16
Additional value 2 (response only)	Field for transferring additional data	-	UI16
Padding	24 bytes for request; 20 bytes for response.		
Data block	Used only with request and read response.		

When the host computer writes parameters, the content and flow of the data block should be as shown below:

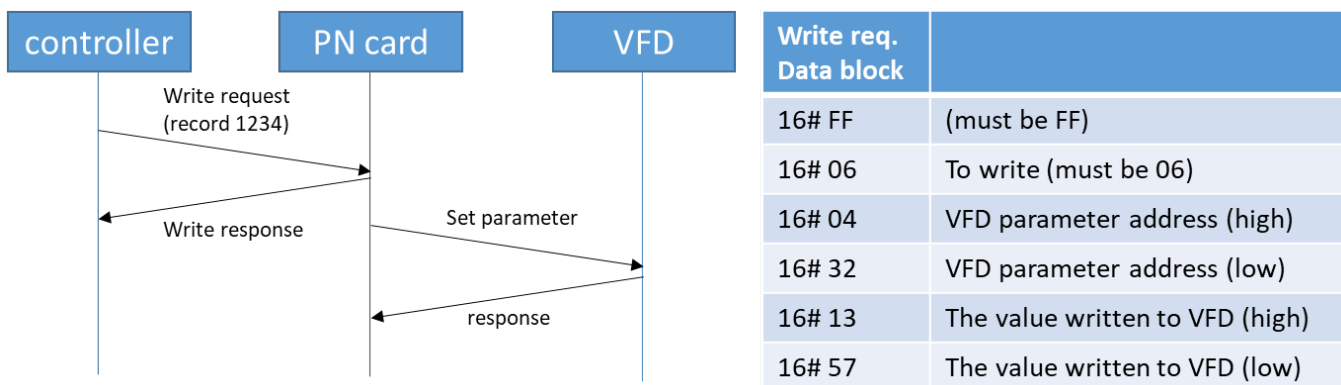

When the host computer needs to read the parameters, the data block content and the flow are as follows. It needs to use write request to notify CMM-PN02 to read the parameters of the motor drive, and then use read request to read the parameters. Note that after telling the motor drive to read the data, CMM-PN02 needs some time (more than 5ms) to receive the data from the motor drive, and if there is read/write during this time, the data will be incorrect.

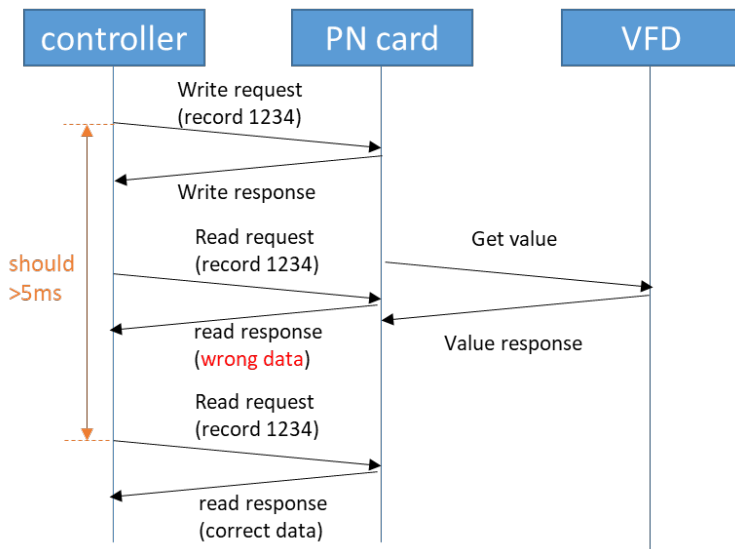

Write req. Data block	
16# FF	(must be FF)
16# 03	To read(must be 03)
16# 04	VFD parameter address (high)
16# 32	VFD parameter address (low)

Read resp. Data block	
16# AB	VFD parameter value (high)
16# CD	VFD parameter value (low)

## 6 Connection Configuration to Host Controller

This section introduces how Siemens STEP 7 and TIA PORTAL PLC integral software, as well as Siemens PLC S7-300 and S7-1500 use PROFINET to connect MS300/MH300 drives. The connection configuration shows as the figure below. Siemens PLC connects CMM-PN02 communication card of MS300/MH300 drive through the EtherNet.

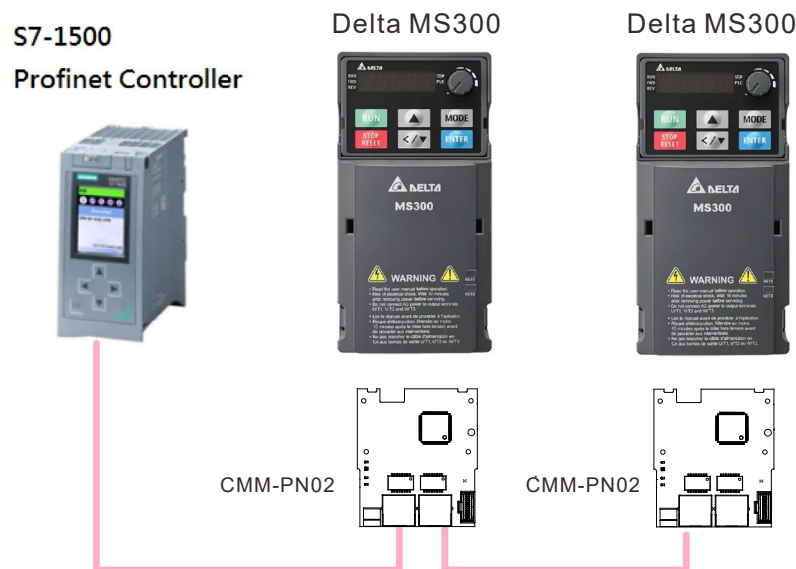

### 6.1 Basic Configuration

#### ■ The Settings for Communication

1. Start your PC and set IP address configuration as static IP address. It is recommended to set the address to 192.168.xxx.xxx in the red box as the figure below shows.

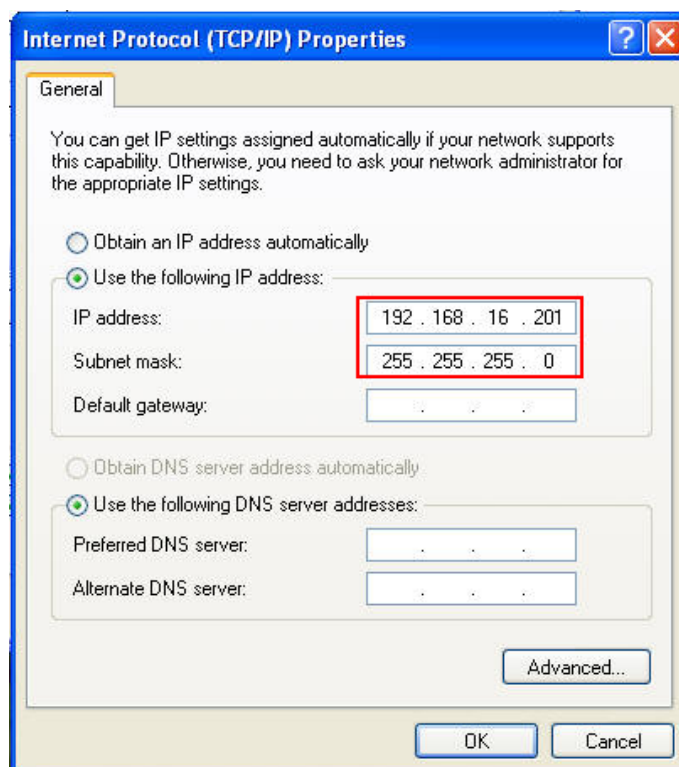

2. Use Siemens STEP 7 to look up the host controller's IP address. In the screen of HW Config, perform the function under **PLC→EtherNet→Edit Ethernet Node** as the figure below shows.

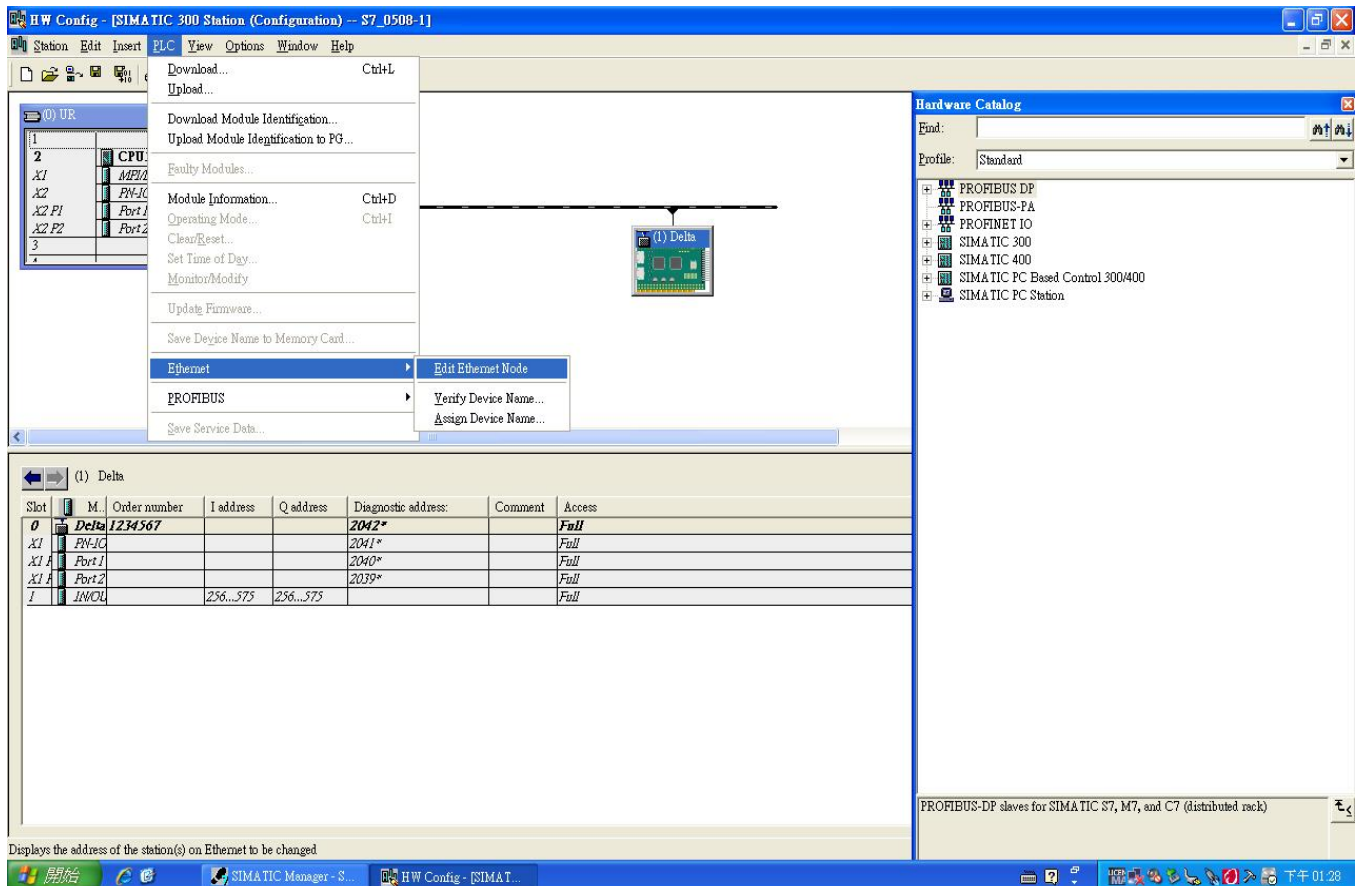

Click **Browse** button to search the available device on the Internet.

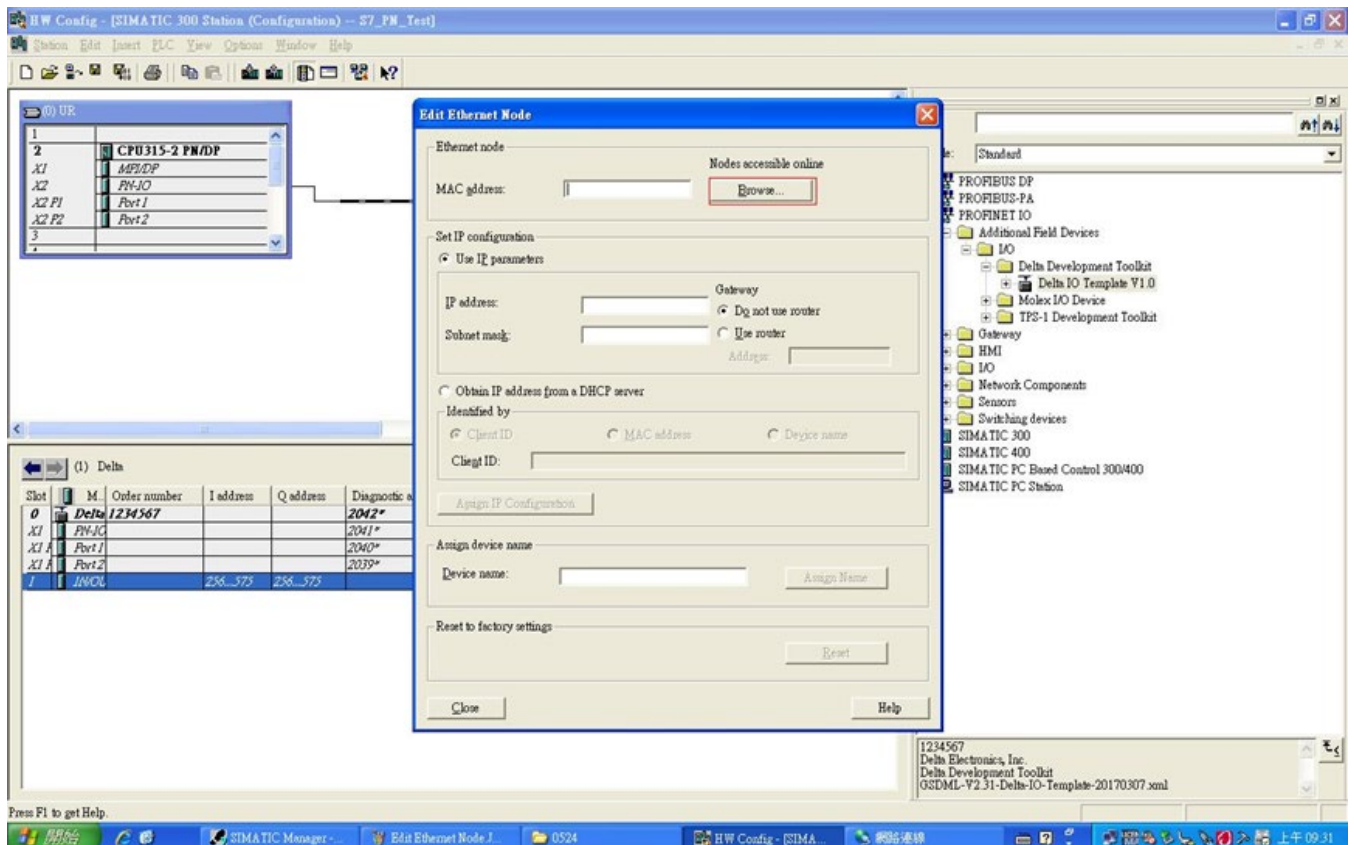



When it finishes searching, a screen displays as shown in the figure below. The IP address displays 192.168.16.26.

If the IP address of your computer is set as a different one, it is recommended to reset your PC's IP address to make it consistent with PLC's domain.

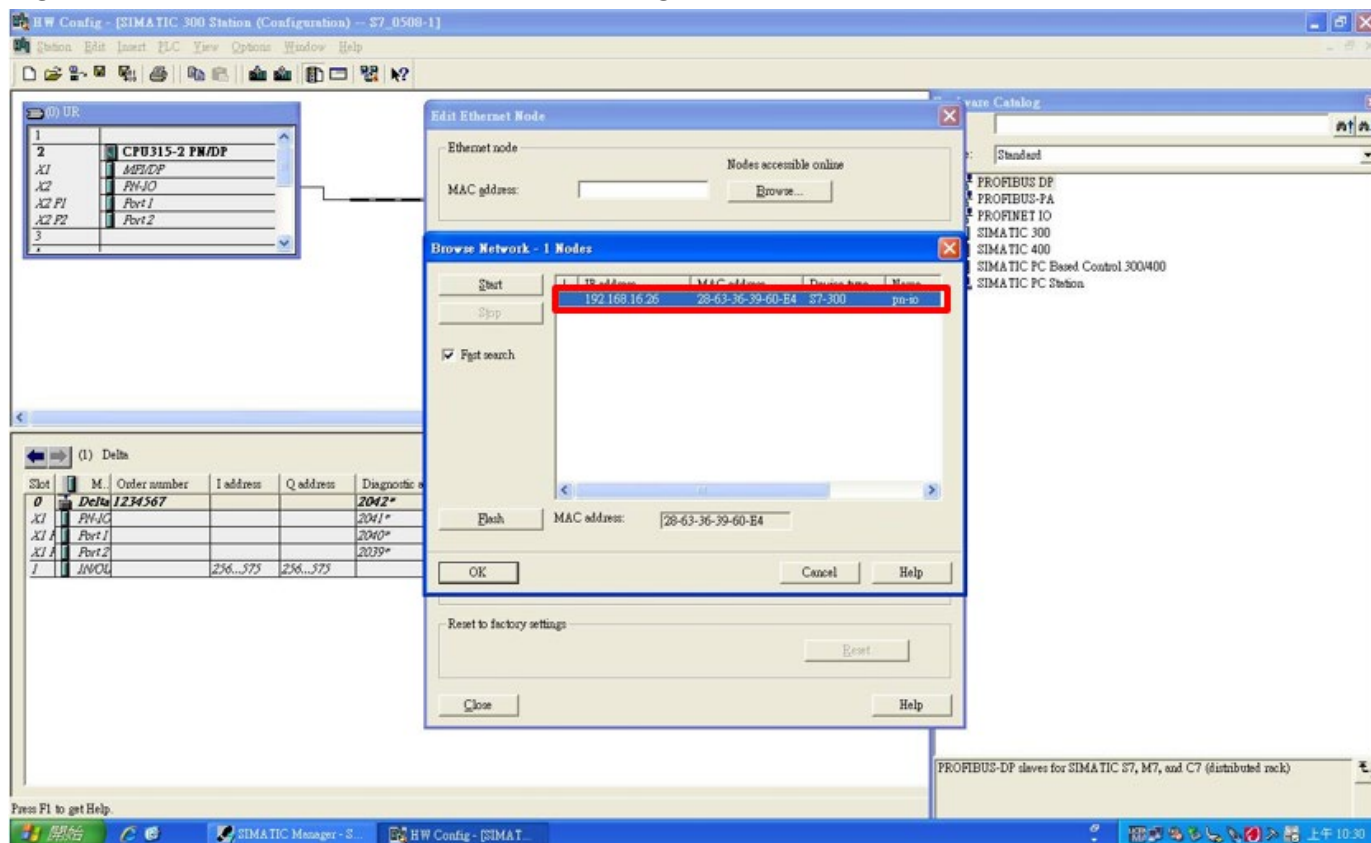

**NOTE:** If the IP address of your computer is different from PLC's domain, you are unable to download the program to PLC.

- Using Siemens TIA PORTAL to search PLC IP address. Start TIA PORTAL, select **Online & Diagnostics**, and then click **Project view**.

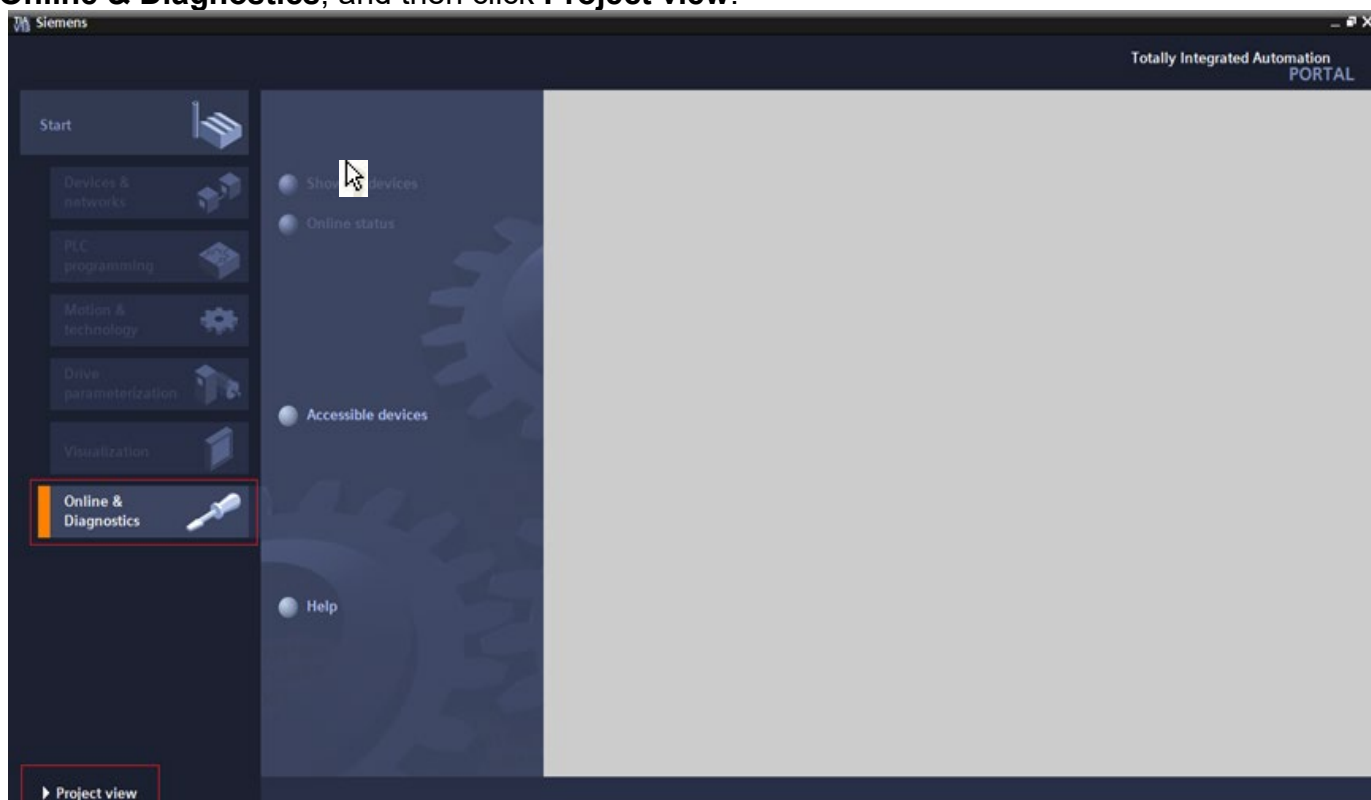

Select **Online access**, choose your PC network interface card, and then click **Update accessible devices** continuously to search PLC.

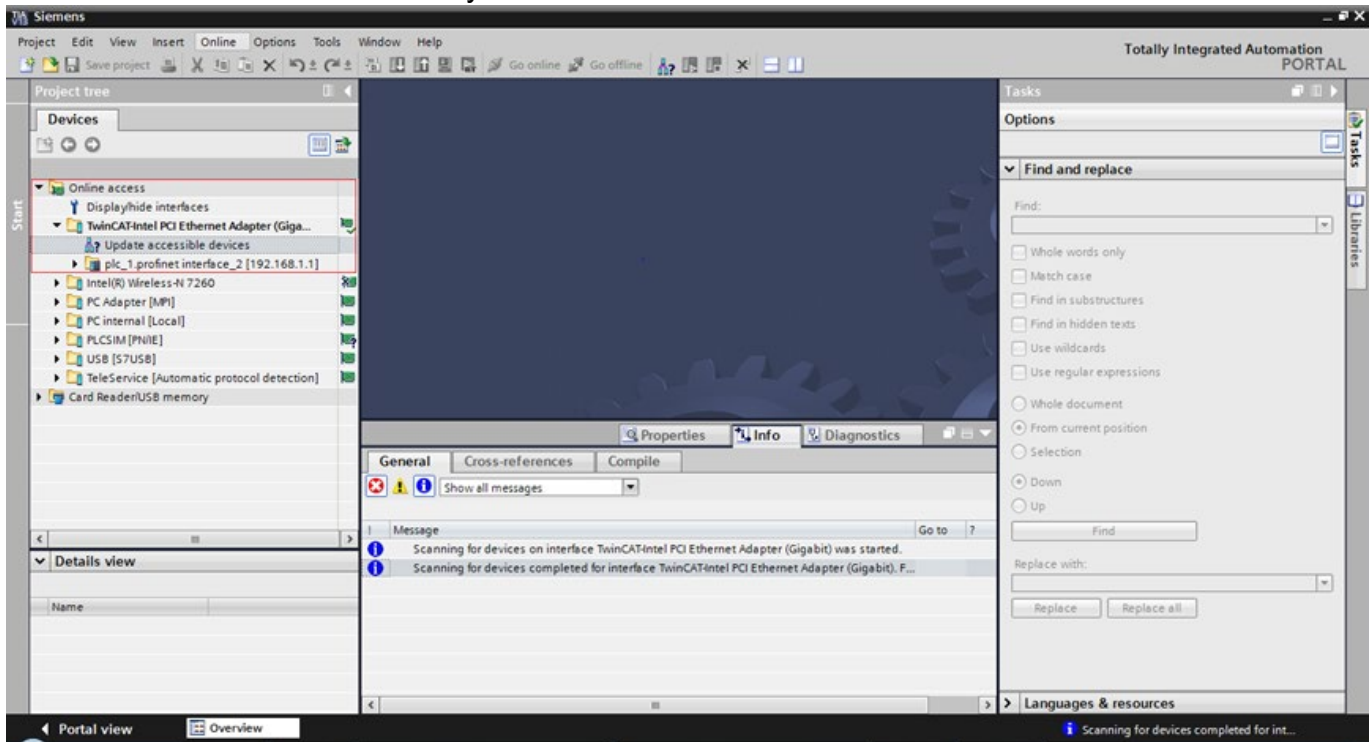

**NOTE:** When you start TIA PORTAL, do not enable wireless network because it may lead to TIA PORTAL's false detection. If it happens (physical interface card cannot be found), close the wireless network connection first and then restart TIA PORTAL.

4. Modify the name of CMM-PN02. The steps are the same as those for setting PLC address. For STEP7, set the drive name as the figure below shows.

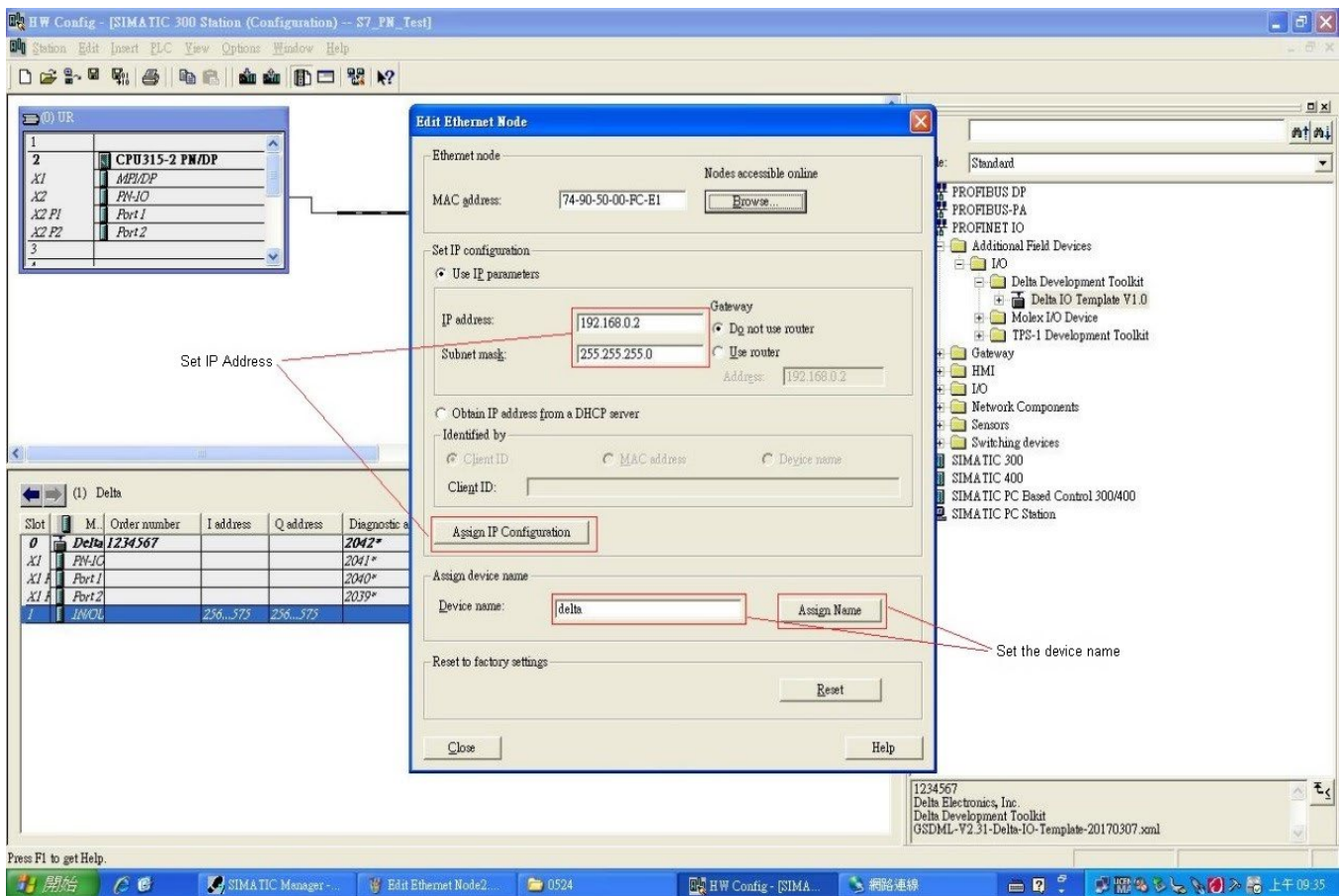

For TIA PORTAL, set the device name of the host controller or CMM-PN02 as the figure below shows.

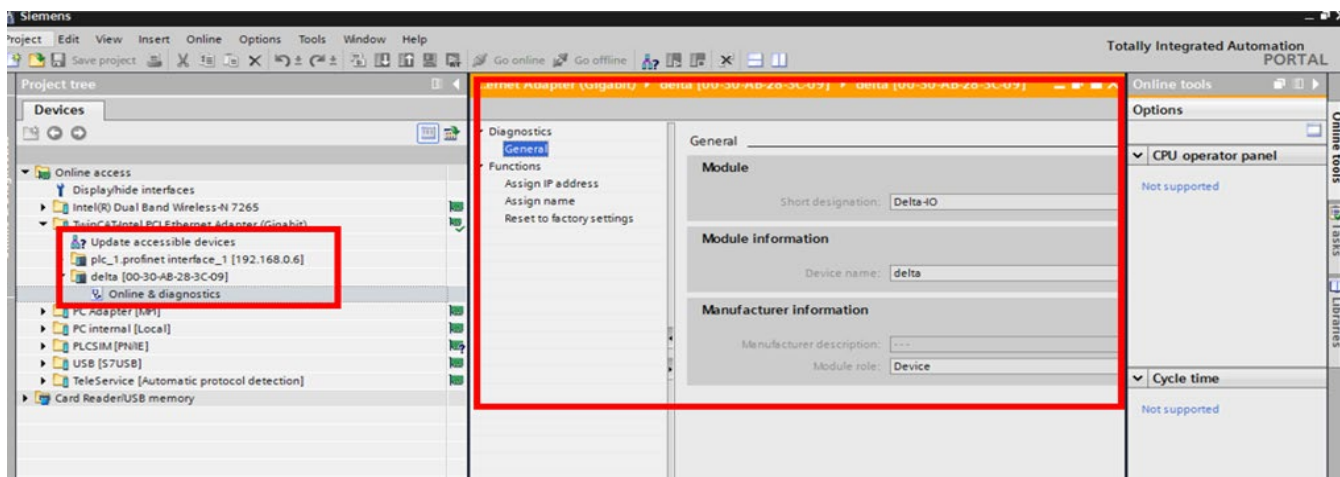
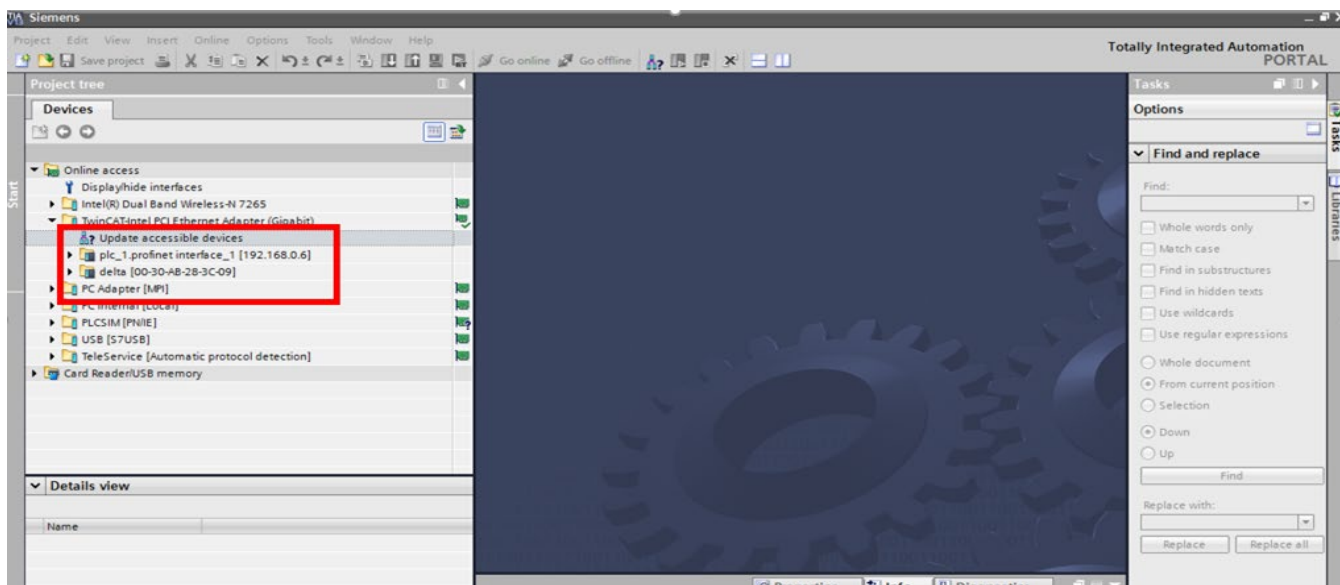
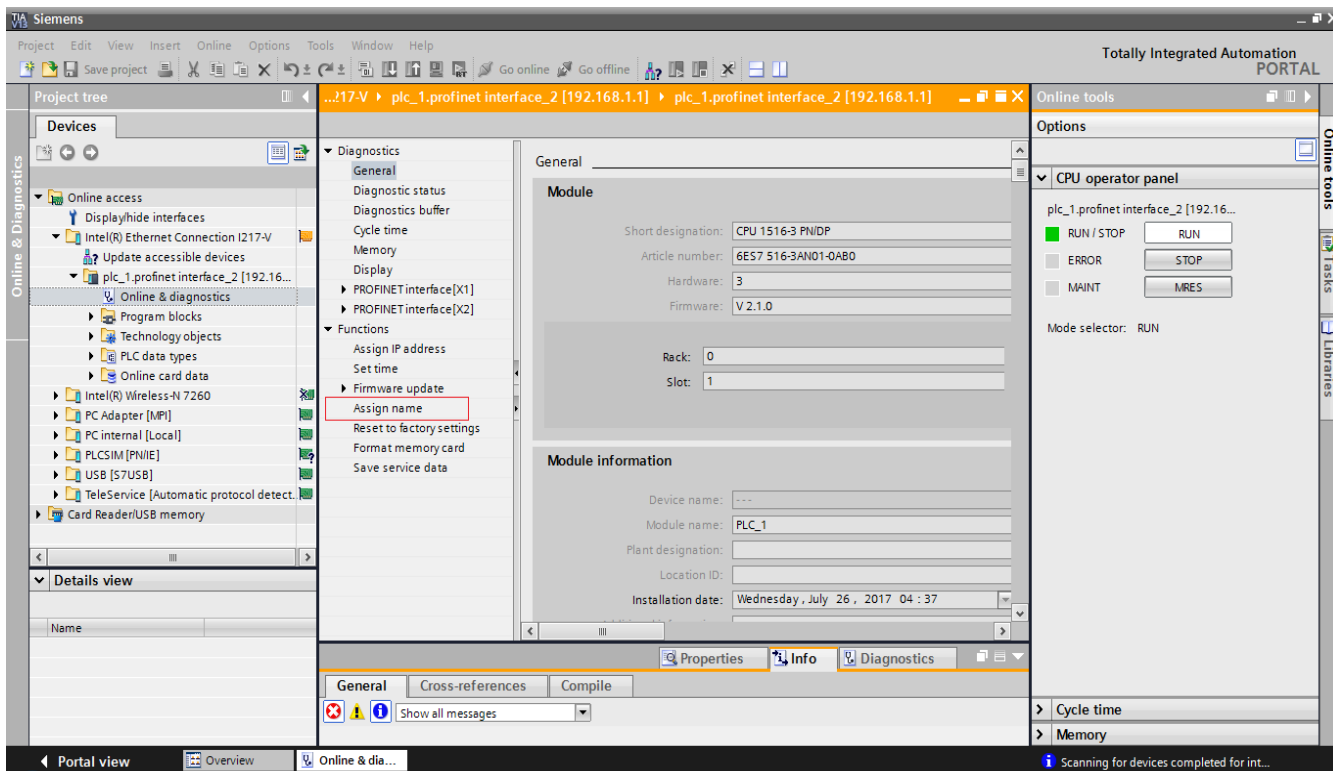

## 6.2 Speed Mode DEMO (S7-300 + STEP 7)

- Using Siemens STEP 7 to finish PLC setting, connection test, and speed mode DEMO

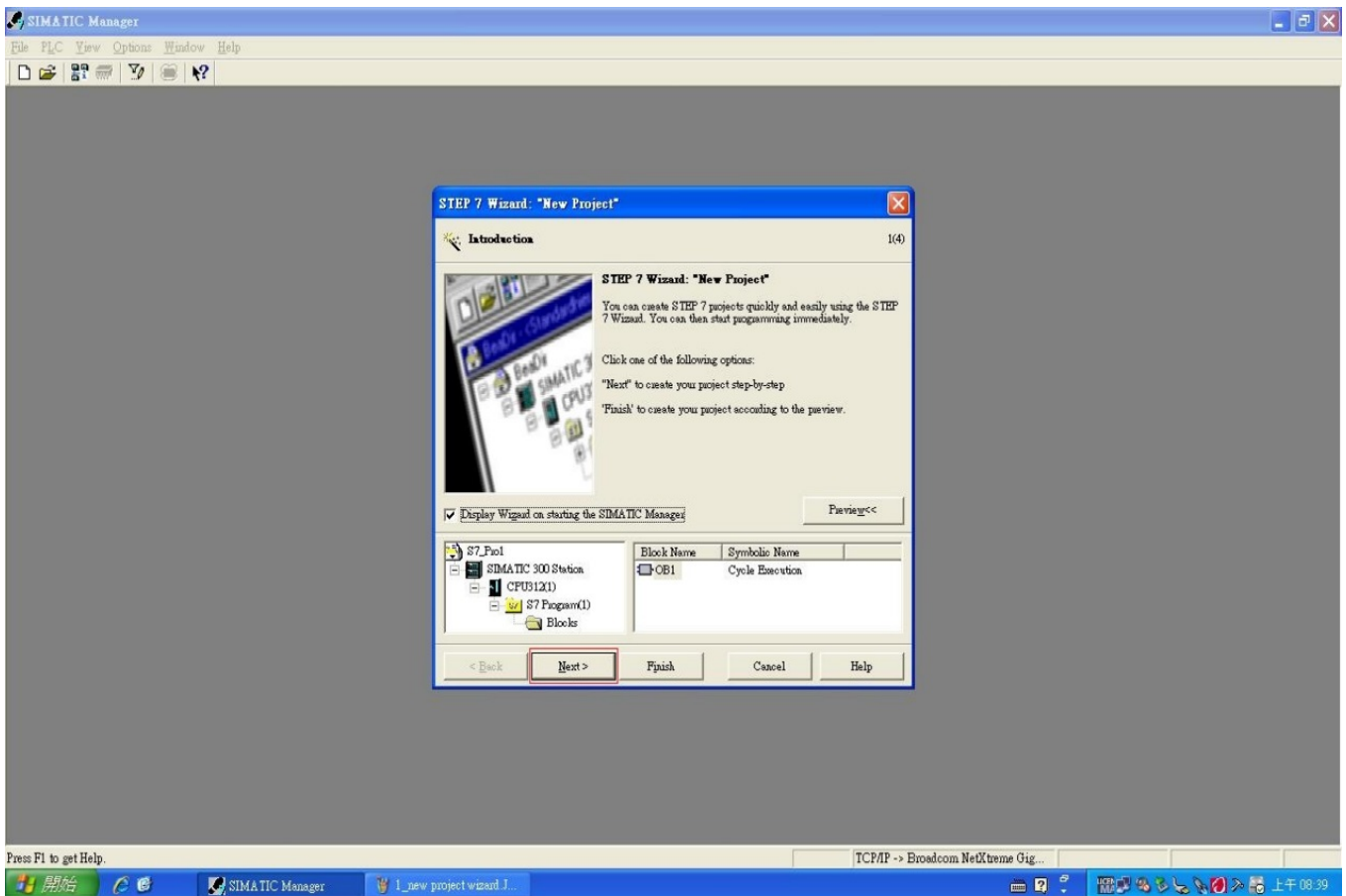
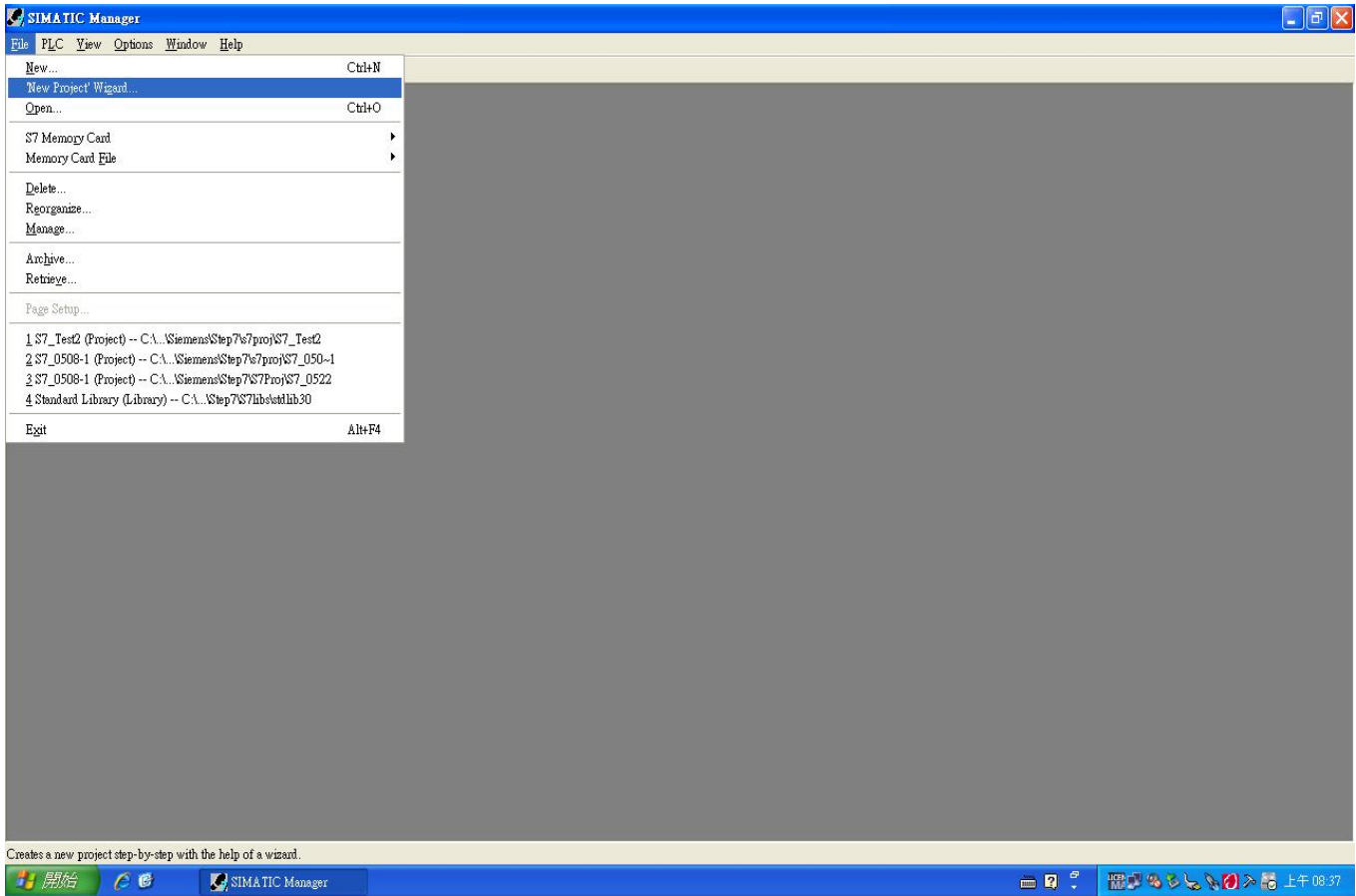

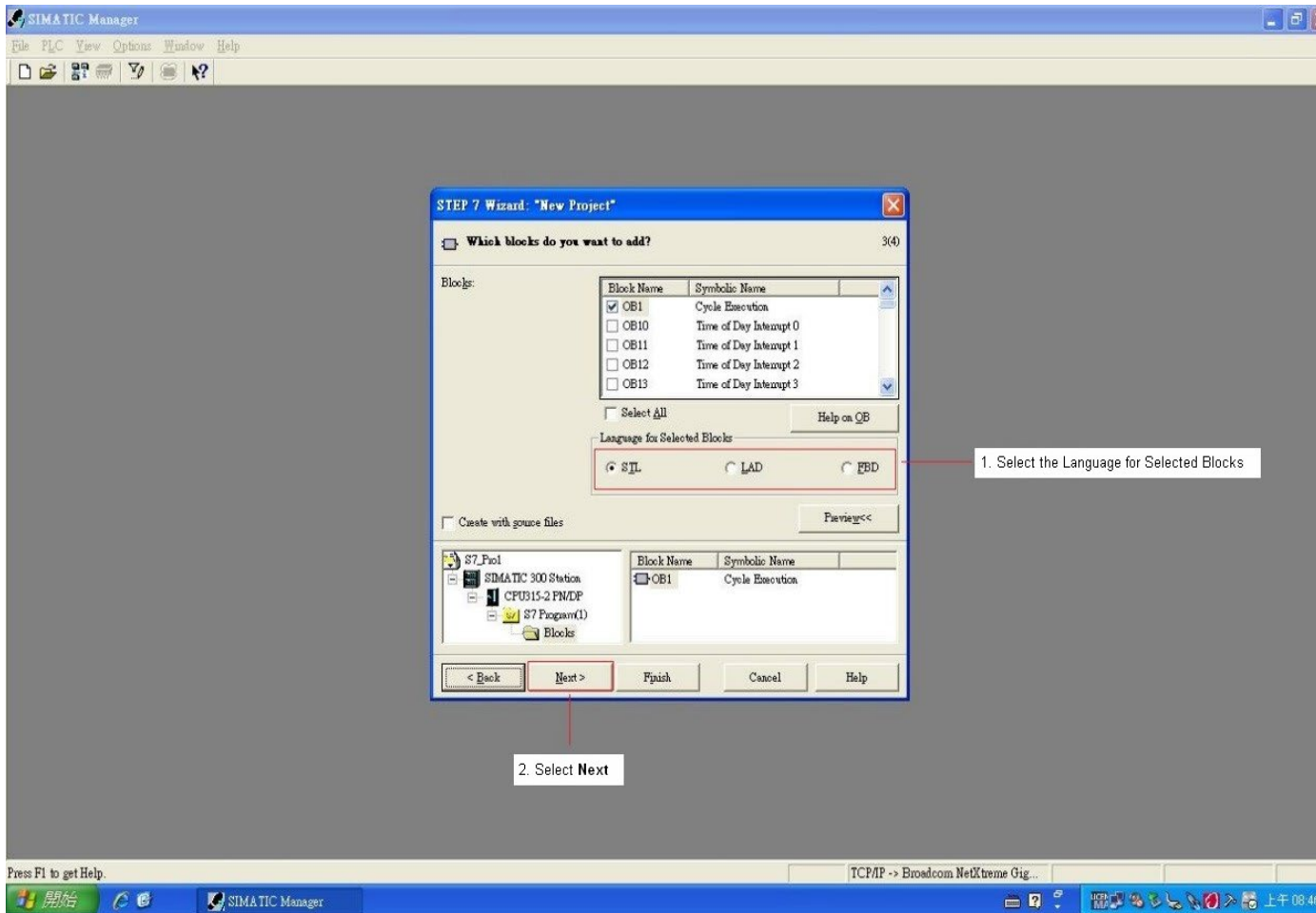
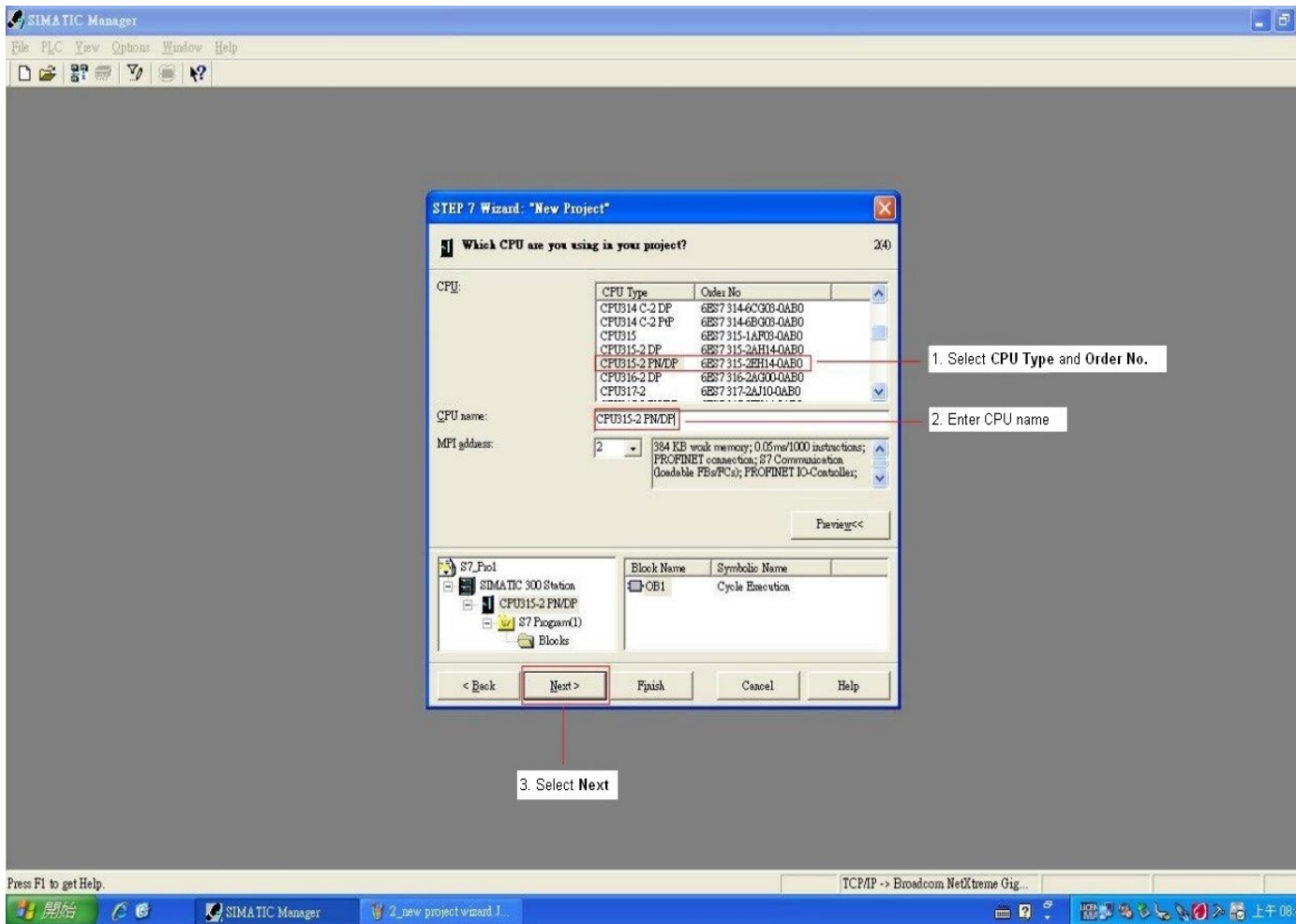

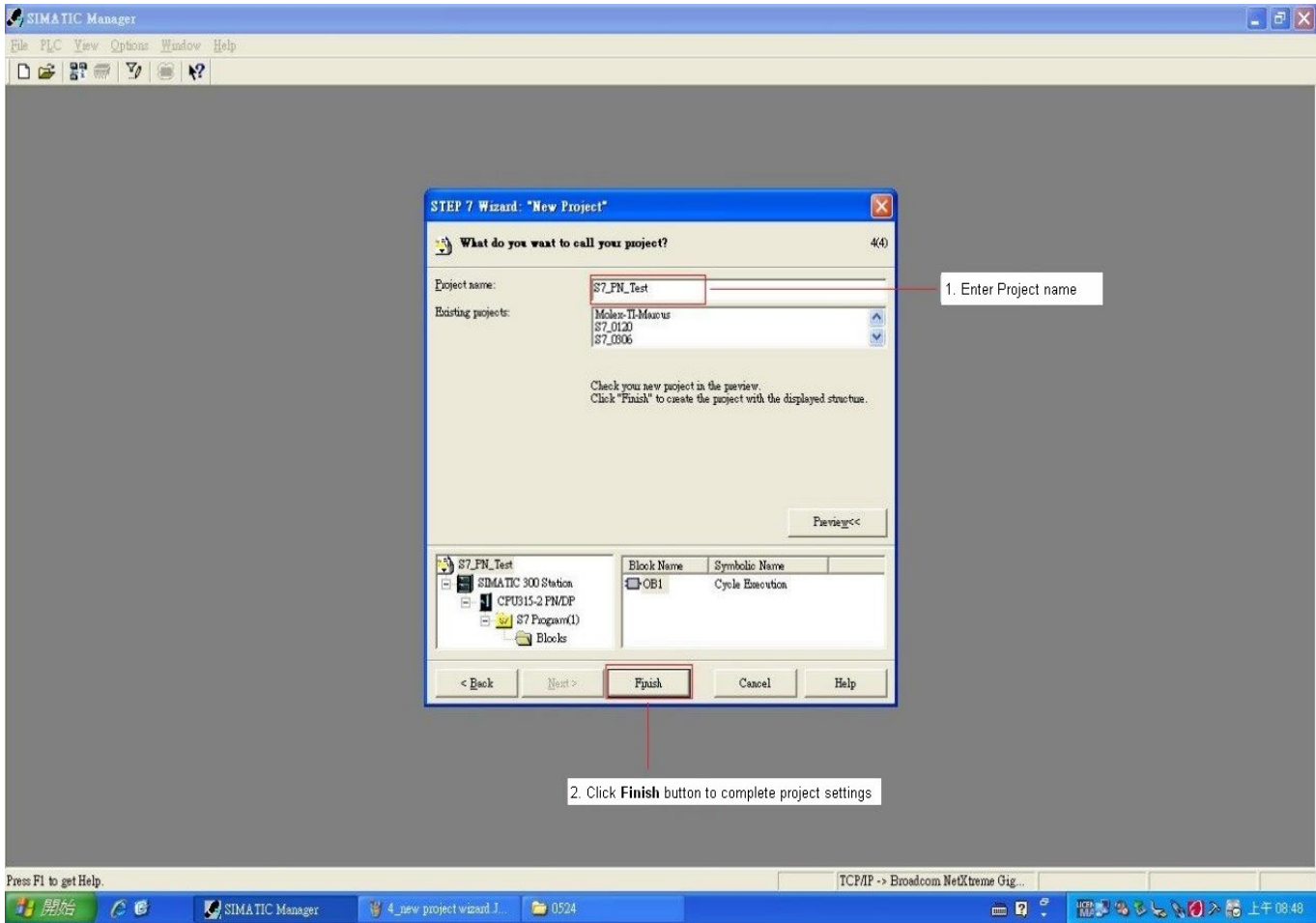

In HW Config, install GSDML and set up PROFINET framework as the figure below shows.

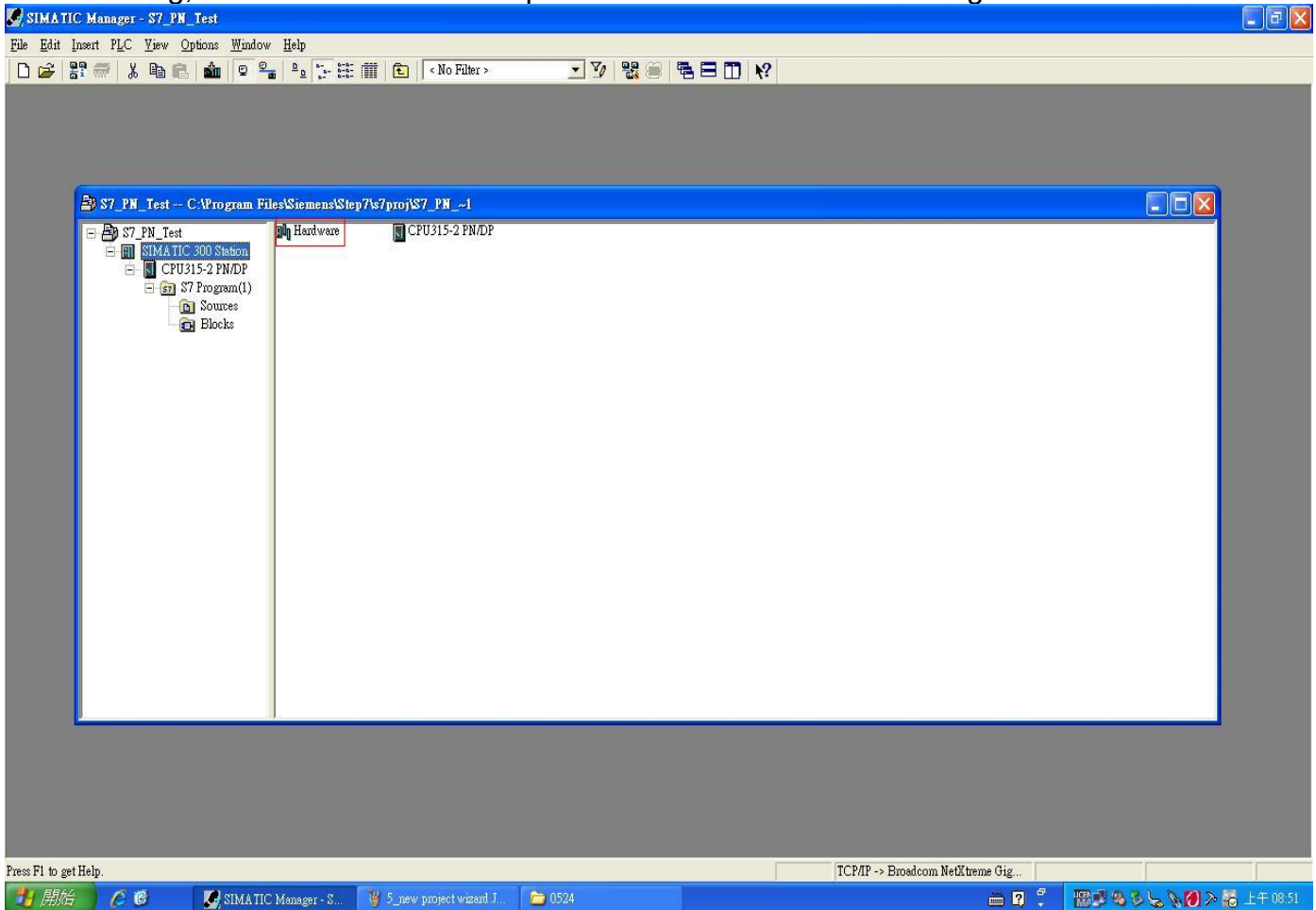

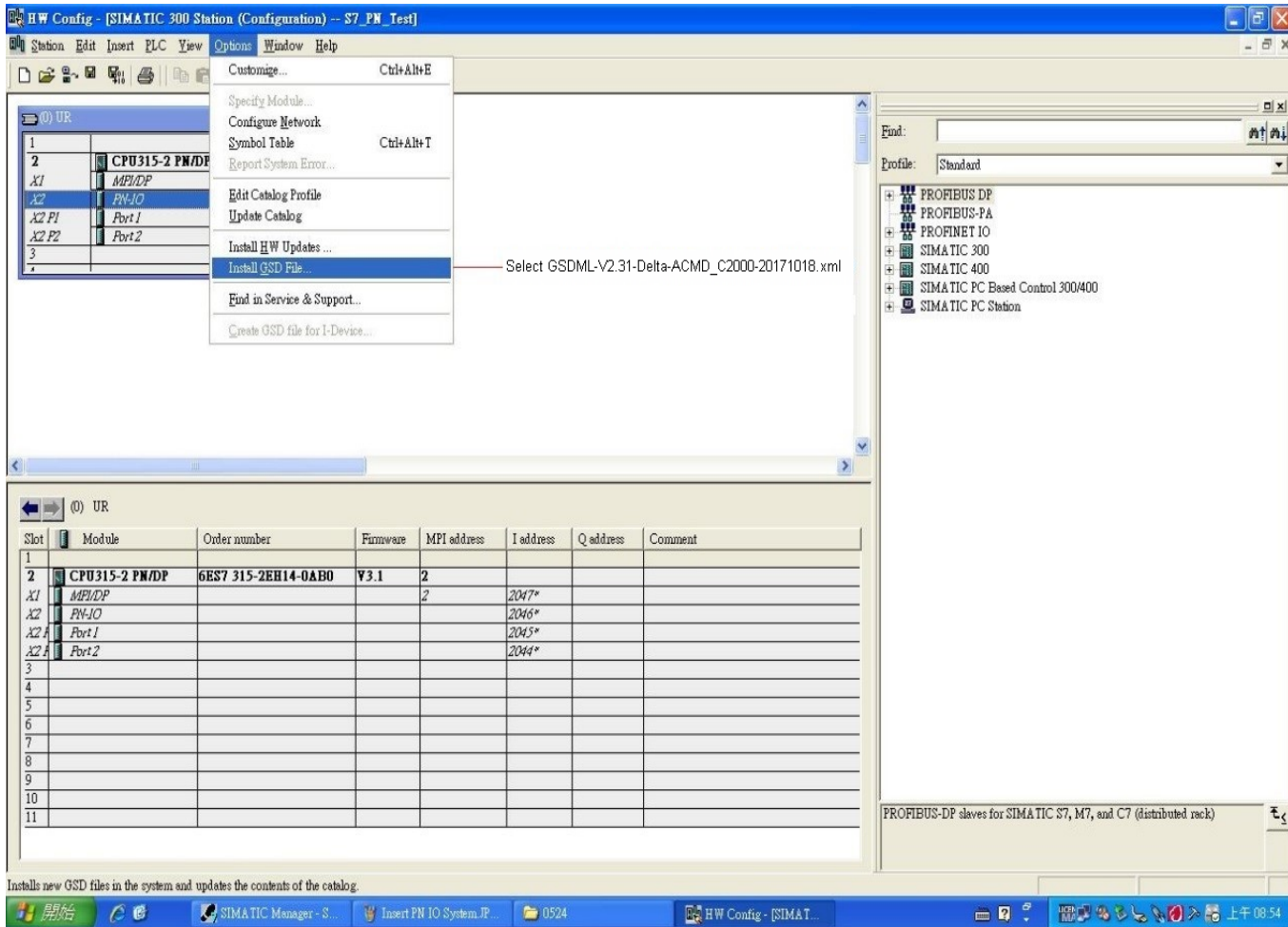

When the installation of GSDML is completed, the right side in the figure below displays.

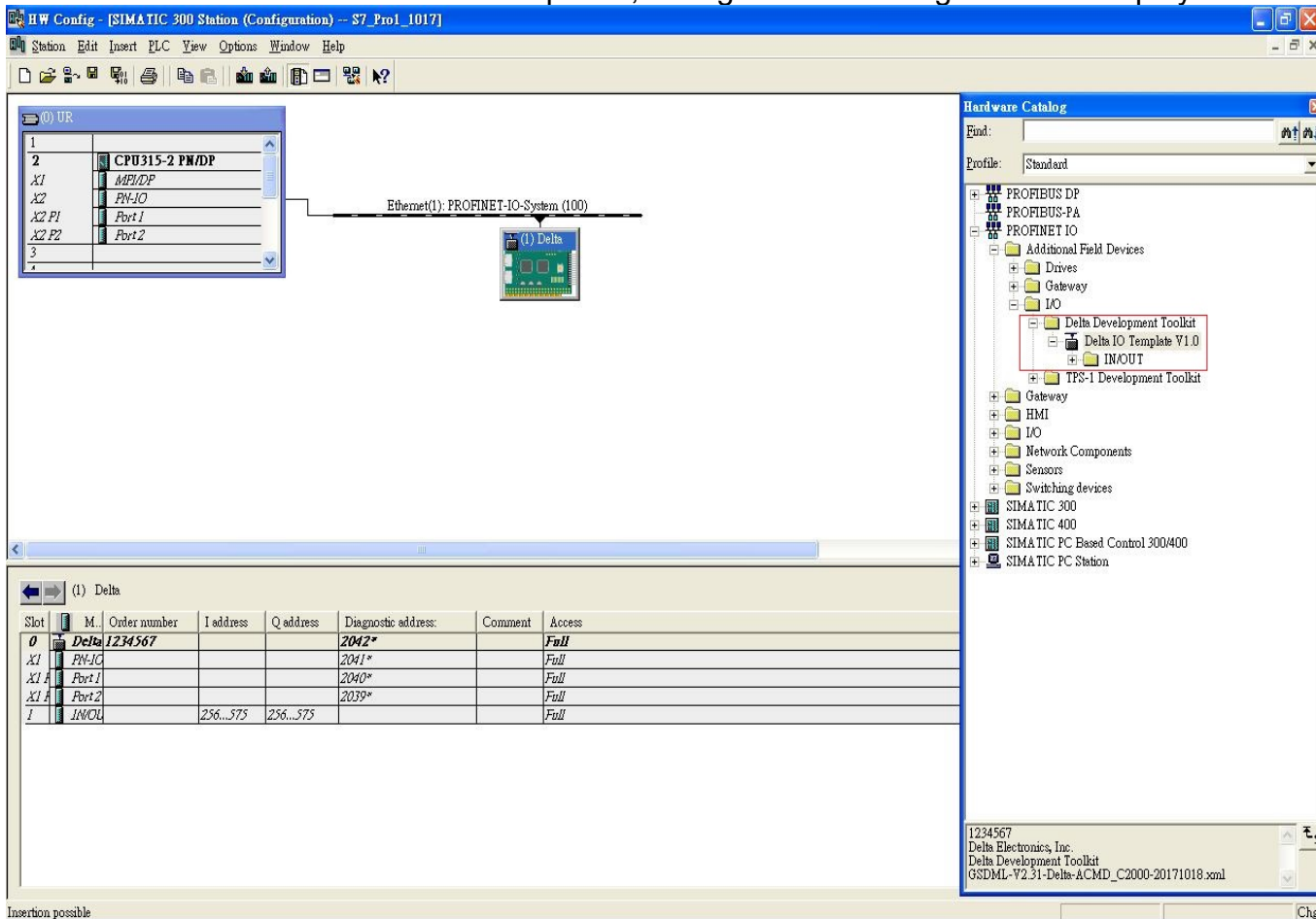

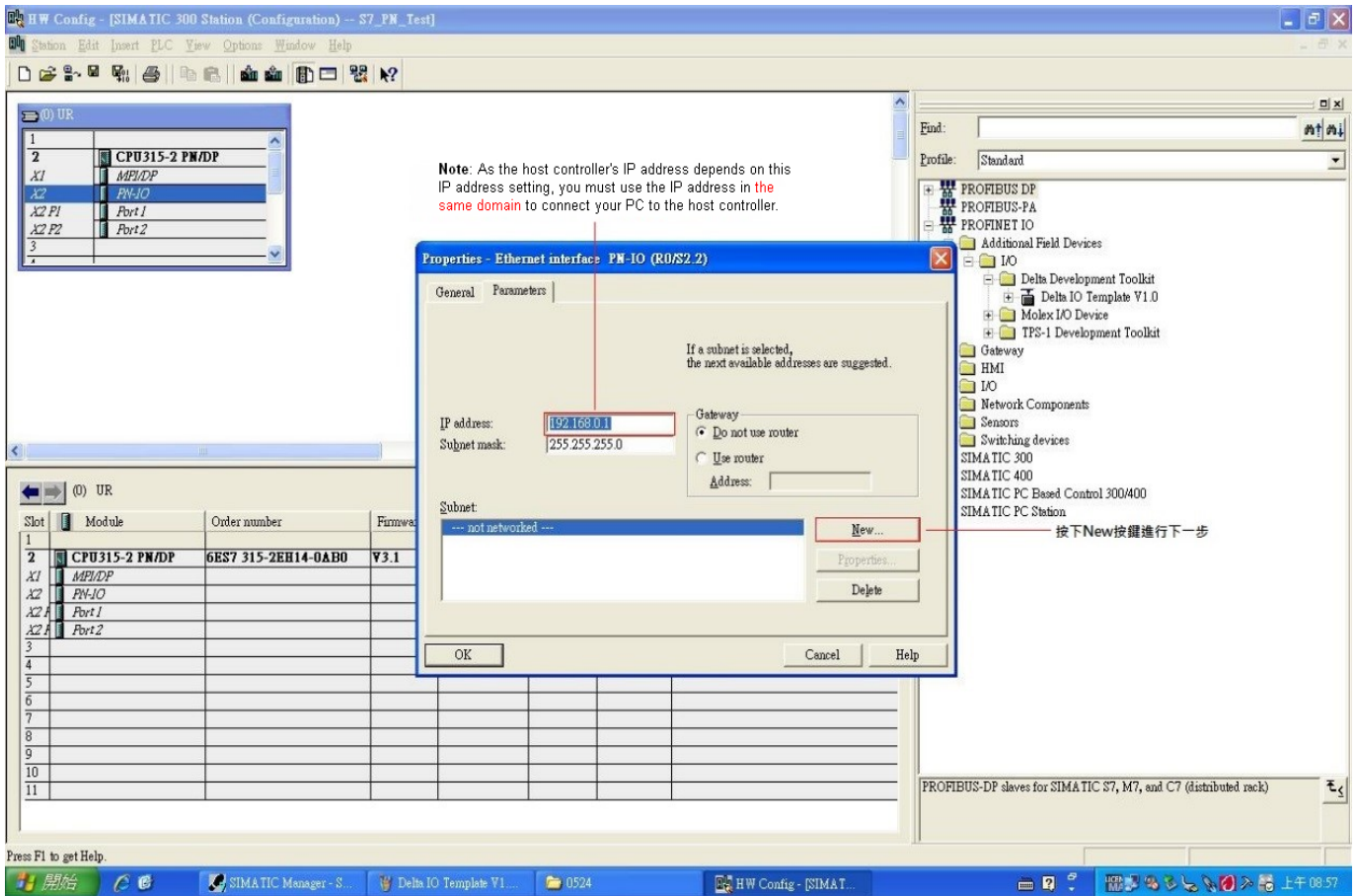
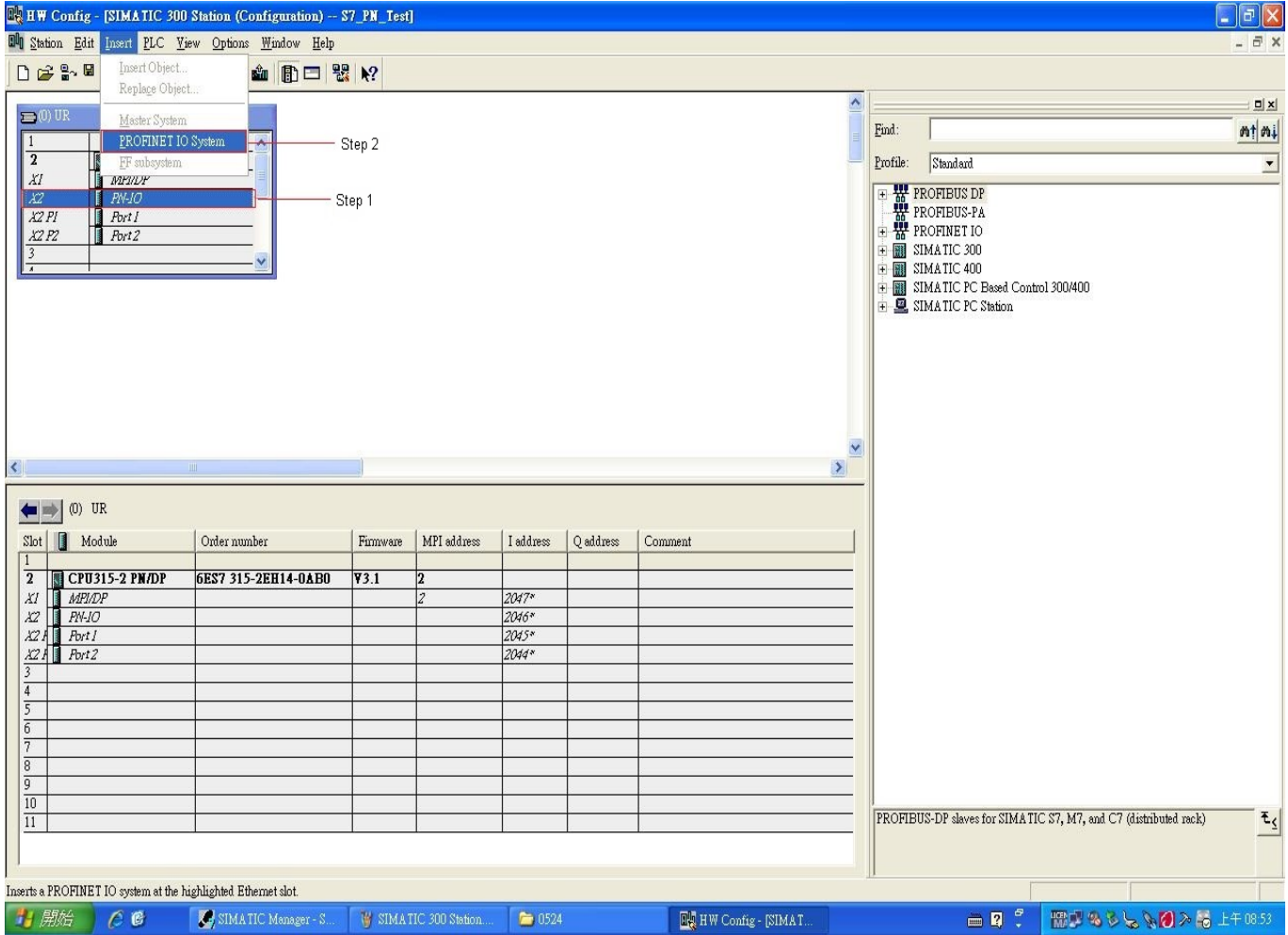



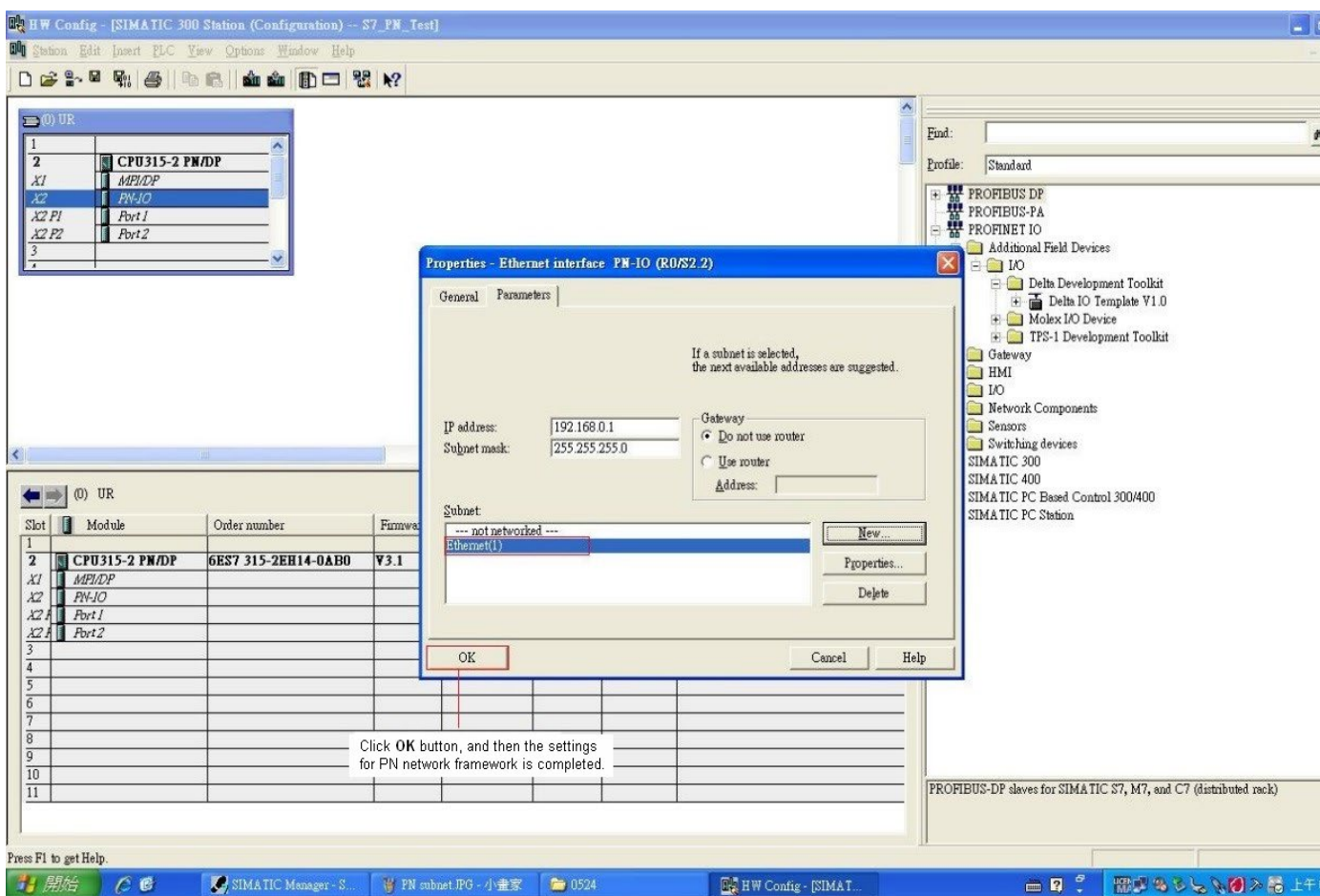
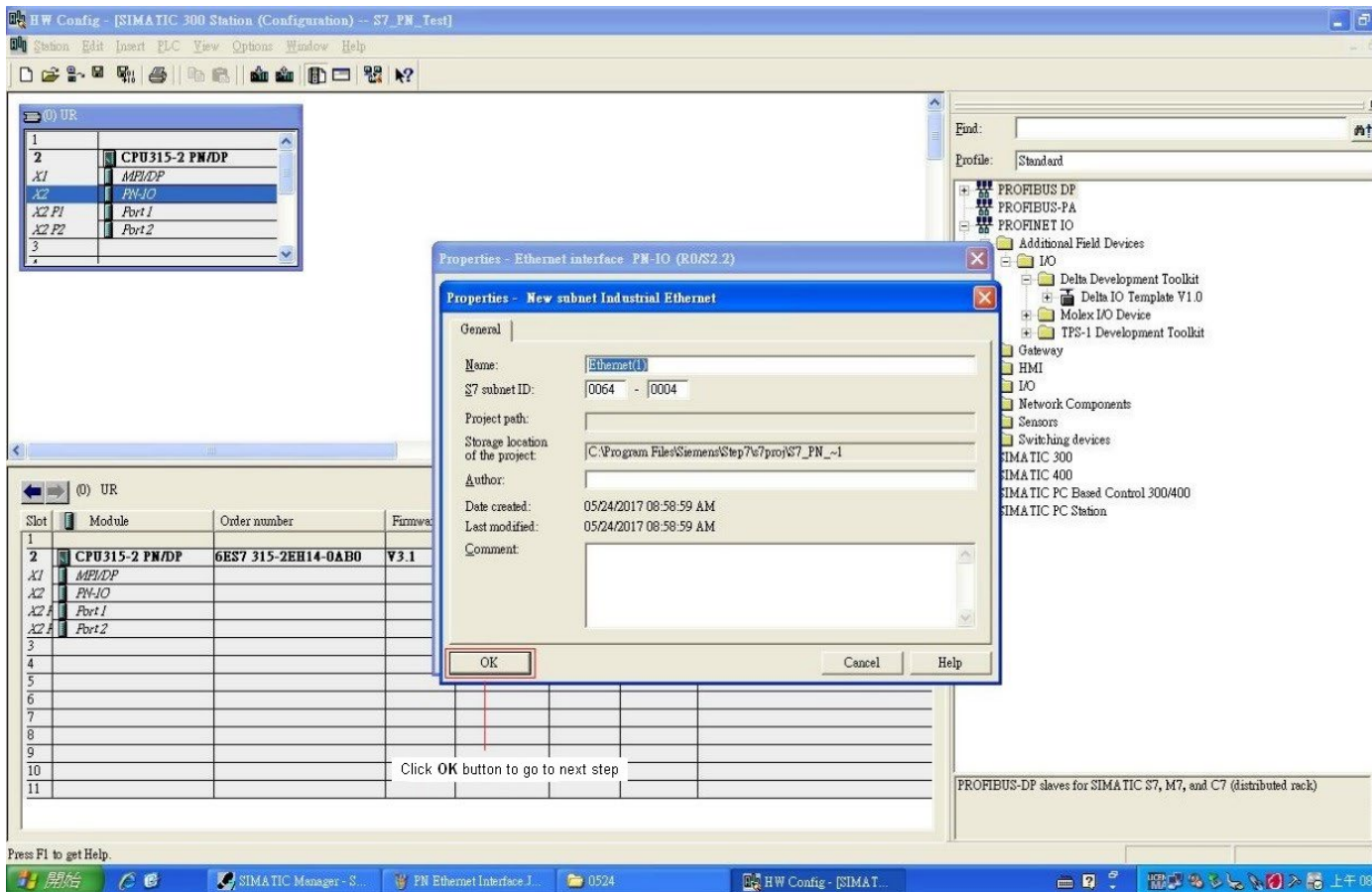

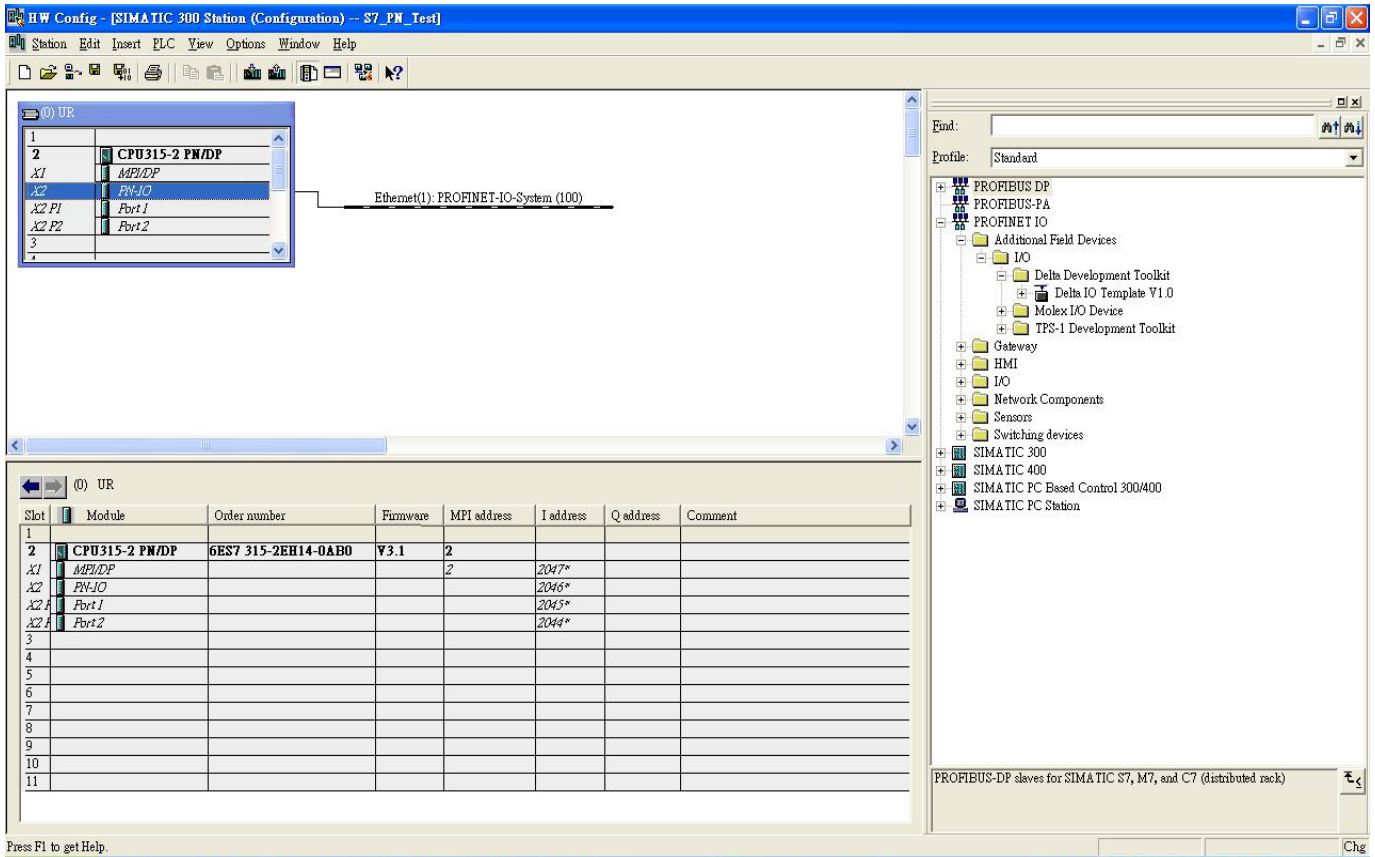

Right-click the mouse and drag Delta IO Template V1.0 to PROFINET-IO-System until the plus sign (+) appears. When it is completed, the figure below shows.

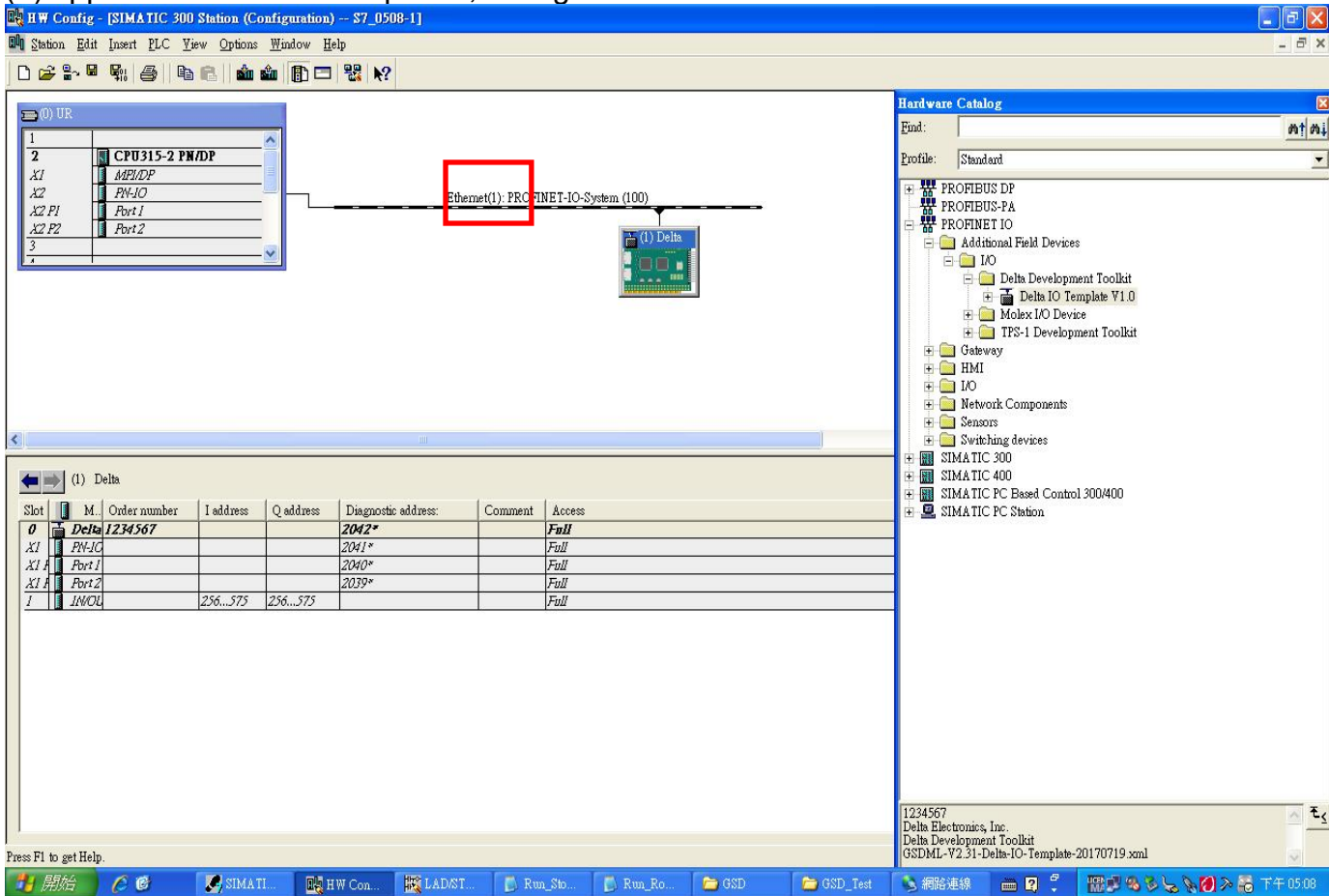

**NOTE:** The host controller in PROFINET communication is identified by the name in communication cards. Therefore, if it does not match to the settings of the host controller, the communication fails.

Then, you can use **Compile** and **Download** icon to compile and download programs.

 : Compile

 : Download

When the program finishes downloading, you have to switch S7-300 to STOP Mode to be back at RUN Mode. If there is no problem with CMM-PN02 communication, the status of LED indicators for S7-300 shows as the figure below.



## ■ Testing the Start and Stop of the Drive

To verify if the host controller can control the drive through CMM-PN02, you must write the PLC program.

For STEP 7, the program-editing screen below illustrates an example of writing a program by using 60xx message format.

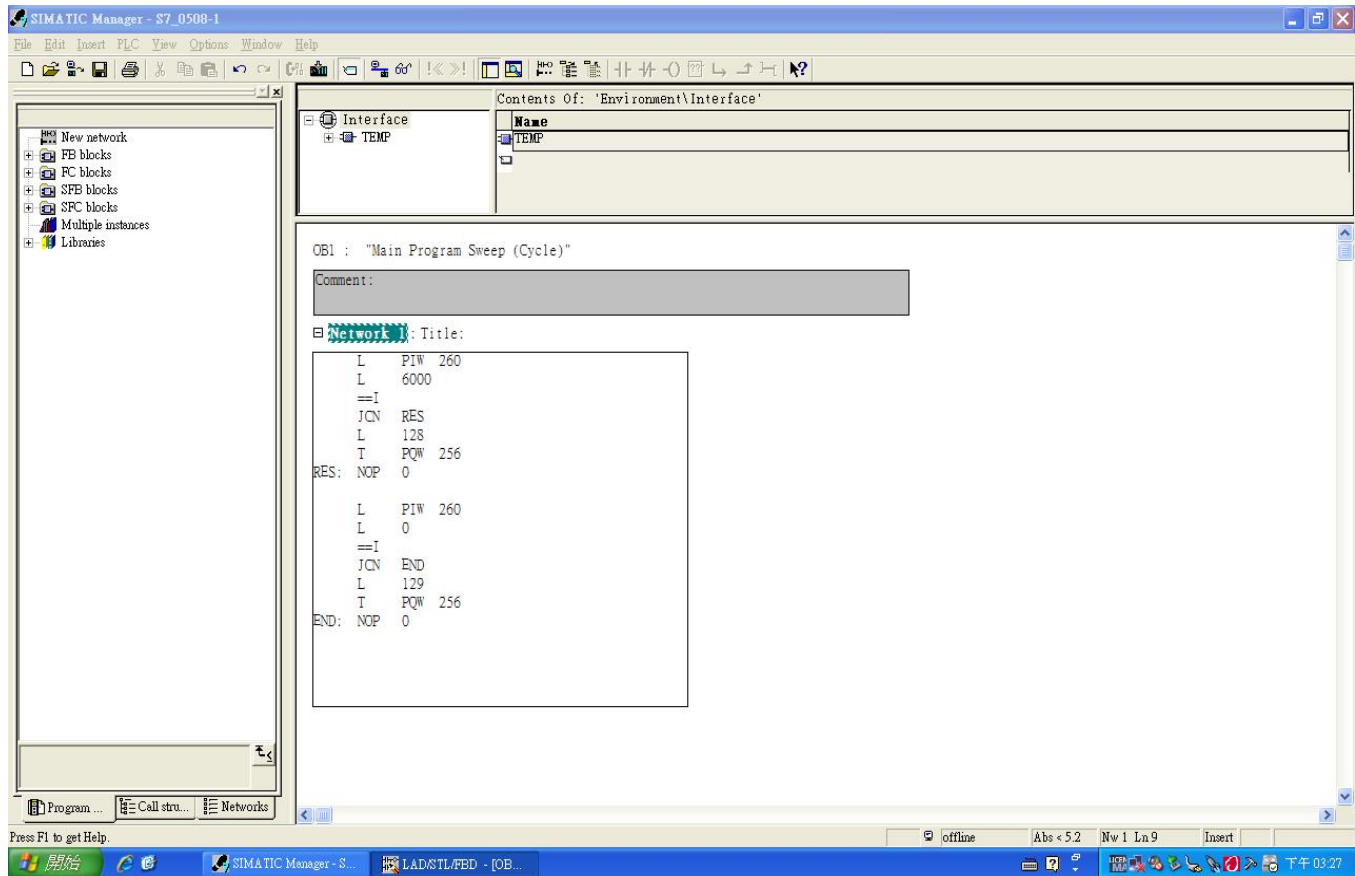

1. PIW260 means 6102H (actual output frequency).
2. PQQW256 means 6000H (control word).
3. The writing of the program explains as follows.  
OB1 Program (Main Loop) is explained as follows:
  - a. Judging if PIW260 (6102H) equals to 6000. If YES, PQQW256 (6000H) equals to 128 (0x80), which means the drive stops running; if NO, go to RES label;
  - b. Judging if PIW260 (6102H) equals to 0. If YES, PQQW256 (6000H) equals to 129 (0x81); if NO, go to END label;

Therefore, the drive performs continuous actions of running until stop, and then starts running again.

Below is the STEP 7 program-editing screen and an example of writing a program by using 20xx message format.

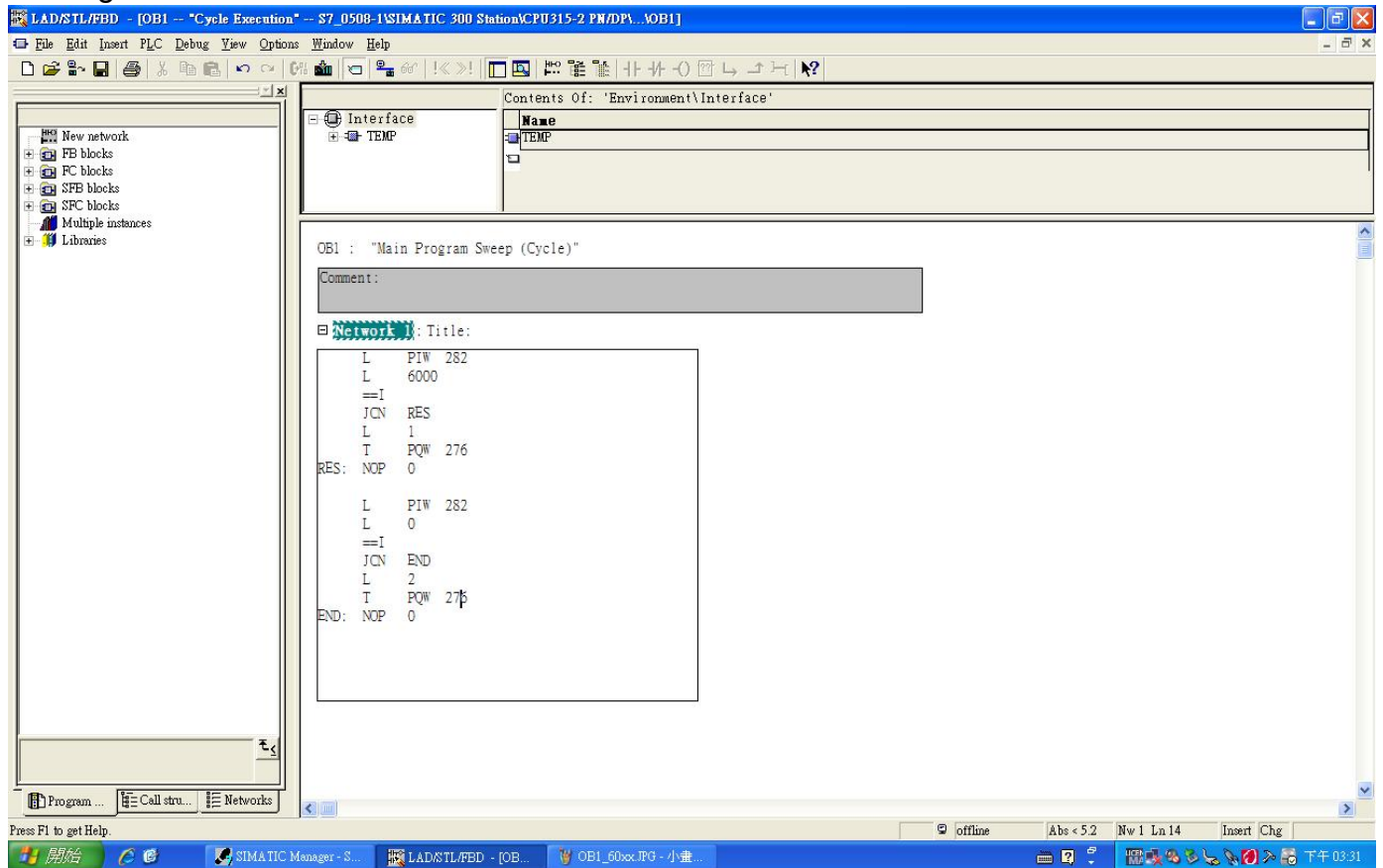

1. PIW282 means 2103H (output frequency).
2. PQW276 means 2000H (control word).
3. The writing of the program explains as follows.  
OB1 Program (Main Loop) is explained as follows:
  - a. Judging if PIW282 (2103H) equals to 6000. If YES, PQW276 (2000H) equals to 1, which means the drive stops running; if NO, go to RES label;
  - b. Judging if PIW282 (2103H) equals to 0. If YES, PQW276 (2000H) equals to 2, which means the drive starts running; if NO, go to END label;

Therefore, the drive performs continuous actions of running until stop, and then starts running again.

## 6.3 Speed Mode DEMO (S7-1500 + TIA PORTAL)

Create Project.

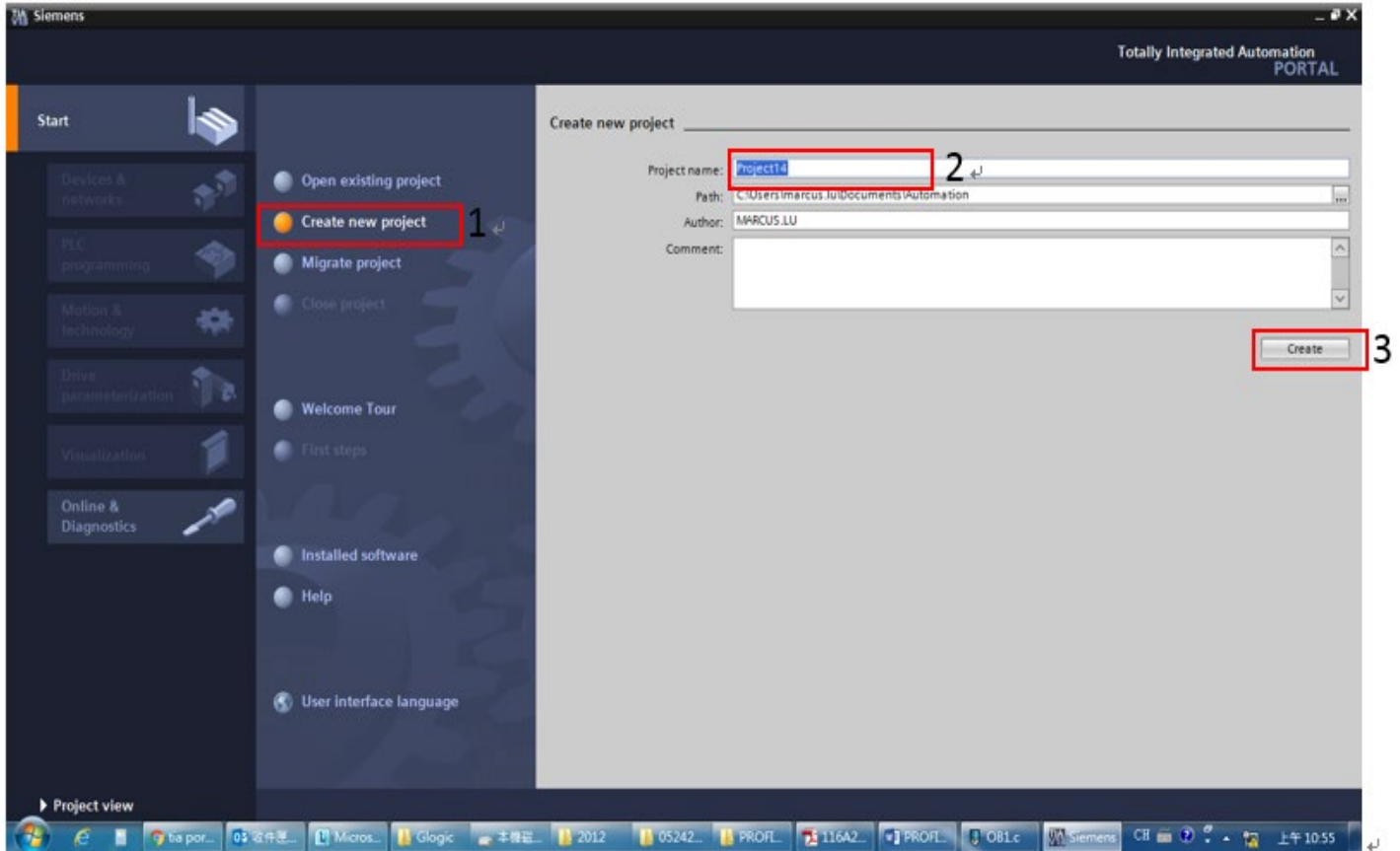

Select Project view.

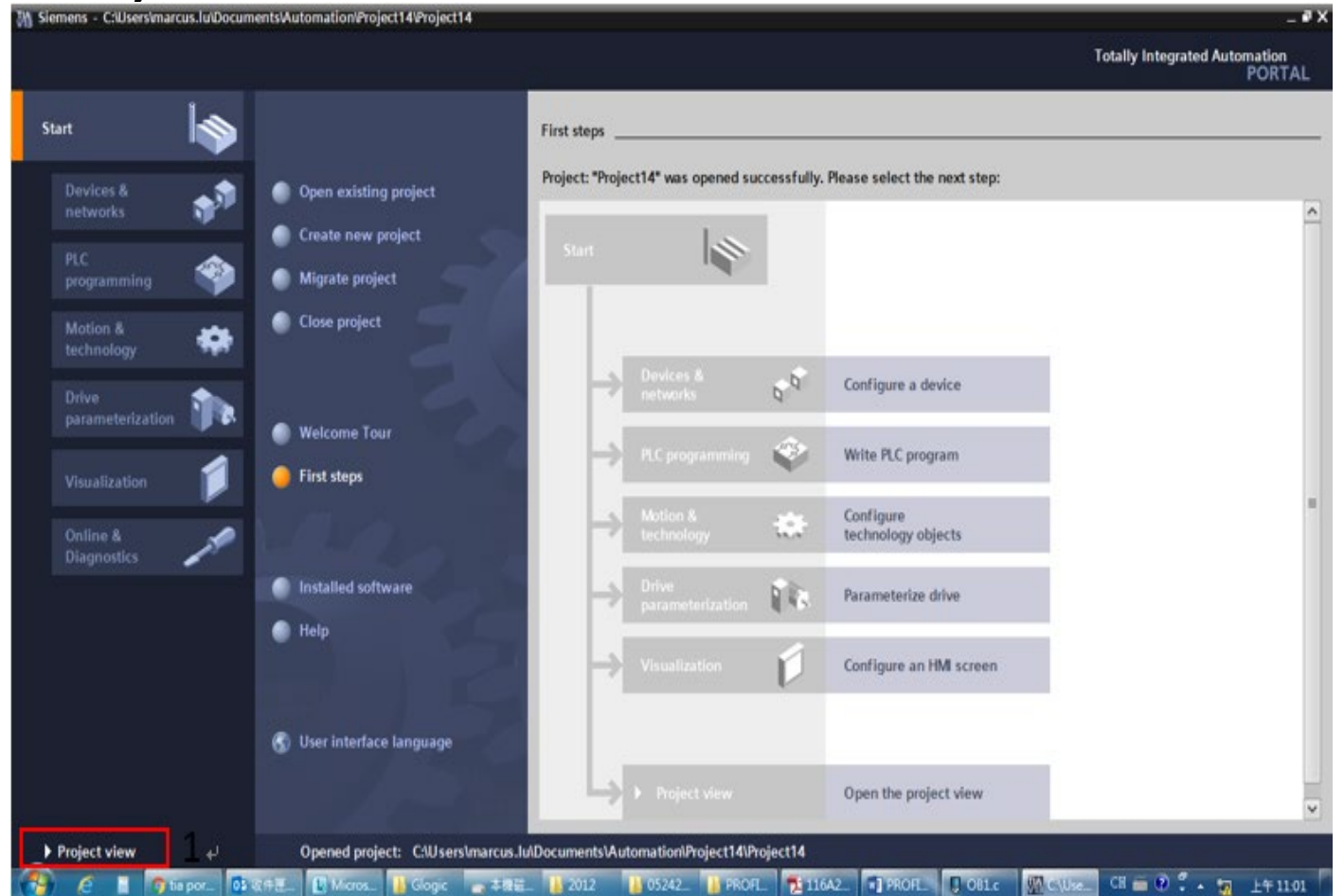

## Install GSD file.

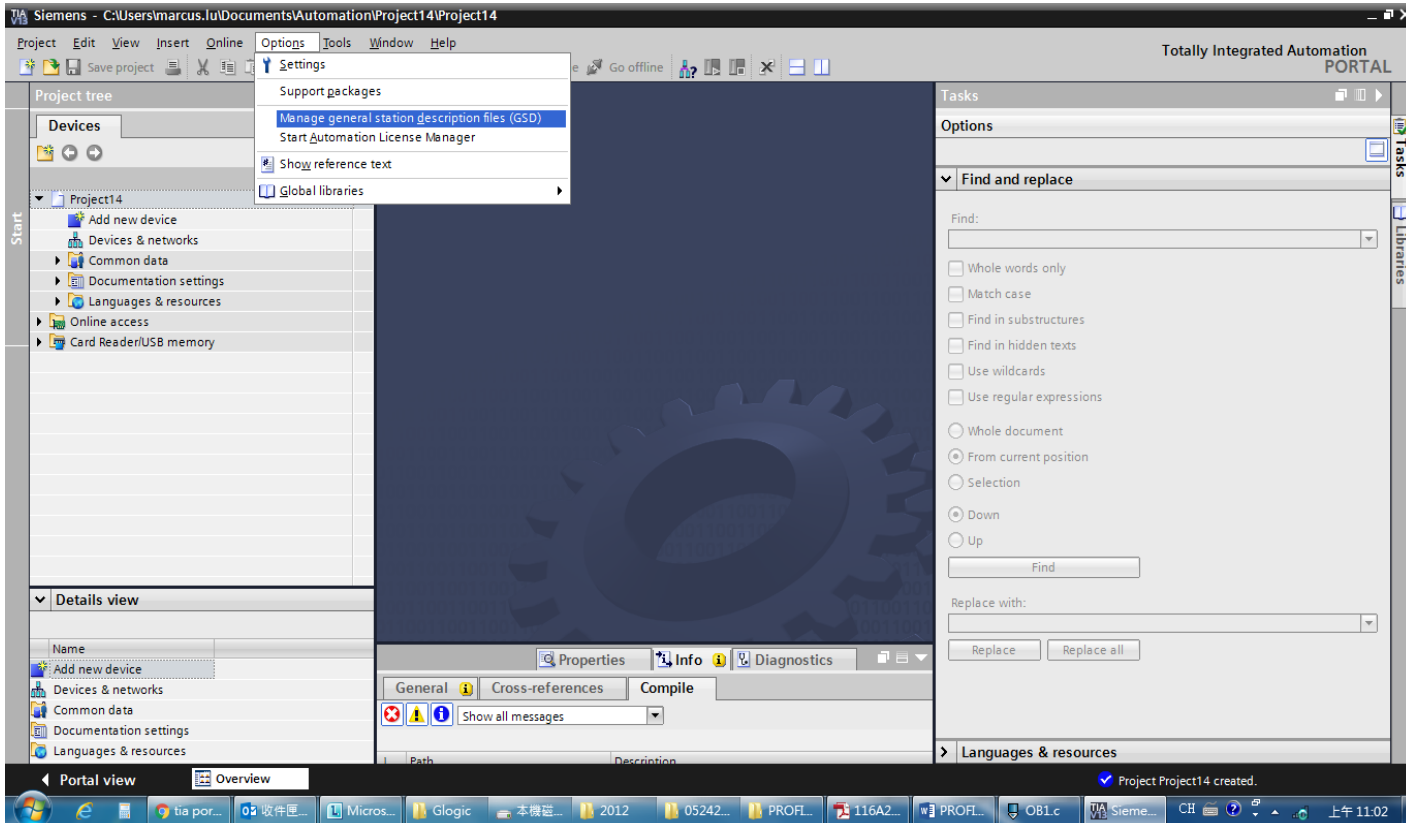

Select the path to save the GSDML file, select the GSDML file required to install, and then click **Install** button.

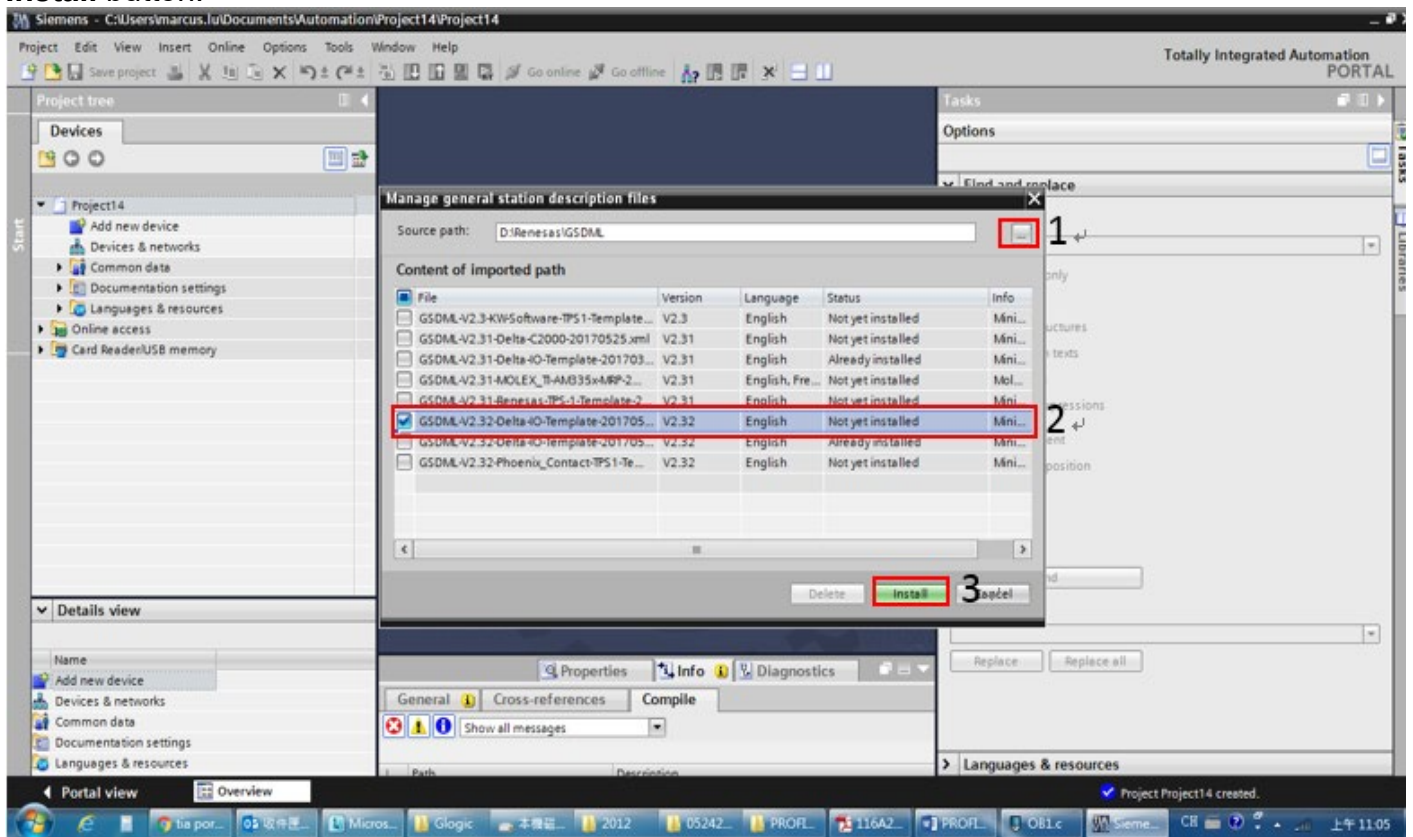

When the installation is completed, select **Devices & networks** and double-click it to check if the screen below displays. If the following screen displays, the installation is completed. If not, you must install again.

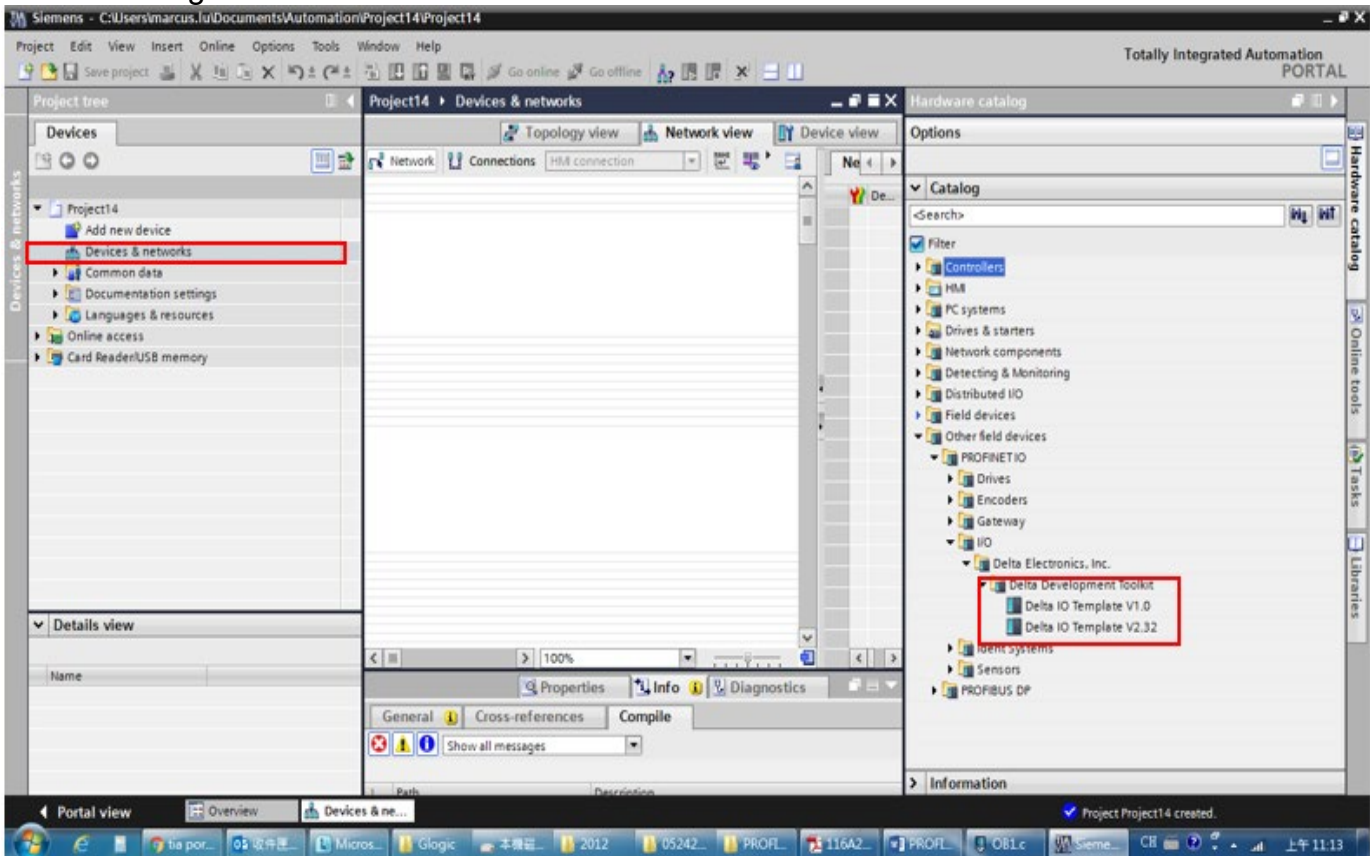

Select and double-click **Add new device**, the figure below displays.

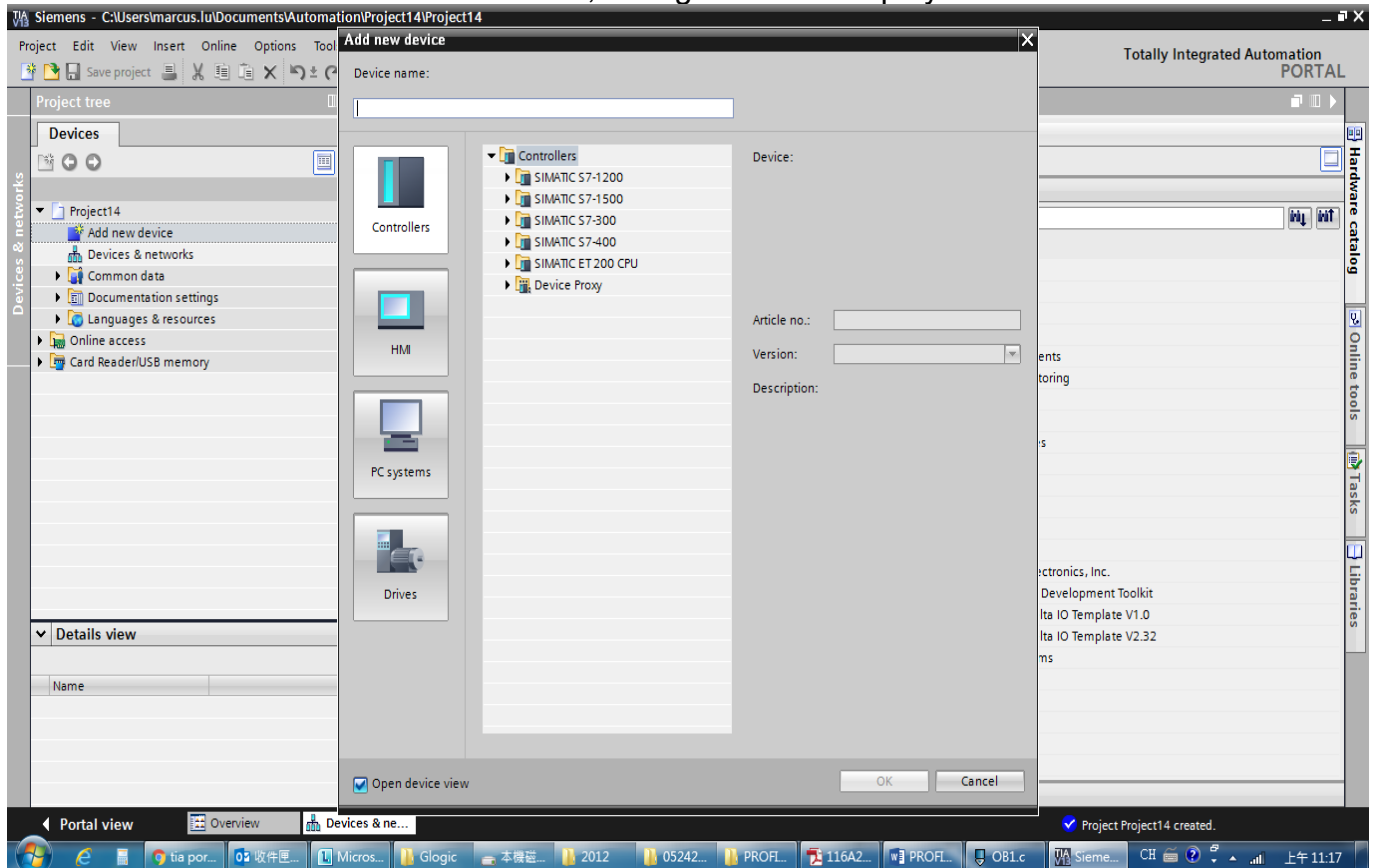



Select PLC's article No. and firmware version.

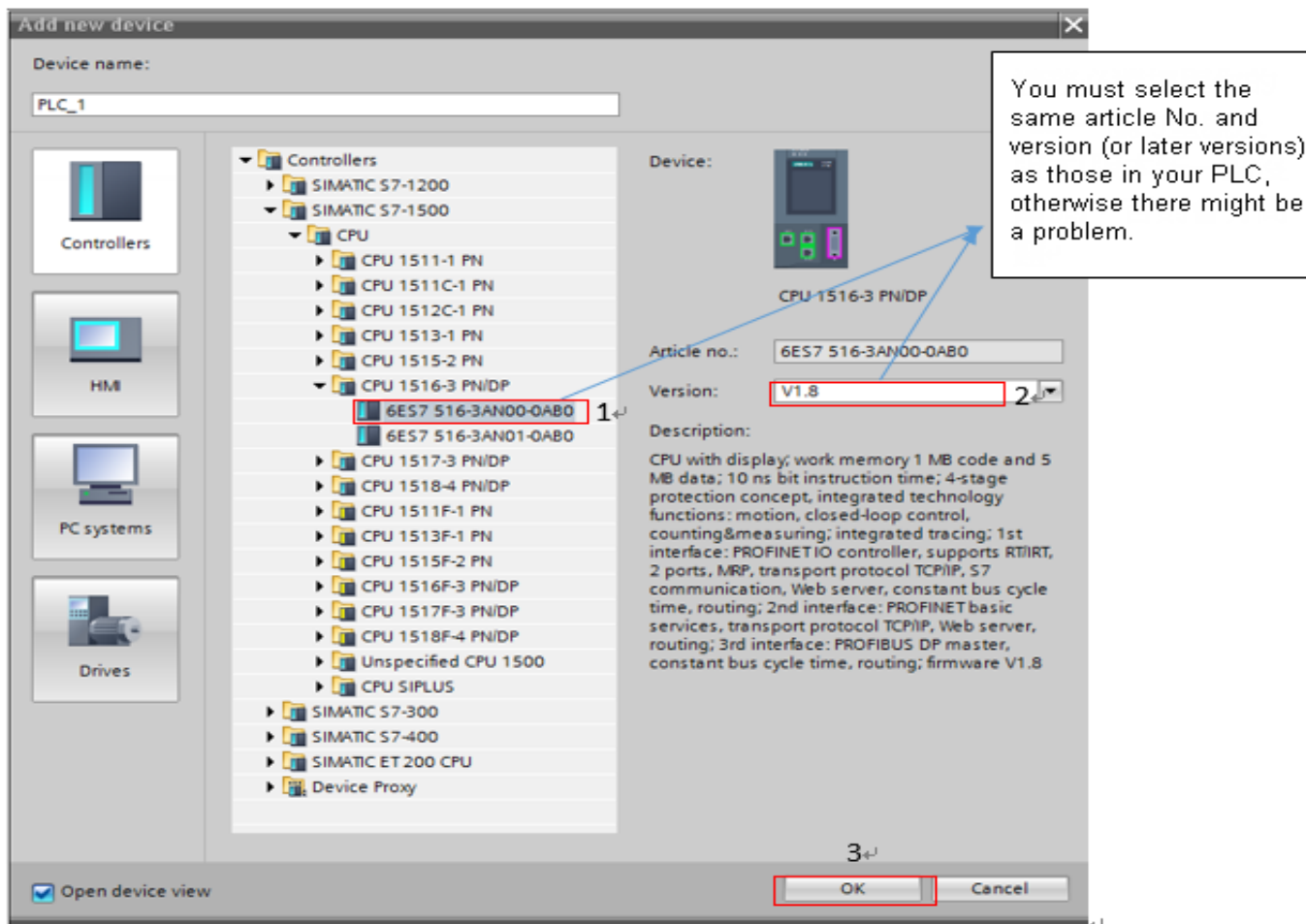

After you click **OK** button, a screen displays as shown in the figure below.

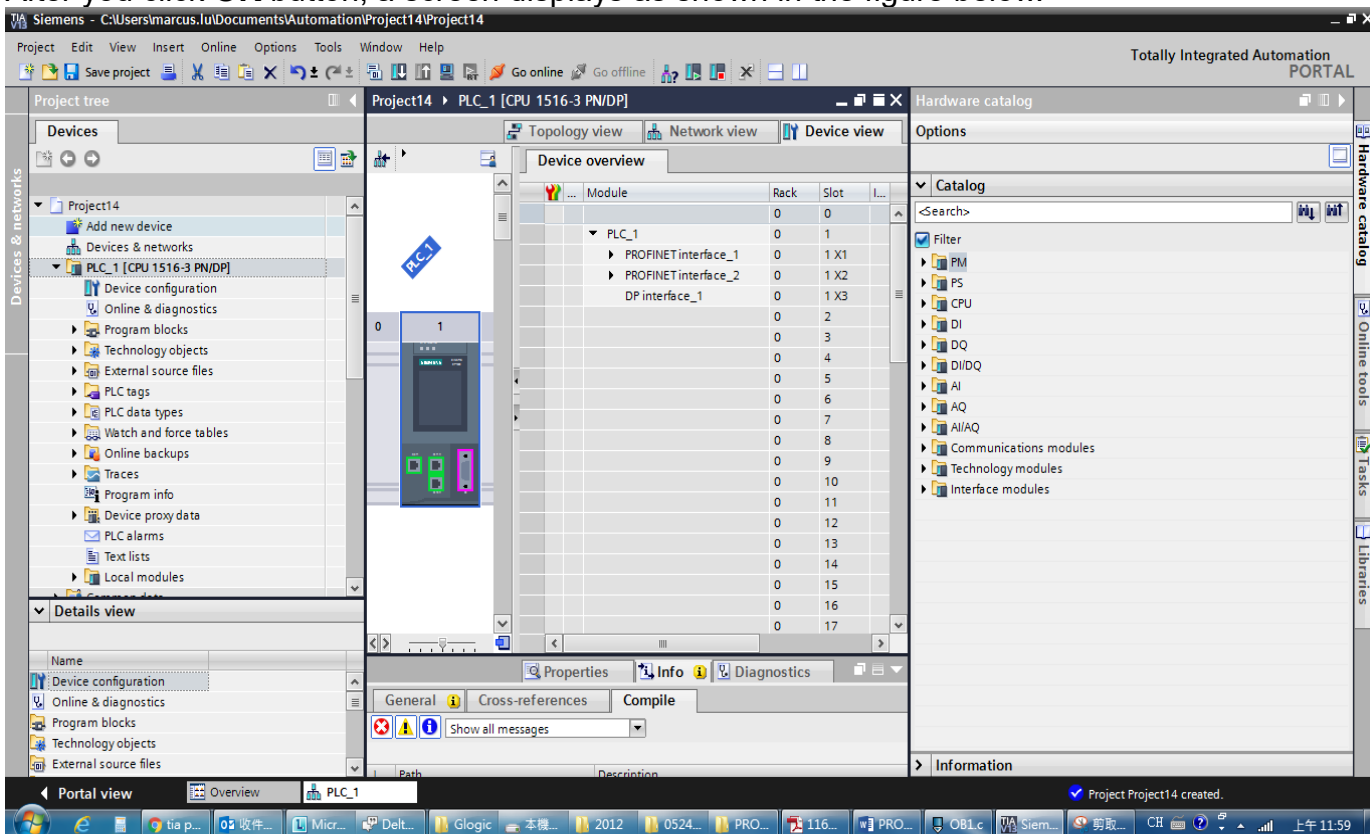

In the screen above, select **Network view**, a screen displays as shown in the figure below.

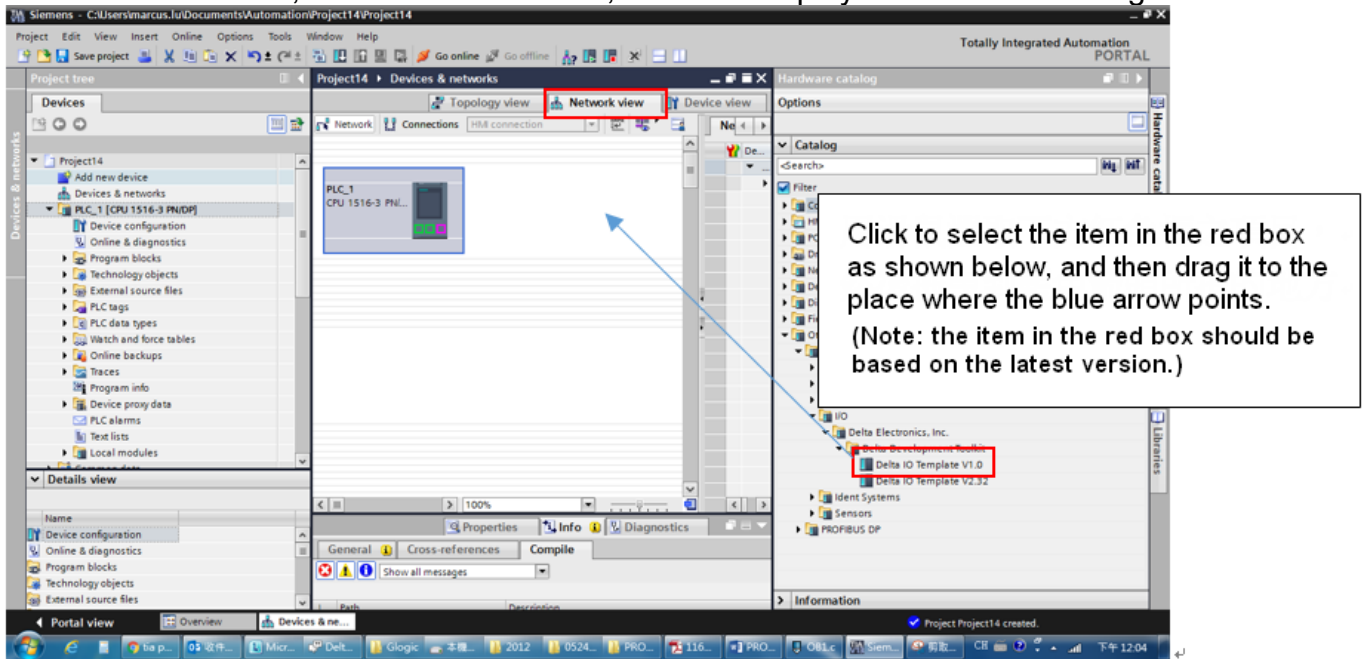

When the dragging is completed, a screen displays as shown in the figure below.

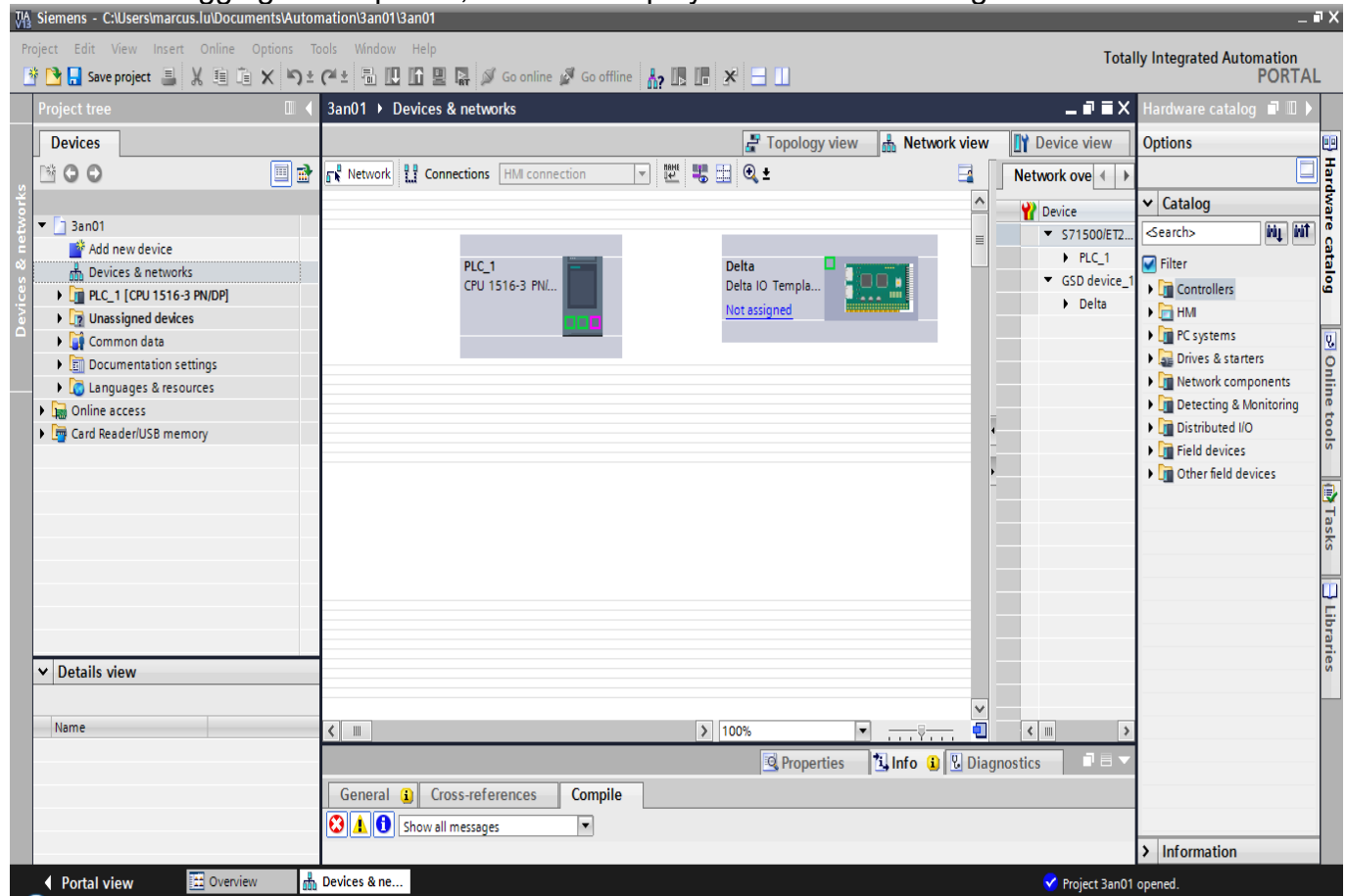

As the figure below shows, move the mouse to position 1 and drag it to draw a line to position 2.

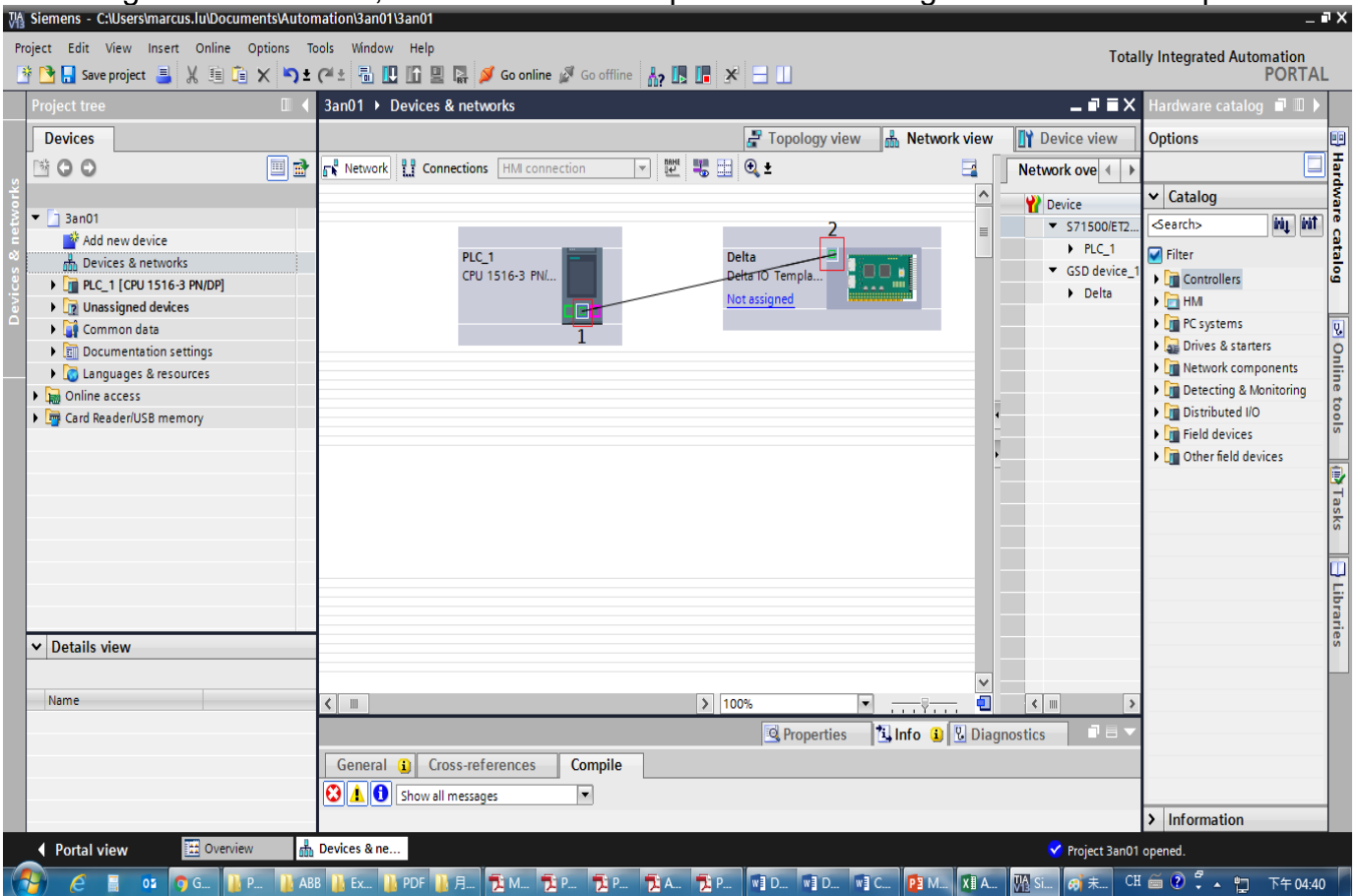

Then, a screen displays as shown in the figure below. If not, remove the drawing line and try another network interface. (It must be exactly the same as the figure below shows so the PROFINET framework is successfully completed.)

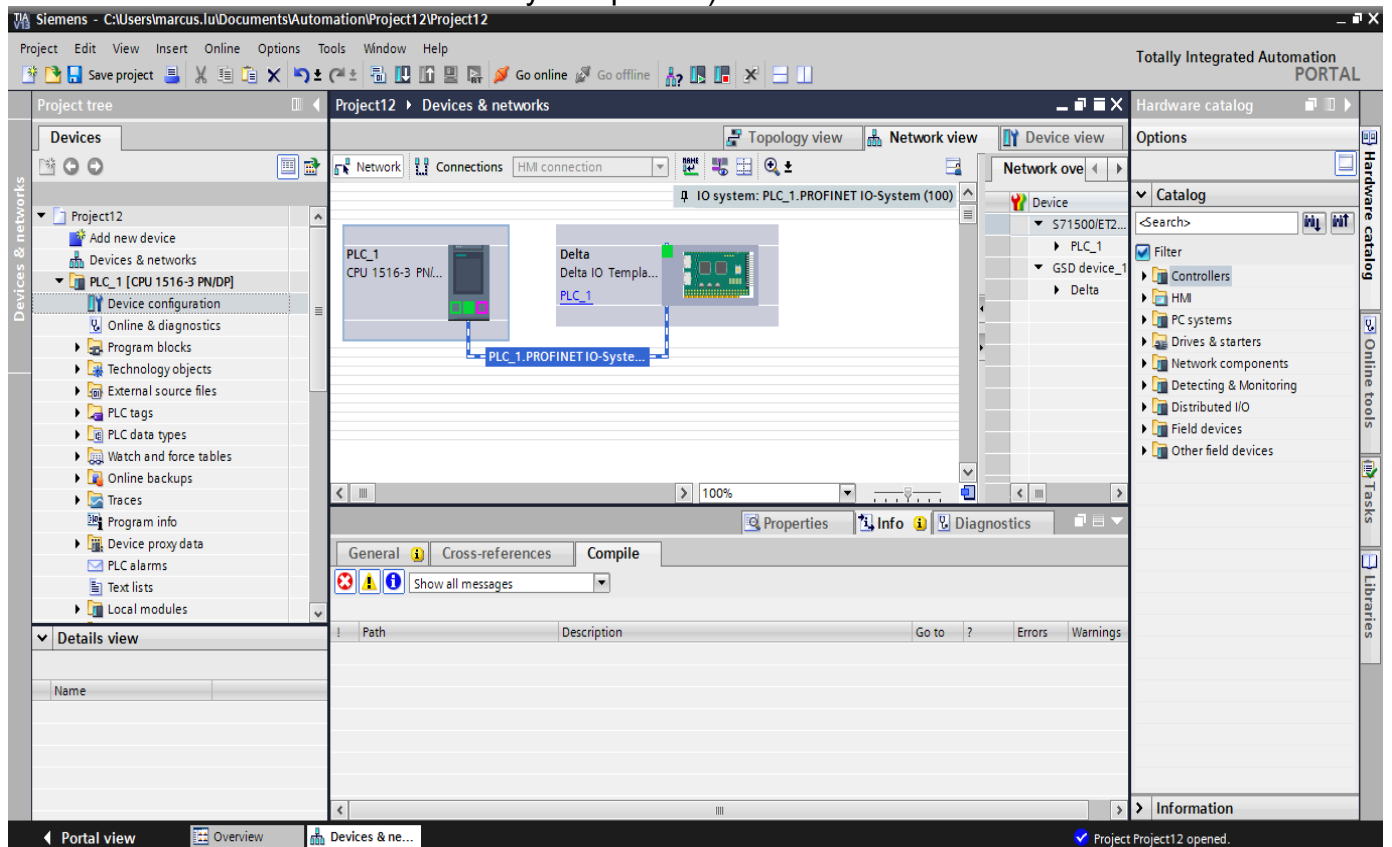

Double-click on the icon of CMM-PN02 card and enter the Device view, you can set the address x,y of the motor drive as described in Chapter 5 in the green box below. Besides, if your PLC has more than one POU, you can select the POU that the IO read/write corresponds to in the green box below.

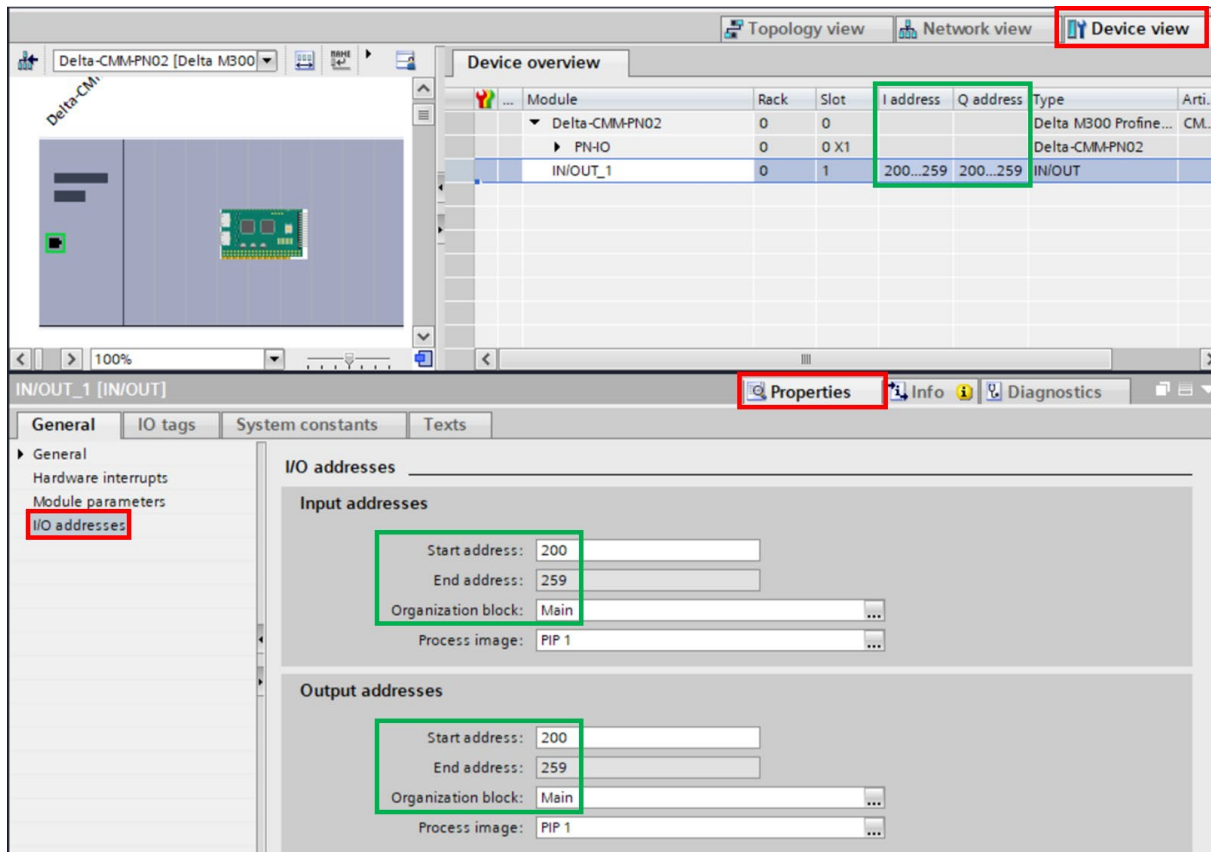

Now you can start to test the connection. Follow the steps as shown in the figure below to compile and download.

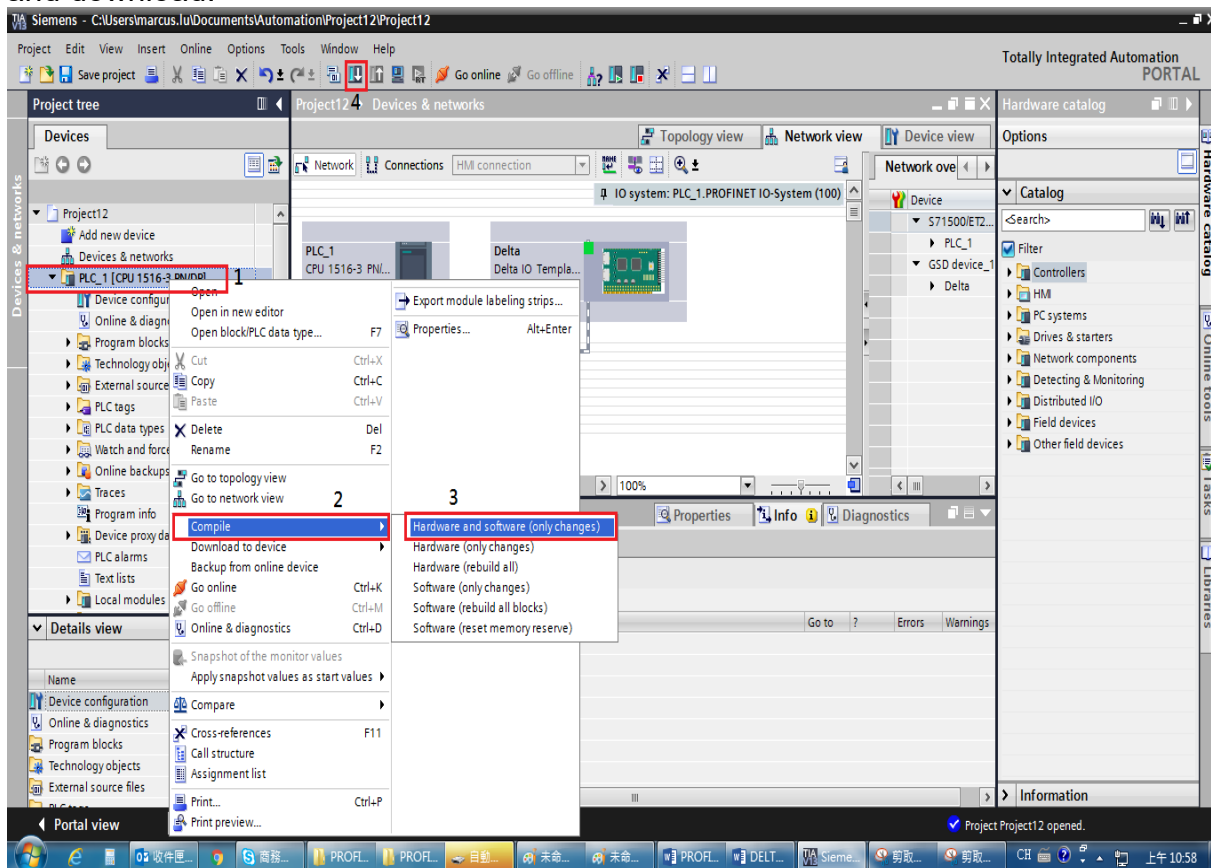

When S7-1500 is successfully connected, the status of LED and LCD panel shows as the figure below.



## ■ Testing the Start and Stop of the Drive

To verify if the host controller can control the drive through CMM-PN02, you must write PLC program.

For TIA PORTAL, the program-editing screen below illustrates an example of writing a program by using 60xx message format.

The screenshot displays the Siemens TIA Portal interface. The main window shows a ladder logic program for a PLC. The program is titled 'Main [OB1]' and is located in the 'Program blocks' of 'PLC\_1 [CPU 1516-3 PN/DP]'. The program is written in STL (Statement List) format. The main loop (Network 2) contains the following instructions:

```

1  L   "Tag_4"
2  L   6000
3  ==I
4  JCN RES
5  L   128
6  T   "Tag_5"
7  RES: NOP 0
8  L   "Tag_4"
9  ==I
10 JCN END
11 L   129
12 T   "Tag_5"
13
14 END: NOP 0

```

The right-hand side of the screen shows the 'Instructions' palette, which is currently expanded to show 'Basic instructions'. The 'Name' column of the palette lists various instruction categories, including Bit logic operations, Timer operations, Counter operations, Comparator operations, Math functions, Move operations, Conversion operations, Program control operations, Word logic operations, Legacy, and STL Mnemonic.

1. IW260 means 6102H (actual output frequency).
2. QW256 means 6000H (control word).
3. The writing of the program explains as follows.  
OB1 Program (Main Loop) is explained as follows:
  - a. Judging if IW260 (6102H) equals to 6000. If YES, PQQW256 (6000H) equals to 128 (0x80), which means the drive stops running; if NO, go to RES label;
  - b. Judging if PIW260 (6102H) equals to 0. If YES, PQQW256 (6000H) equals to 129 (0x81); if NO, go to END label;

Therefore, the drive performs continuous actions of running until stop, and then starts running again.

Example 2: (output deviation x = output deviation y =276)

Below is the TIA PORTAL program-editing screen and an example of writing a program by using 20xx message format.

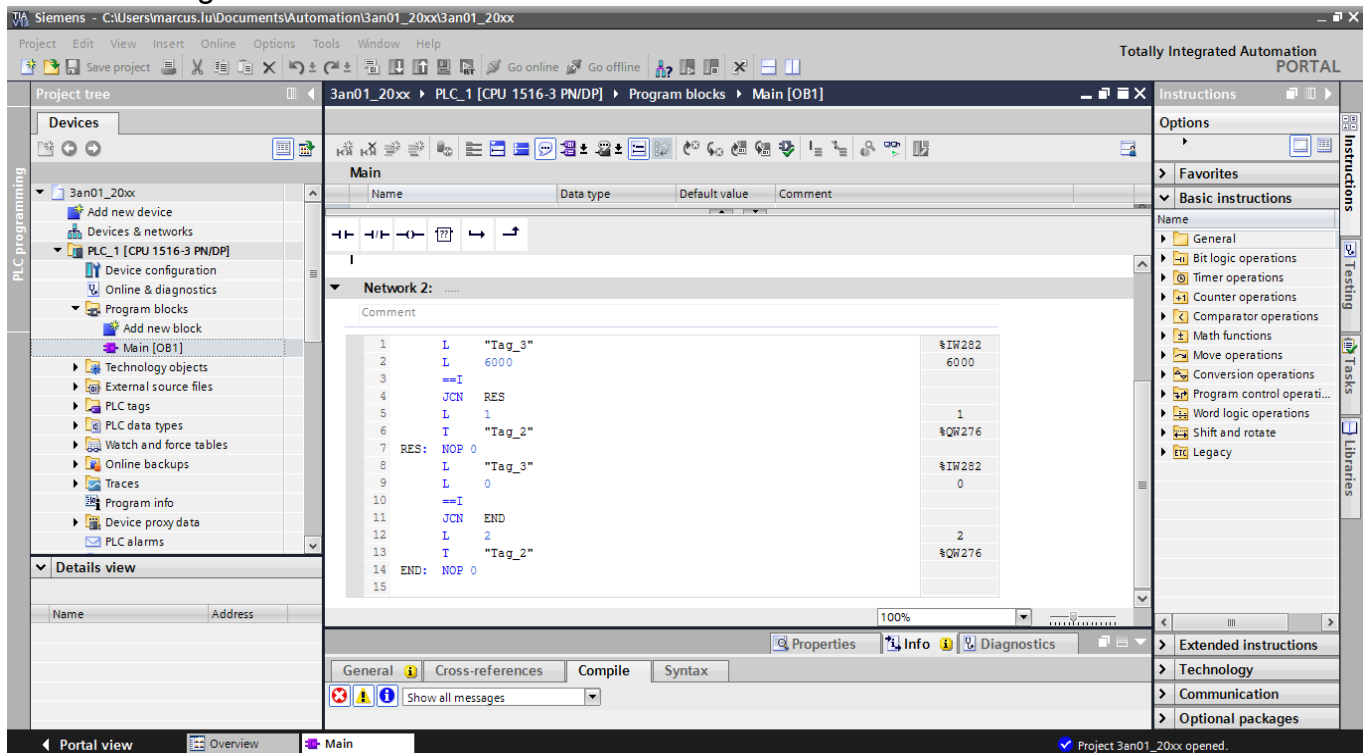

1. IW282 means 2103H (output frequency).
2. QW276 means 2000H (control word).
3. The writing of the program explains as follows.  
 OB1 Program (Main Loop) is explained as follows:
  - a. Judging if IW282 (2103H) equals to 6000. If YES, QW276 (2000H) equals to 1, which means the drive stops running; if NO, go to RES label;
  - b. Judging if IW282 (2103H) equals to 0. If YES, QW276 (2000H) equals to 2, which means the drive starts running; if NO, go to END label;

Therefore, the drive performs continuous actions of running until stop, and then starts running again.

Example 3: (Output deviation X = Output deviation y = 200)

If you use a ladder diagram, you can implement the program below.

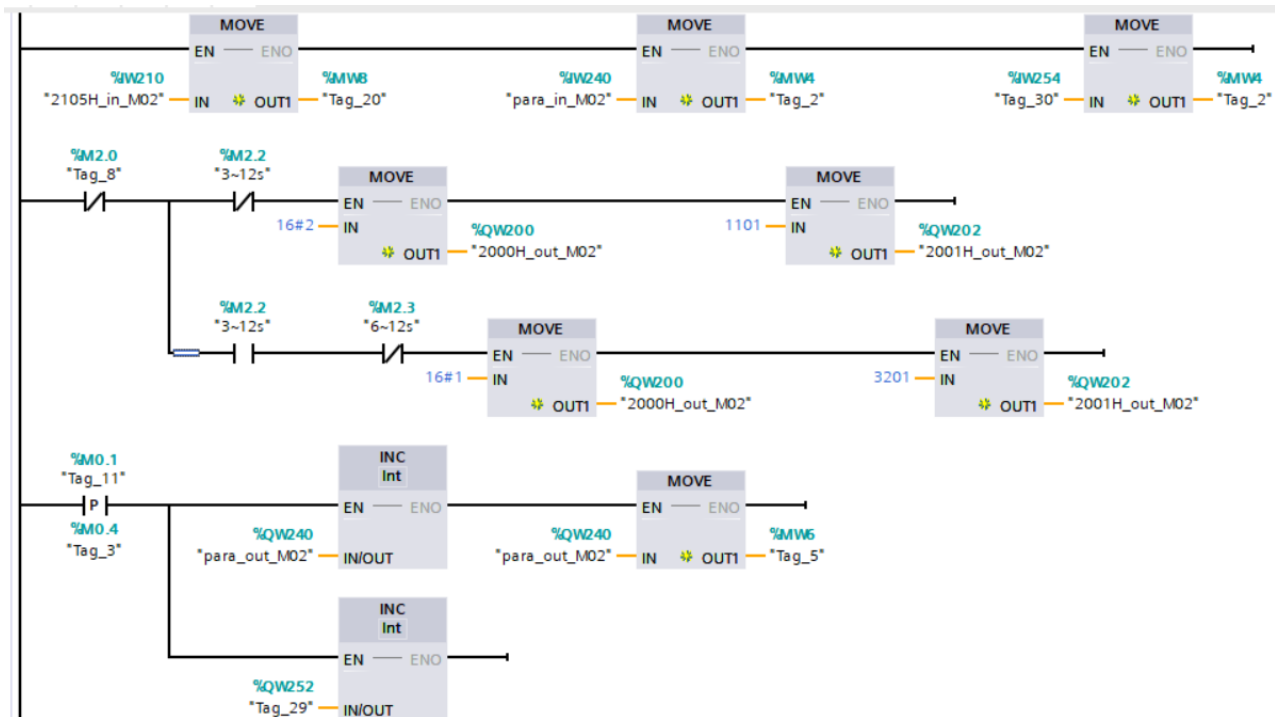

The first row maps 2105H of the motor drive through %IW210, %IW240, %IW254. It defines read parameter 1 and read parameter 8 and puts them into internal variable %MW.

The second to third rows are for the motor drive control writing. Take address 2000 as an example, when the second row indicates 0~3 seconds, use %QW200 to map 2000H to start the motor drive. Then use %QW202 to map 2001H of the motor drive to set the frequency command to 11.01Hz. When the third row indicates 3~12 seconds, stop the motor drive and set the frequency command to 32.01Hz.

The fourth row and the fifth row are for the motor drive periodic parameter writing. Increase %QW240 and %QW252 regularly so that the motor drive's user-defined writing parameter 1 and user-defined writing parameter 7 can be increased.

**NOTE:** For the address setting of the user-defined parameters, refer to the description of parameter reading and writing in the following sections.



## 6.4 Demonstration of Reading/Writing Synchronous and Asynchronous Parameters (S7-300 + TIA PORTAL)

### ■ Settings for Reading and Writing Synchronous Parameters of the Drive

The following example is demonstrated by using Siemens CPU315-2 PN/DP and TIA Portal V13 SP1. Refer to examples from previous chapter for the periodic programming implementation.

1. Follow the four steps as shown in the figure below to open Module Parameters.

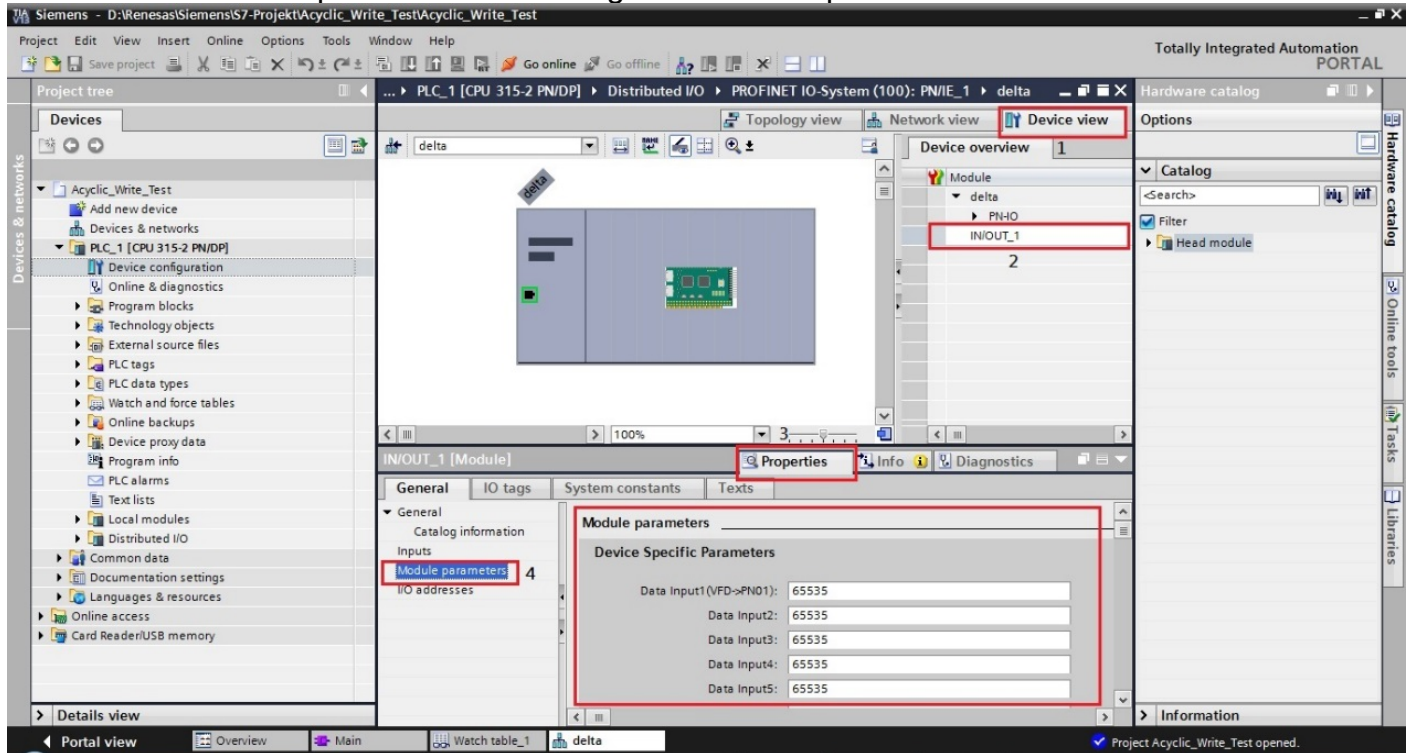

2. The figure below shows a complete parameter table. You can synchronously read or write the parameters of the drive by setting up this table. If the value of the parameters is 65535(0xFFFF), there is no parameter reading or writing.

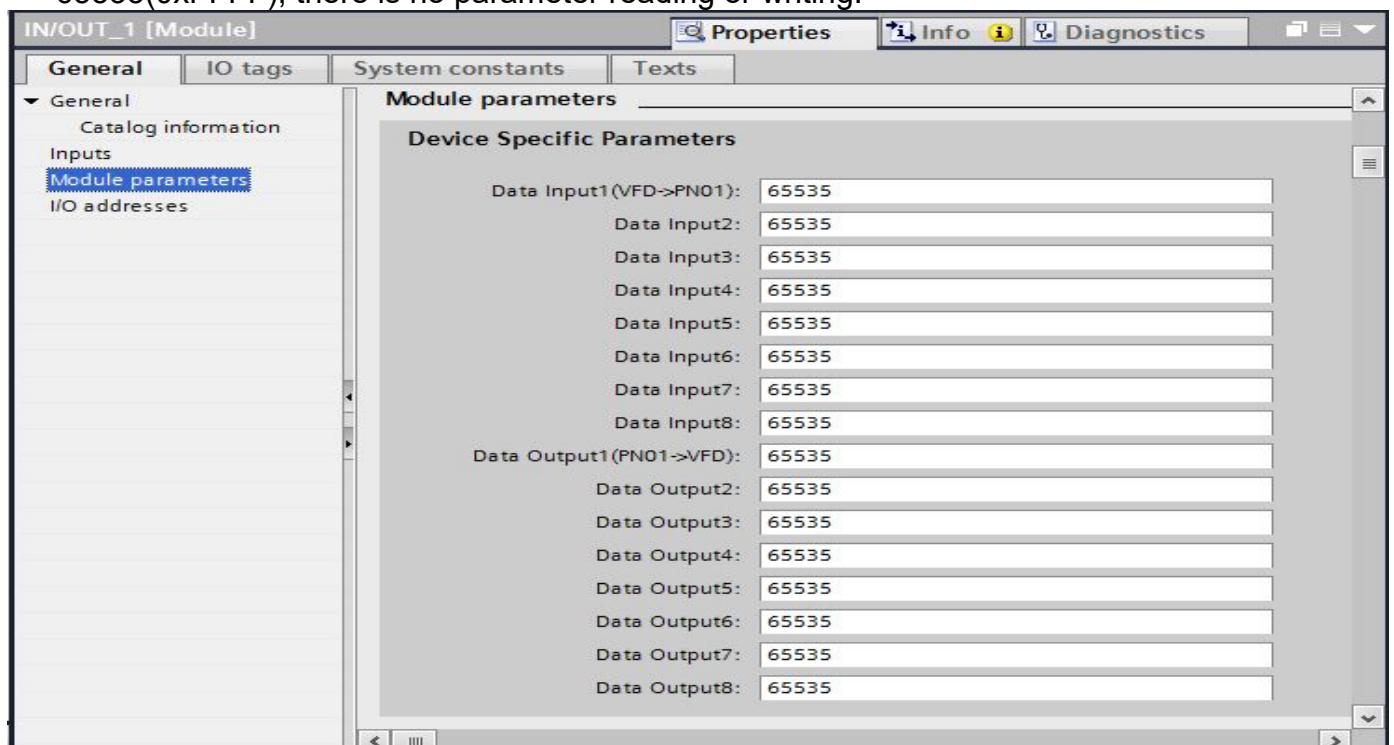

3. The figure below shows that you read Pr.01-00, Pr.01-10 and Pr.09-00 and write Pr.01-00 and Pr.09-00.

Device Specific Parameters		
Data Input1 (VFD->PN01):	256	01-00(0x0100)
Data Input2:	266	01-10(0x010A)
Data Input3:	65535	
Data Input4:	65535	
Data Input5:	65535	
Data Input6:	65535	
Data Input7:	65535	
Data Input8:	2304	09-00(0x0900)
Data Output1 (PN01->VFD):	256	01-00(0x0100)
Data Output2:	65535	
Data Output3:	65535	
Data Output4:	65535	
Data Output5:	65535	
Data Output6:	65535	
Data Output7:	65535	
Data Output8:	2304	09-00(0x0900)

Thus, to synchronously read or write the drive parameters through the PLC program, simply add 40 bytes to the start address of the I/O address. The added value is the home position of the parameter table. Take the figure above as an example, to read the values from Pr.01-00 in the PLC program, read %IW296:P. Similarly, to write the values in Pr.01-00 in the PLC program, write %QW296:P.

If you do not know the start address of the I/O address, refer to the figure below and follow the four steps to open the I/O Address.

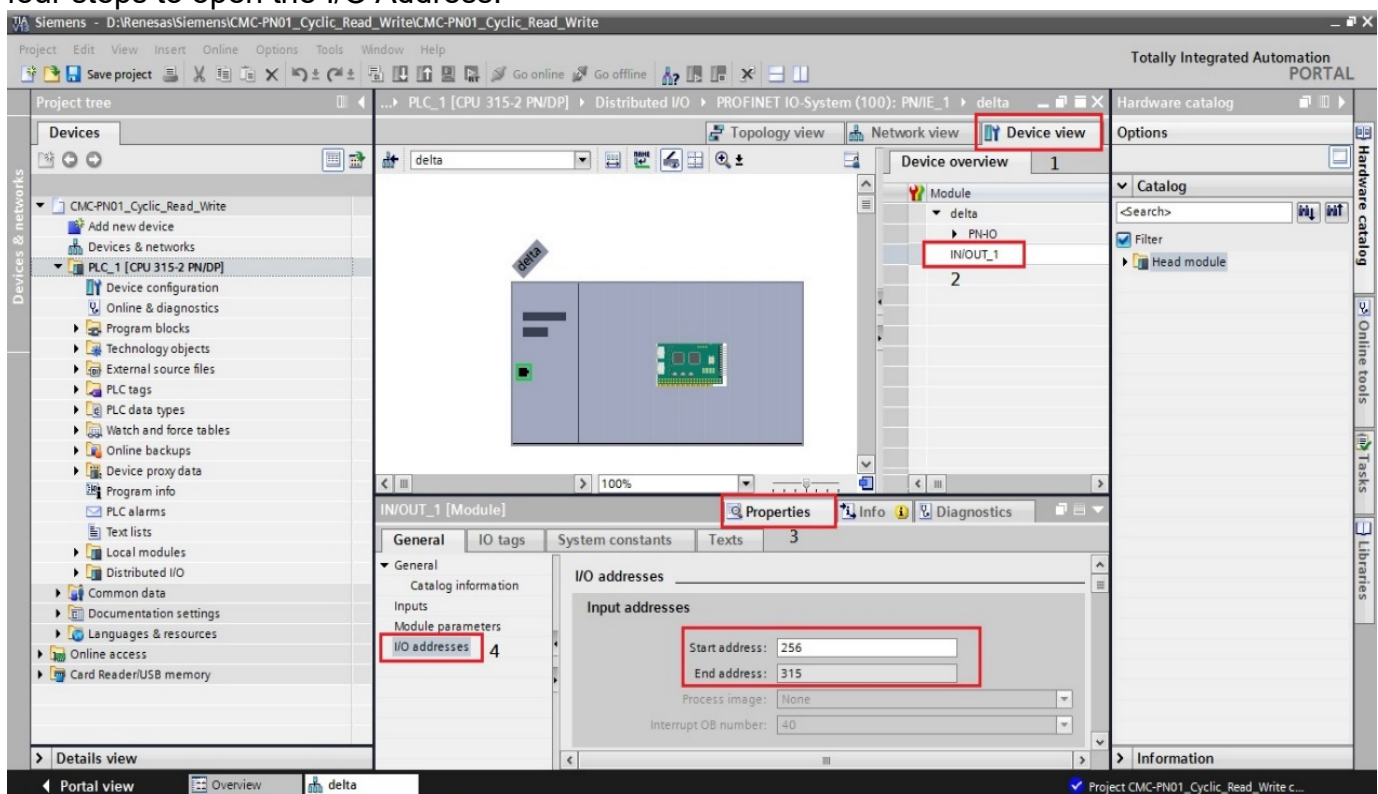

4. After you finish setting up the parameter table, recompile the programs and download them to the PLC program, and then reboot the drive to make CMM-PN02 receive the updated parameter settings.
5. When CMM-PN02 is connected to the PLC program successfully, you can test the reading or writing of the set parameter by using the Watch Table. Refer to the figure below for The Watch Table.

Follow the four steps below to verify if the settings for the parameter table are applicable and if reading or writing the drive parameters is successful (Use the keypad to verify.).

Name	Address	Display format	Monitor value	Monitor with trig...	Modify with trigge	Modify value	Co...
1	%IW296:P	Hex	16#1338	Permanent	Permanent		01...
2	%IW298:P	Hex	16#E9FC	Permanent	Permanent		01...
3	%IW310:P	Hex	16#0002	Permanent	Permanent		09...
4	%IW312:P	Hex	16#8183	Permanent	Permanent		Rea...
5	%QW296:P	Hex		Permanent	Permanent	16#1338	01...
6	%QW310:P	Hex		Permanent	Permanent	16#0002	09...

**NOTE 1:** The figure above shows that %IW312 is the status value returned when the parameter table reads or writes the parameters. Low byte is the status value of reading, whereas high byte is the status value of writing. Take the figure above as an example, if the status value is 0x8183, the values of 1, 2, and 8 in the parameter table are successfully read and the values of 1 and 8 are successfully written. Thus, the success or failure of the parameter reading/writing depends on this status value.

**NOTE 2:** %IW312 = I/O start address + 56 (the I/O start address in this example is 256).

**NOTE 3:** Depending on the immediacy of the data, you can choose to write the parameters periodically or non-periodically,

■ Non-Periodic Parameter Read/Write Setting of the Motor Drive

Non-Periodic writing:

1. As shown in the figure below, first set up the corresponding connection configuration. Left-click the red box in the figure from top to bottom and record the hardware identifier of the PN-IO.

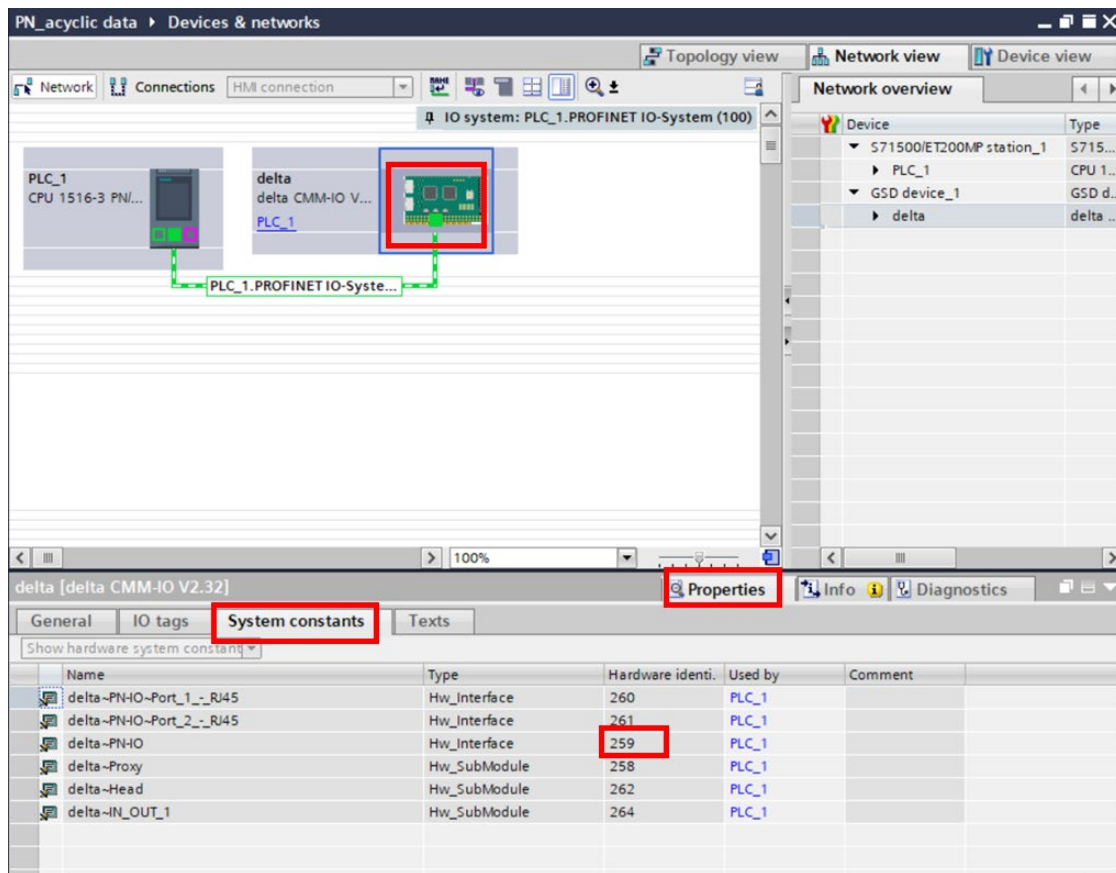

**NOTE:** In the older versions of TIA PORTAL, the ID values of the function blocks above can be read in the following locations.

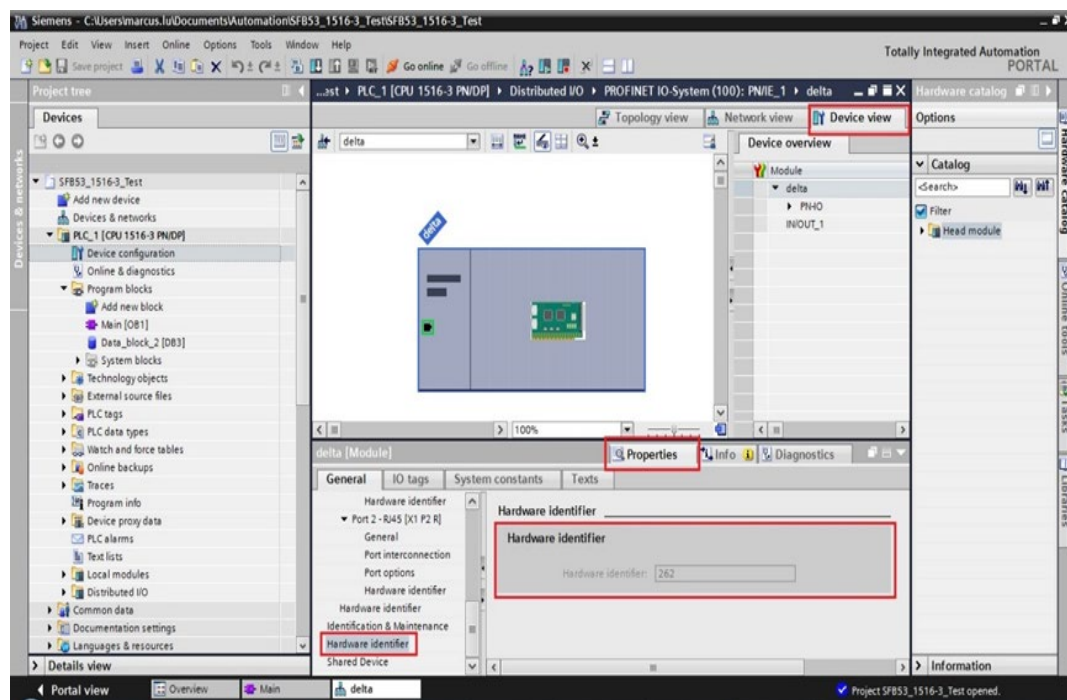

2. As shown in the figure below, after turning on the OB1, drag the WRREC in the extended instruction on the right side into the network.

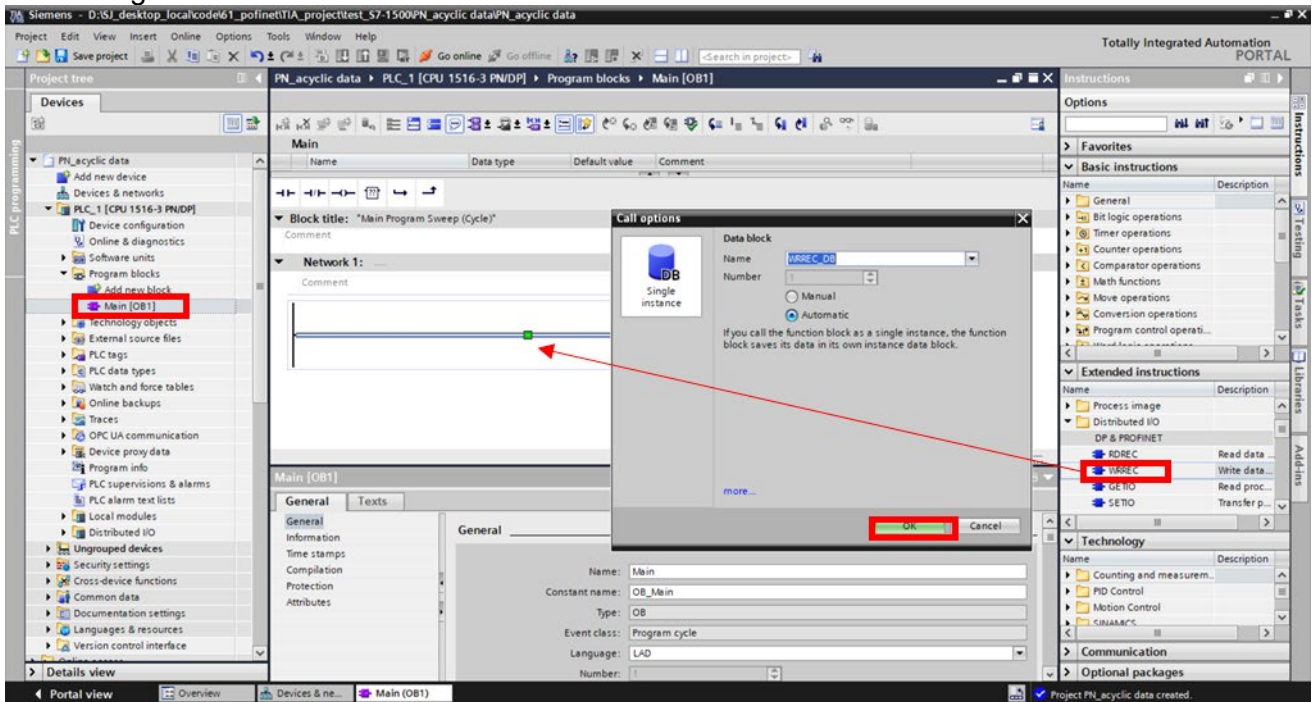

3. Follow the three steps in the figure below to add Array\_DB.

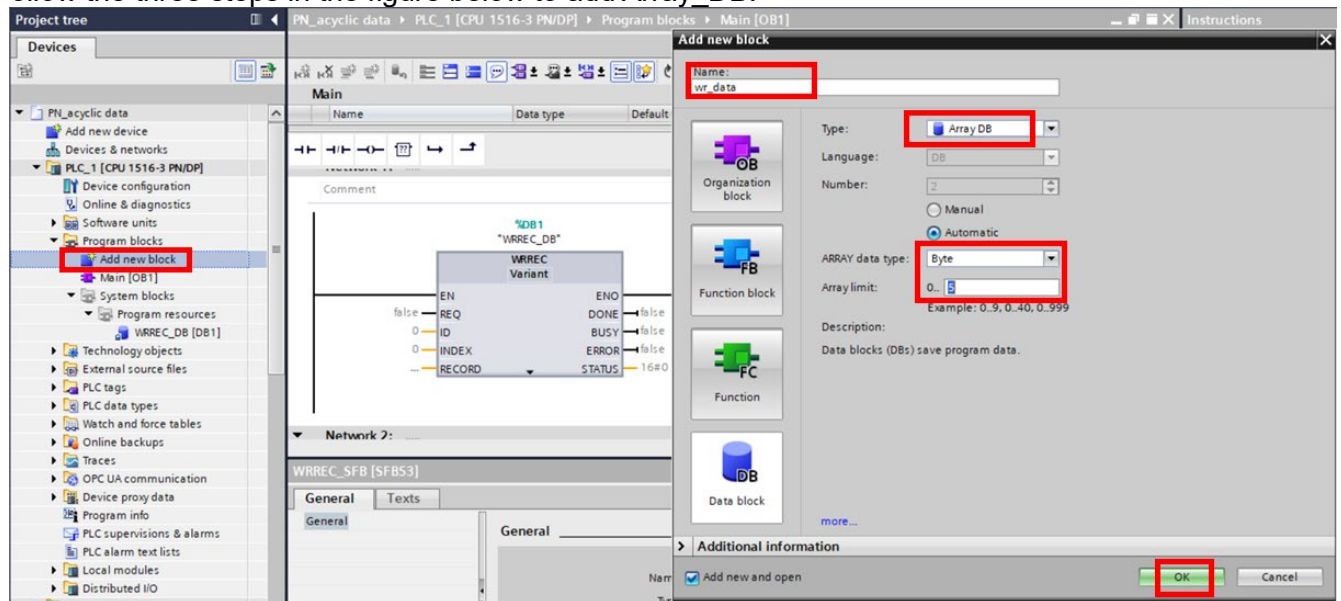

4. Left click to drag and drop the new Array into the corresponding pane of the block and fill in the relevant information of the packet being sent. The REQ here indicates whether the function is enabled or disabled. The ID here can use the hardware number recorded in the first step. The INDEX here is the number of the record data object. The CMM-PN02 can use the function number 1234 to notify the motor drive that it needs to do parameter writing. Note that the length of writing parameter should be 6.

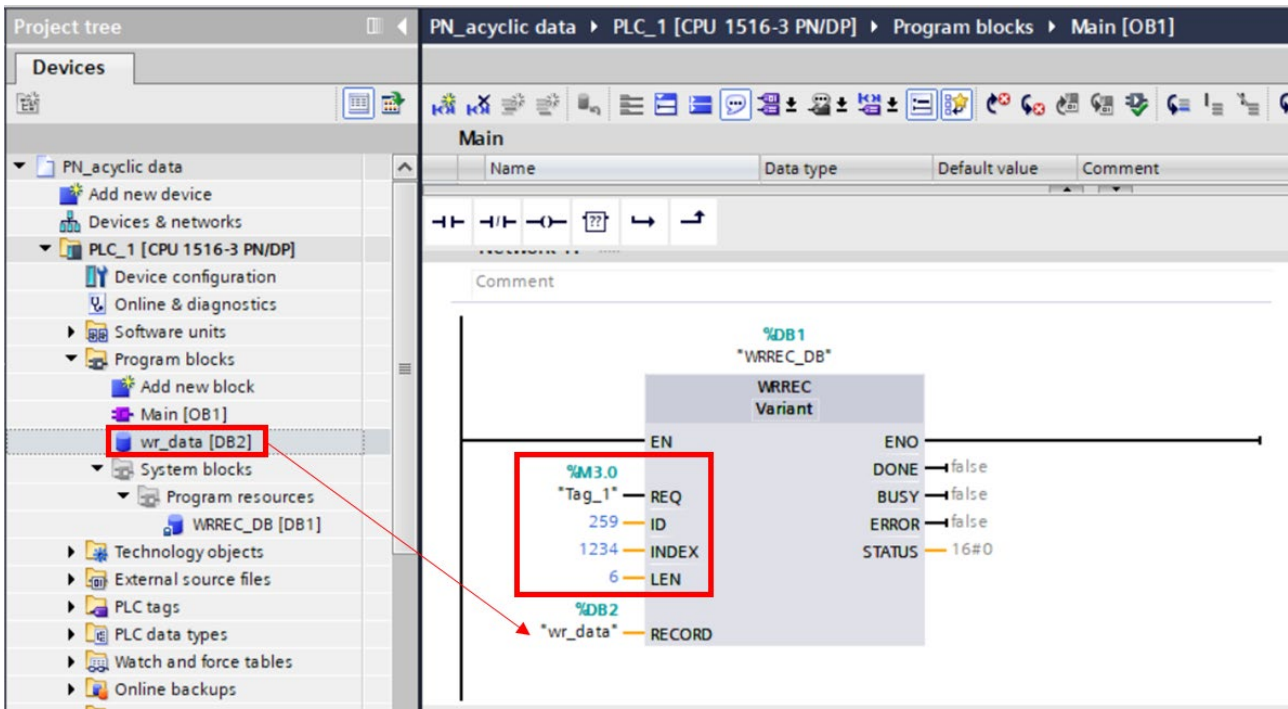

5. Recompile the PLC program and download it to the PLC.
6. Refer to the figure below, set the array value of wr\_data via Watch Table, then go to the motor drive to verify whether the corresponding parameter is written or not.

	Name	Address	Display format	Monitor value	Modify value	
1	"rd_data".THIS[0]		Hex	16#10		<input type="checkbox"/>
2	"rd_data".THIS[1]		Hex	16#01		<input type="checkbox"/>
3	"wr_data".THIS[0]		Hex	16#FF		<input type="checkbox"/>
4	"wr_data".THIS[1]		Hex	16#06	16#06	<input checked="" type="checkbox"/>
5	"wr_data".THIS[2]		Hex	16#04		<input type="checkbox"/>
6	"wr_data".THIS[3]		Hex	16#33		<input type="checkbox"/>
7	"wr_data".THIS[4]		Hex	16#22	16#22	<input checked="" type="checkbox"/>
8	"wr_data".THIS[5]		Hex	16#33	16#33	<input checked="" type="checkbox"/>
9	"Tag_12"	%MW33	DEC	6	6	<input checked="" type="checkbox"/>
10	"Tag_10"	%M3.0	Bool	<input checked="" type="checkbox"/> TRUE	TRUE	<input checked="" type="checkbox"/>
11	"Tag_9"	%M3.1	Bool	<input checked="" type="checkbox"/> TRUE	TRUE	<input checked="" type="checkbox"/>
12	<Add new>					<input type="checkbox"/>

**NOTE:** The demonstration above uses FF 06 YY YY XX XX to write motor drive parameters. (YY YY stands for parameter group and number, e.g. 16#0433 is Pr.04-51.) (XX XX represents the value to be written, e.g. 16#22 33)

## Non-Periodic reading:

- When OB1 is turned on, fill in the RDREC function underneath the original WRREC in a non-periodic writing method.

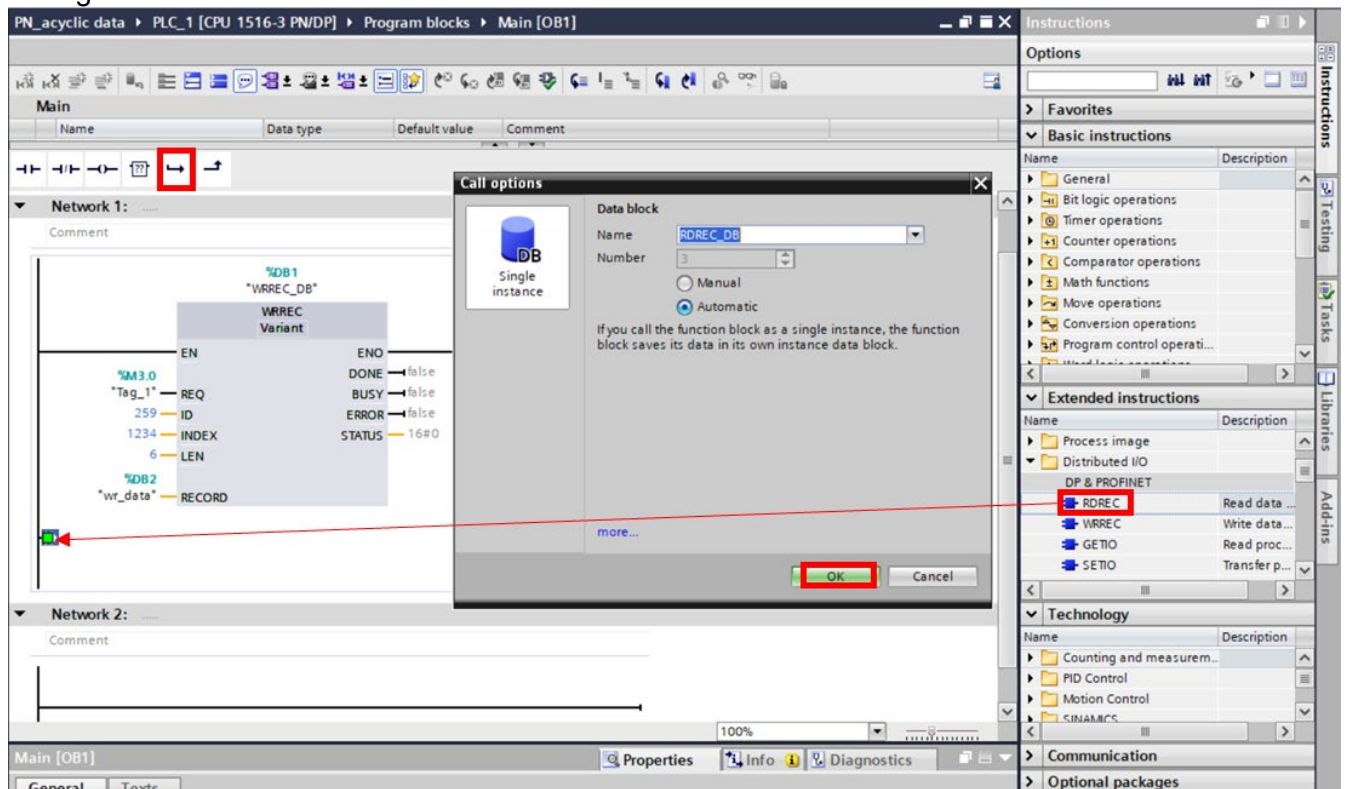

- Add a new ARRAY data (it's called rd\_data) and fill in the corresponding values for the API to read. The REQ here indicates whether the function is enabled or not. The ID here can use the hardware number recorded at the beginning. The INDEX here is the number of the record data object. The CMM-PN02 can use the function number 1234 to notify the motor drive that it needs to do parameter writing. Note that the length of this WRREC write should be 4.

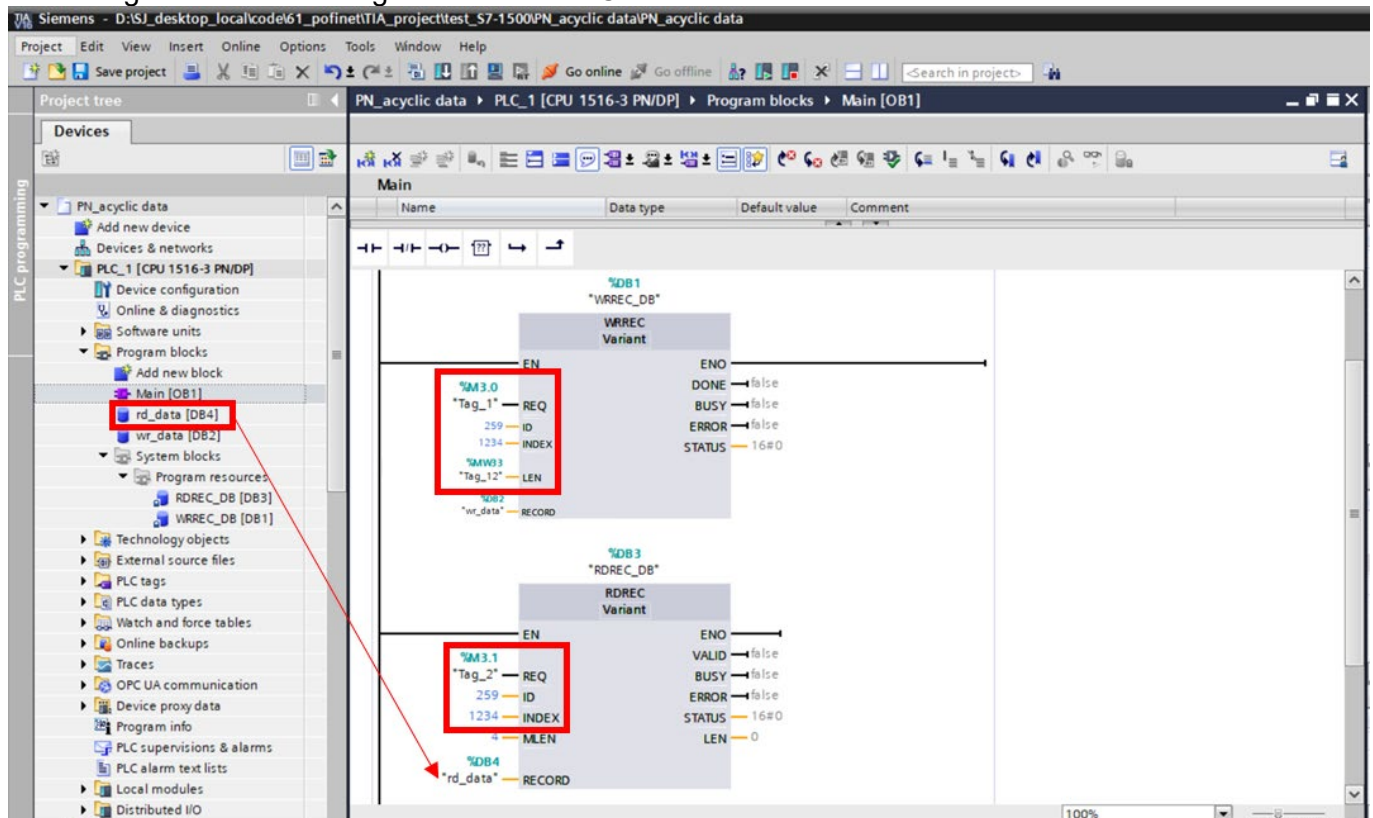

3. Recompile and download the PLC program.
4. Test if the program is set up successfully via Watch Table. Refer to the figure below for setting.

	i	Name	Address	Display format	Monitor value	Modify value	
1		"rd_data".THIS[0]		Hex	16#10		<input type="checkbox"/>
2		"rd_data".THIS[1]		Hex	16#01		<input type="checkbox"/>
3		"wr_data".THIS[0]		Hex	16#FF		<input type="checkbox"/>
4		"wr_data".THIS[1]		Hex	16#03	16#03	<input checked="" type="checkbox"/> ⚠
5		"wr_data".THIS[2]		Hex	16#04		<input type="checkbox"/>
6		"wr_data".THIS[3]		Hex	16#33		<input type="checkbox"/>
7		"wr_data".THIS[4]		Hex	16#10		<input type="checkbox"/>
8		"wr_data".THIS[5]		Hex	16#01		<input type="checkbox"/>
9		"Tag_12"	%MW33	DEC	4	4	<input checked="" type="checkbox"/> ⚠
10		"Tag_10"	%MB.0	Bool	TRUE	TRUE	<input checked="" type="checkbox"/> ⚠
11		"Tag_9"	%MB.1	Bool	TRUE	TRUE	<input checked="" type="checkbox"/> ⚠
12			<Add new>				<input type="checkbox"/>

**NOTE 1:** Before reading the parameters in the demonstration above, you need to call the WRREC function block to write FF 03 YY YY to change the mode of the communication card. Then call the RDREC function block to read the parameters of the motor drive (YY YY stands for the parameter group and the number, e.g., 16#0433 is the Pr.04-51.).

**NOTE 2:** The user can set REQ to decide whether to read the parameter or not.