



Digitized Automation for a Changing World

Delta AC Servo Drive & Motor ASDA-A3-EP Series

Delta High-End Servo Systems Extreme Speed, Precision, Stability, and Safety

The new **Delta High-Performance Servo System ASDA-A3-EP Series** features advanced Functional Safety capabilities and Delta's renowned high-performance servo functionalities. It ensures real-time responsiveness and precise positioning. This series delivers ultra-fast response times, creating a high-precision, highly efficient, and stable motion control.





Table of Contents

New

Comprehensive Safety Features	4
Functional Safety (FS) FailSafe over EtherCAT (FSoE) Safe Torque Off (STO)	
High Performance	7
3.1 kHz Bandwidth 24-Bit Absolute Type Encoder 6,000 r/min & 350 % Peak Torque Motors High & Low Inertia Rotor Motors Low Cogging Torque Motors Motor Compatibility Full-Closed Loop Control	
Multifunctional	9
Ethernet over EtherCAT, (EoE) File Access over EtherCAT (FoE) System Diagnosis Vibration Elimination Automatic Gain Tuning Advanced Notch Filters	
Built-In Motion Control	12
Capture and Compare	
Energy-Saving & Compact Size	12
DC-Bus Sharing Slim Servo Drives Compact Motors	
User-Friendly Software	14
Tree-View Display Graphical Interface for Parameter Settings Automatic Gain Tuning Wizard System Analysis in Bode Plots Oscilloscope Delta Drive Safety	
Product Information	16
Part Names and Functions Optional Accessories ASDA-Soft Configuration Software	
Ordering Information	22
Servo System Combination Table Servo Drive Models & Specifications Safety Module Description Safety Module Model Description Safety Module Specifications Servo Drive Dimensions ECM-B3 Servo Motors Models & Specifications ECM-B3 Servo Motors Dimensions	
Servo Drive Standards	55

Comprehensive Safety Features New

Functional Safety Features

- **Comprehensive Safety Functions:** 13 advanced safety features compliant with IEC 61508 SIL3 safety standards
- **Dual Activation Methods:** Supports activation via FSoE safety bus or I/O triggers. FSoE reduces wiring complexity and improves efficiency

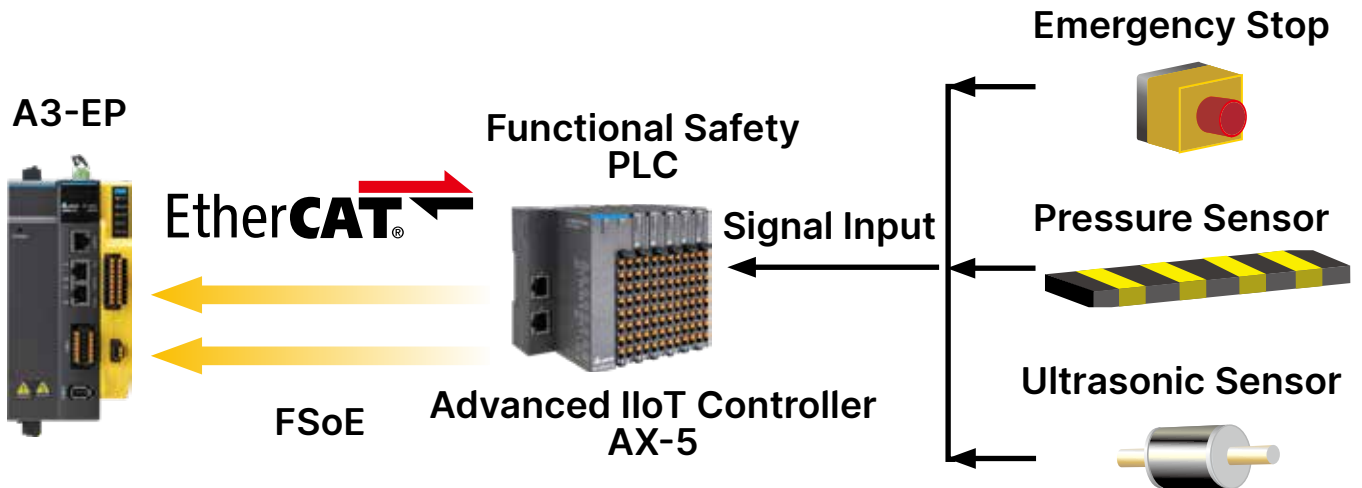

Safe Stop Functions

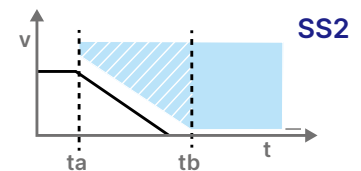
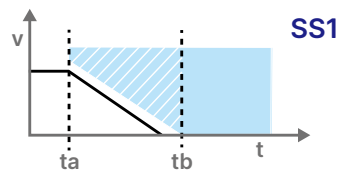
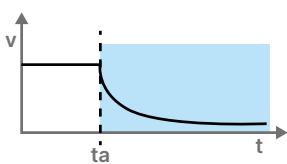

Safe Torque Off (STO)

- Disables the servo drive's output power. Motor may rotate without braking. Applications: Safety maintenance, emergency shutdown, preventing unintended start-up

Safe Stop 1 (SS1) -

Time-Controlled/Ramp Monitoring

- Motor decelerates to a stop within a defined time or slope, and auto-transitions to STO. Applications: High-speed operation or high risks of machine damage

Safe Stop 2 (SS2) -

Time-Controlled/Ramp Monitoring

- Servo drive decelerates to a stop within a defined time or slope. Motor torque stays available. Applications: Precise positioning and preventing unintended movement

Safety Monitoring Functions

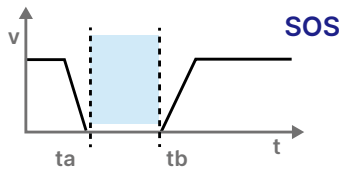

Safe Operating Stop (SOS)

- Servo drive stationary & motor servo-enabled for quick restarts with positional accuracy. Applications: Robot position adjustment

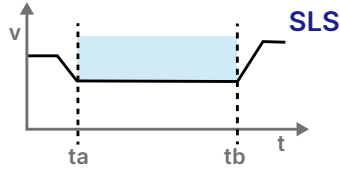

Safe Limited Speed (SLS)

- Monitors motor's operating speeds, which, if exceed a limit, triggers a stop or controlled deceleration

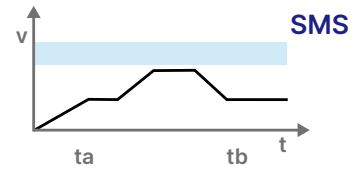

Safe Maximum Speed (SMS)

- Defines a static max. speed limit for the motor to ensure safe operation

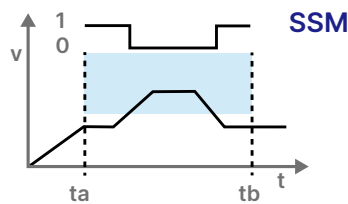

Safe Speed Monitoring (SSM)

- Continuously tracks the motor's operating speed and ensures it remains within a predefined safe threshold to allow operators to approach safely

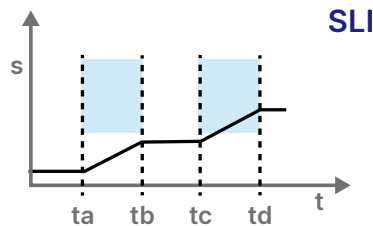

Safe Incremental Movement (SIM)

- Restricts motor displacement within a defined range over a specific time, preventing the motor from exceeding the designed space

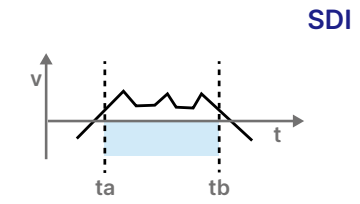

Safe Direction (SDI)

- Servo motor operates in the specified safe direction, preventing reverse movement. Particularly important for vertical motion machinery to avoid unintended load drops

Safe Output Functions

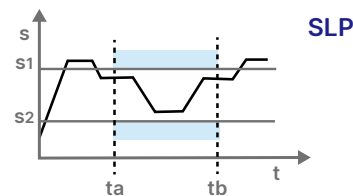

Safe Limited Position (SLP)

- Defines a safe operating range for the motor's movement. Applications: Industrial robots and lifting platforms

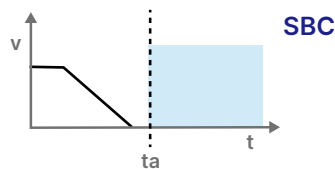

Safe Brake Control (SBC)

- Similar to STO & FSoE, but utilizes a dedicated output signal to engage the brake

Complete Safety Features

FailSafe over EtherCAT (FSoE)

- **High Integration:** Transmits standard data packets and safety data over the same network without requiring a separate safety bus. Compared to I/O-triggered methods, FSoE simplifies wiring, reduces installation and maintenance costs
- **High Reliability:** Includes robust error detection and validation mechanisms, such as **Cyclic Redundancy Check (CRC)** and timeout monitoring, which ensures data integrity and reliability when interference happens
- **Compliance with International Safety Standards:** Certified by TÜV and compliant with IEC 61508, SIL 3 and ISO 13849 PL e, meeting the highest industrial safety standards

Safe Torque Off (STO)

The built-in STO of the moving axis is triggered when the operator enters the protected areas to ensure safety

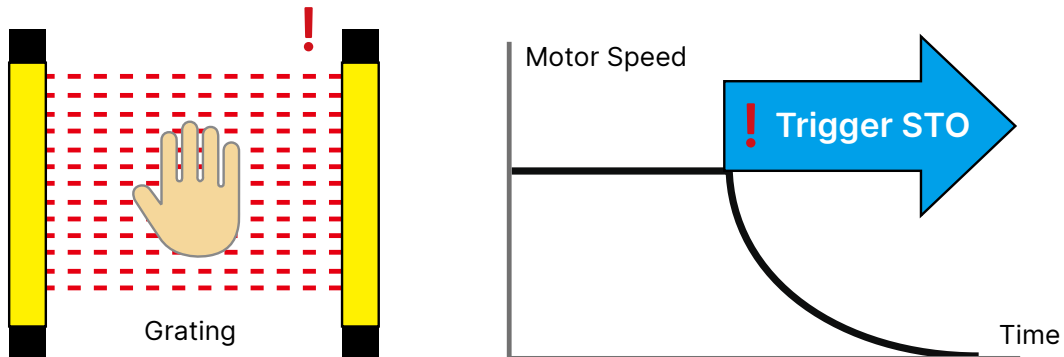

High Performance

3.1 kHz Bandwidth

- Tripled bandwidth enhances responsiveness and position control accuracy (compared to ASDA-A2)
- Shortens the settling time to increase productivity

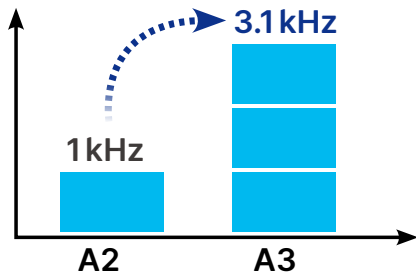

Closed-Loop Speed Control

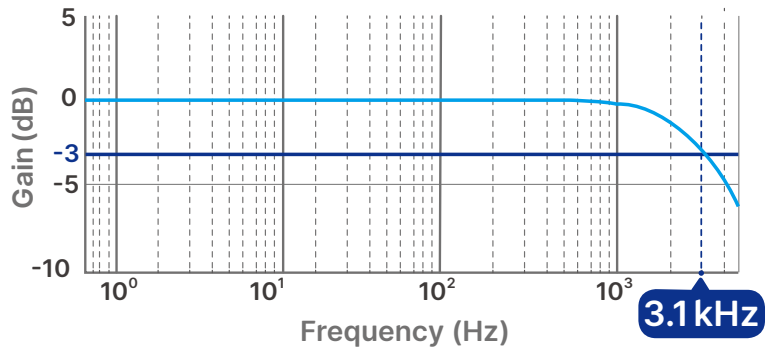

24-Bit Absolute Type Encoder

- The positioning precision is enhanced by the 16,777,216 pulses/turn encoder
- Reduced speed variance in low speed improves performance
- Absolute type encoder keeps motor's position when power is off

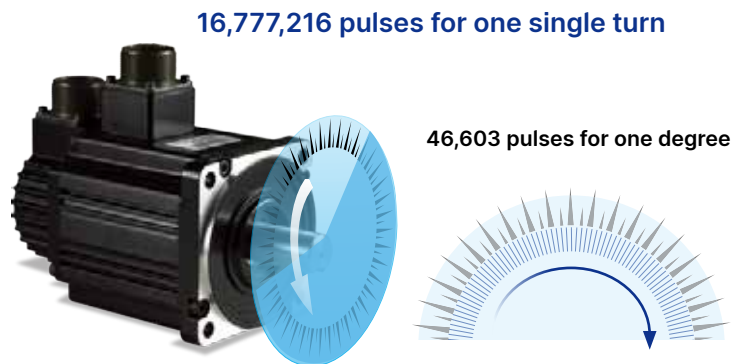

6,000 r/min and 350% Peak Torque Motor

- Motor speed increases by 1,000 r/min*, reducing motion time and increasing productivity
*Frame Size 60mm, 80mm and compared to the A2 Series
- Overload torque increases to 350% for faster start-up acceleration

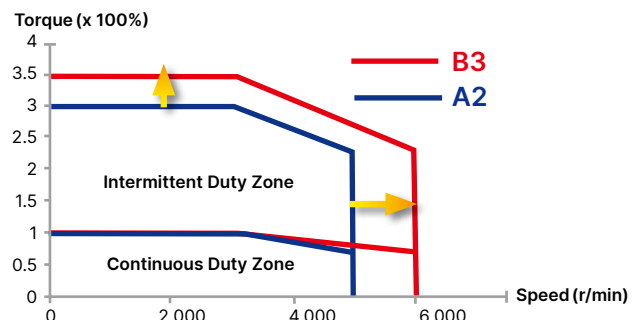
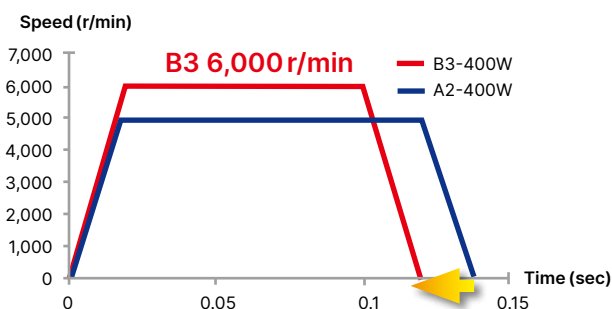

High Performance

High & Low Inertia Rotor Motors

- High-Inertia Motors: Ideal for equipment requiring high speed stability and resistance to external impact (e.g., machine tools)
- Low-Inertia Motors: Suitable for high-speed positioning and rapid reciprocating motion (e.g., electronic equipment)

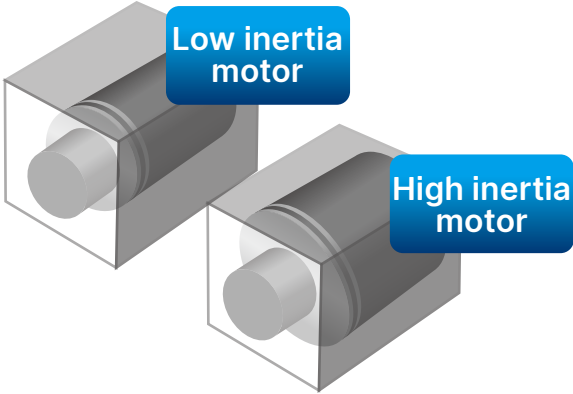

Low Cogging Torque Motor

- With a low cogging torque below 1.5%, it ensures smoother constant-speed operation and enhances stability in low-speed machining.

Cogging Torque (lower than 1.5%)

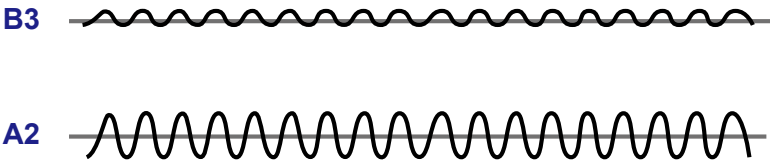

Motor Compatibility

- Supports A3 and B3 Series Motors

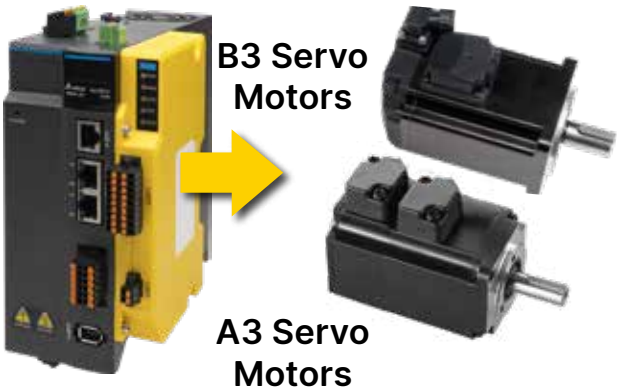

Full-Closed Loop Control

- Ensures positioning accuracy at the end and eliminates the effect of transmission backlash

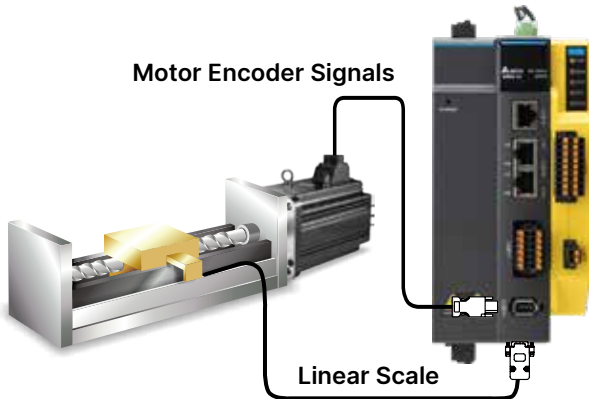

Multifunctional

Ethernet over EtherCAT (EoE)

- **Direct Ethernet Data Transmission:** Leverages EtherCAT's high-speed communication to transmit Ethernet data directly. Eliminates the need for intermediate protocol conversion to ensure **high real-time performance and transmission efficiency**.
- **Optimized for Multi-Axis Systems:** Enables direct access to data from multiple axes through the controller without the need of handling information separately, which significantly improves operational efficiency

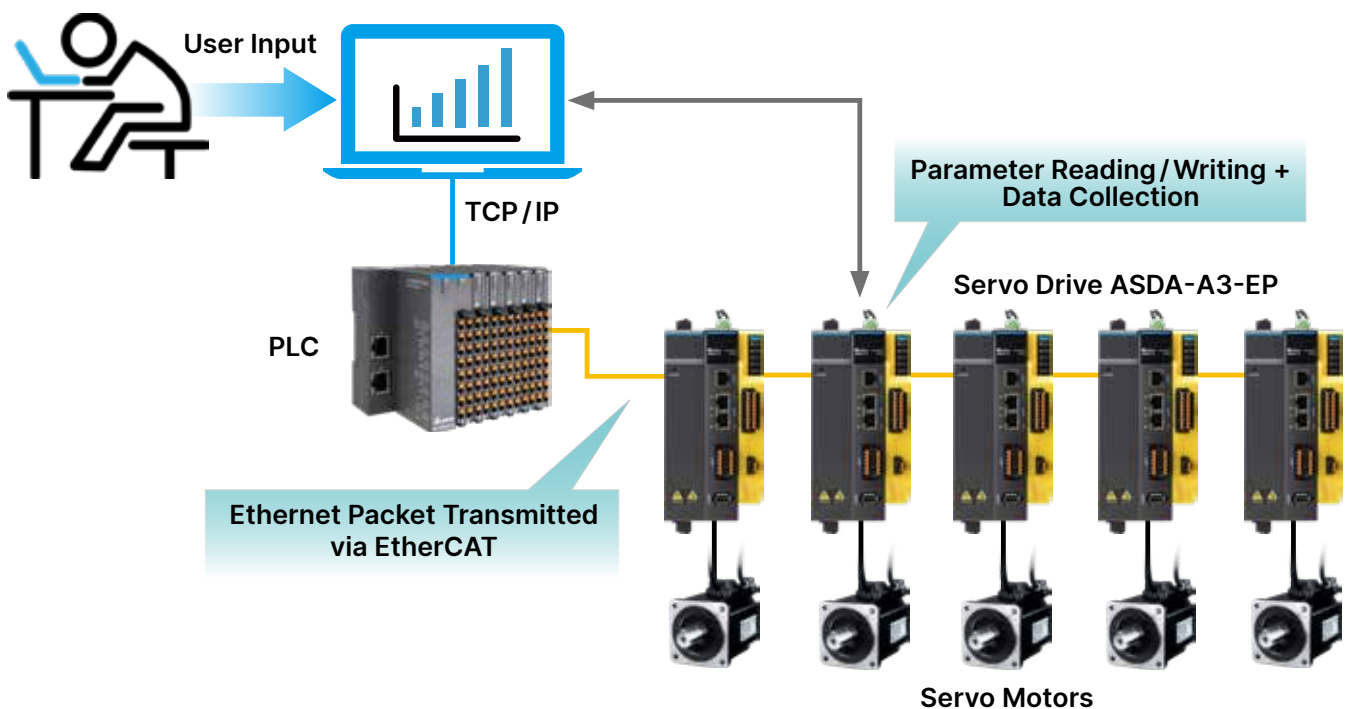

File Access over EtherCAT (FoE)

- FoE operates on the EtherCAT communication protocol's application layer, which allows reading and writing files between the master and slave devices
- FoE simplifies firmware updates as it eliminates the need for separate tools or systems. Version management across devices is more convenient with FoE

System Diagnosis

- Diagnose mechanical stiffness and damping coefficient by digitizing mechanical characteristics.
- Ensure consistent assembly quality with data of mechanical characteristics
- By comparing the data from different time span, the wear condition of a machine can be acquired

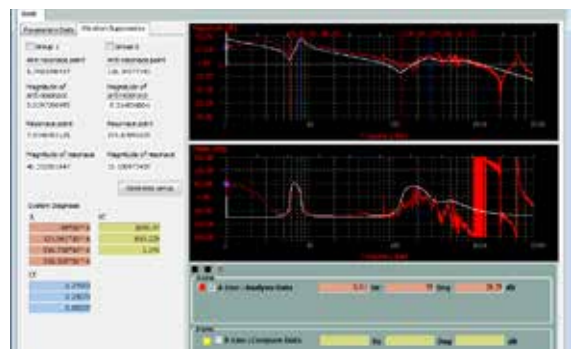

Multifunctional

Vibration Elimination

- New algorithm and intuitive UI allow fast and easy adjustment of low-rigidity structure
- Supports 2 sets of elimination algorithm and 2 sets of low frequency vibration suppression commands
- The vibration can be eliminated without slowing down its response

Without Vibration Suppression

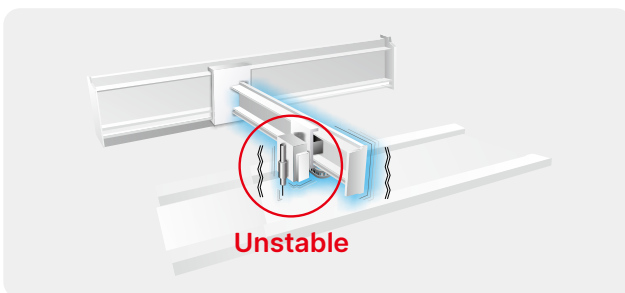

Delta Vibration Suppression

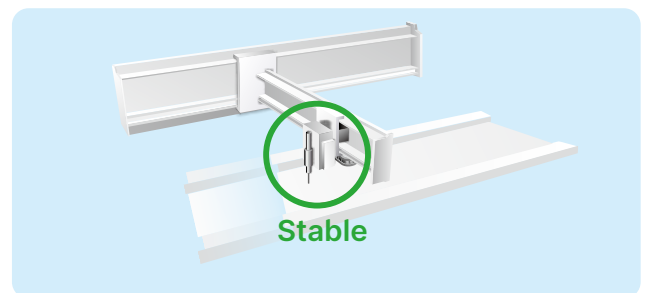

Automatic Gain Tuning

- New algorithm optimizes machine status
- Supports panel keypad and software auto-tuning
- The servo gains can be easily fine-tuned for better performance with its well-designed tuning modes

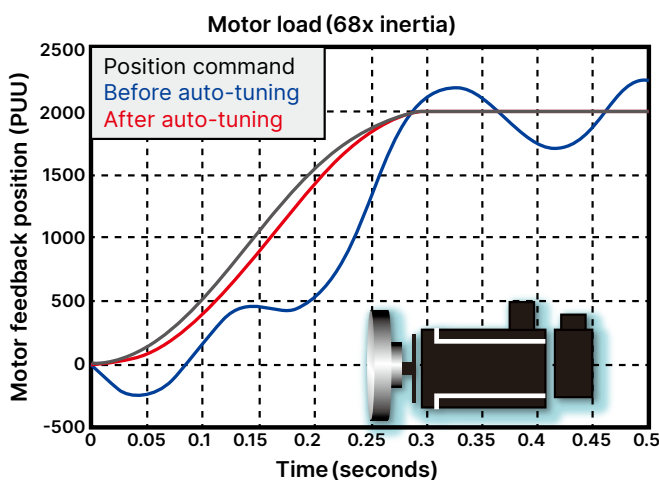

Multifunctional

Advanced Notch Filters

- 5 sets of notch filters with tunable bandwidth
- Filtering frequency up to 5,000Hz
- Simple settings to automatically eliminate resonance, which increases testing efficiency
- Shorter search time for resonance reduces impacts on the machine

Test Mechanism Illustration

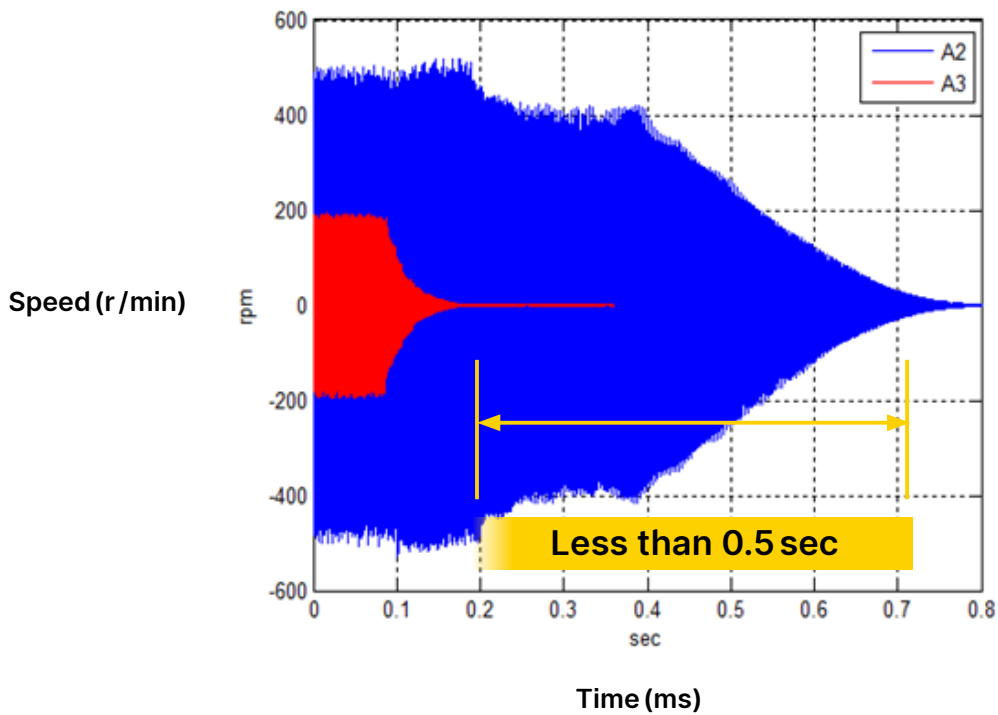
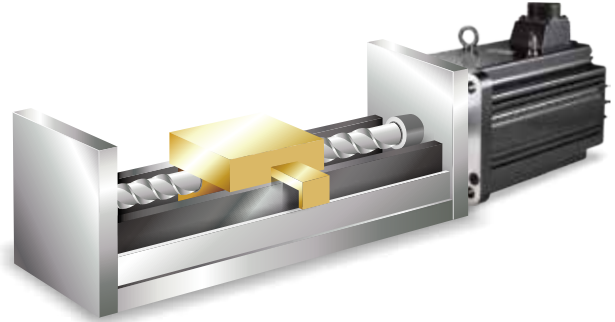

Built-in Motion Control

Touch Probe

- High-speed pulse capture
- High-speed DI captures instant position within 5 μ s of response time

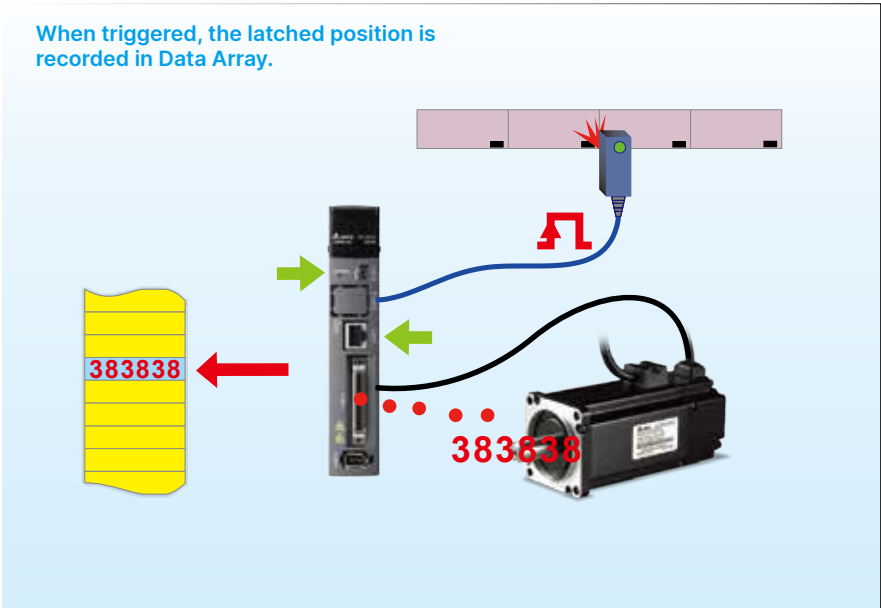

Energy-Saving and Compact Size

DC-Bus Sharing

- Allows shared usage of regenerative energy between A3 servo drives
- Multiple servo drives share DC Bus to reduce the need of braking resistors

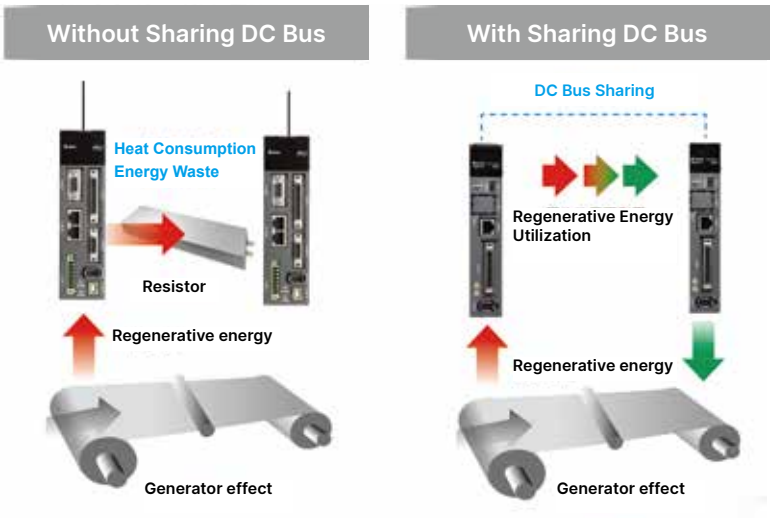

Energy-Saving and Compact Size

Slim Servo Drives

- 20% smaller to optimize space efficiency compared to ASDA-A2 Series

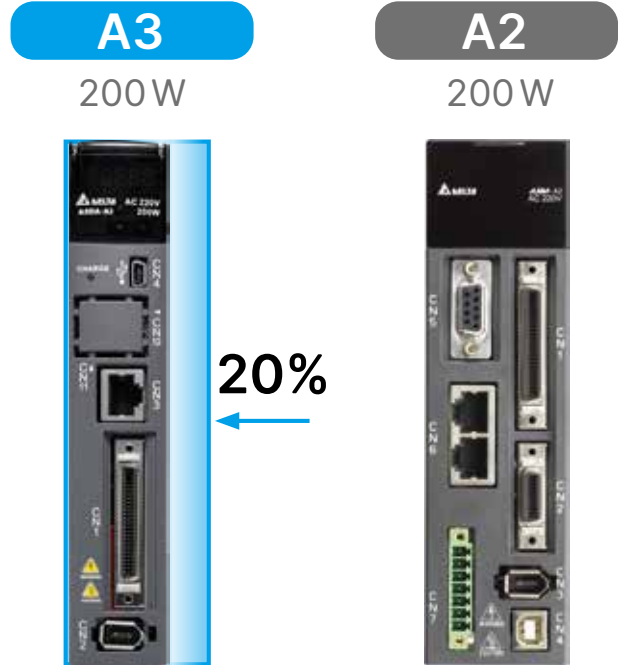

Compact Servo Motor

- 20% shorter than the ASDA-A2 Series motors
- Reduces overall weight when mounted on a motion mechanism

Shorter motor length (without oil seal)

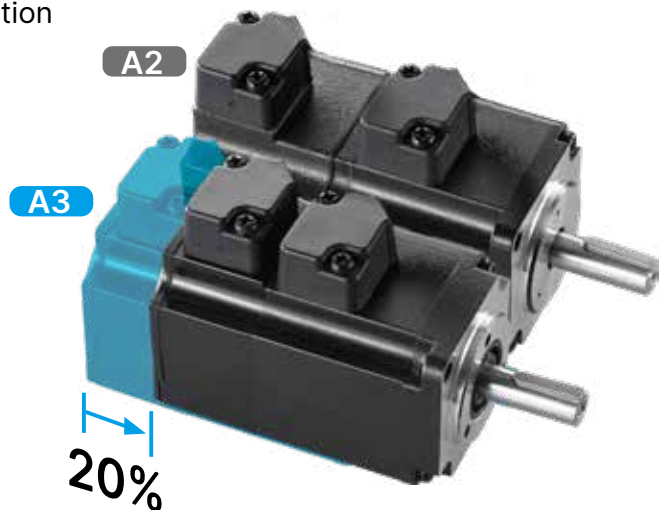

User-Friendly Software

Tree-View Index Window

- Well-organized list and collapsible menu help to access functions easily

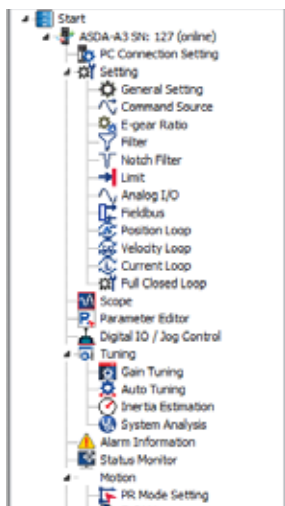

Graphical Interface for Parameter Settings

- Intuitive user interface for easy setups and parameter settings

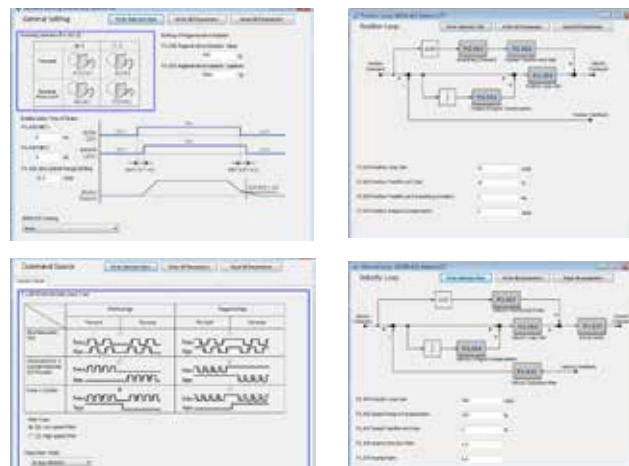

Automatic Gain Tuning Wizard

- Step-by-step guidance for servo system gain tuning

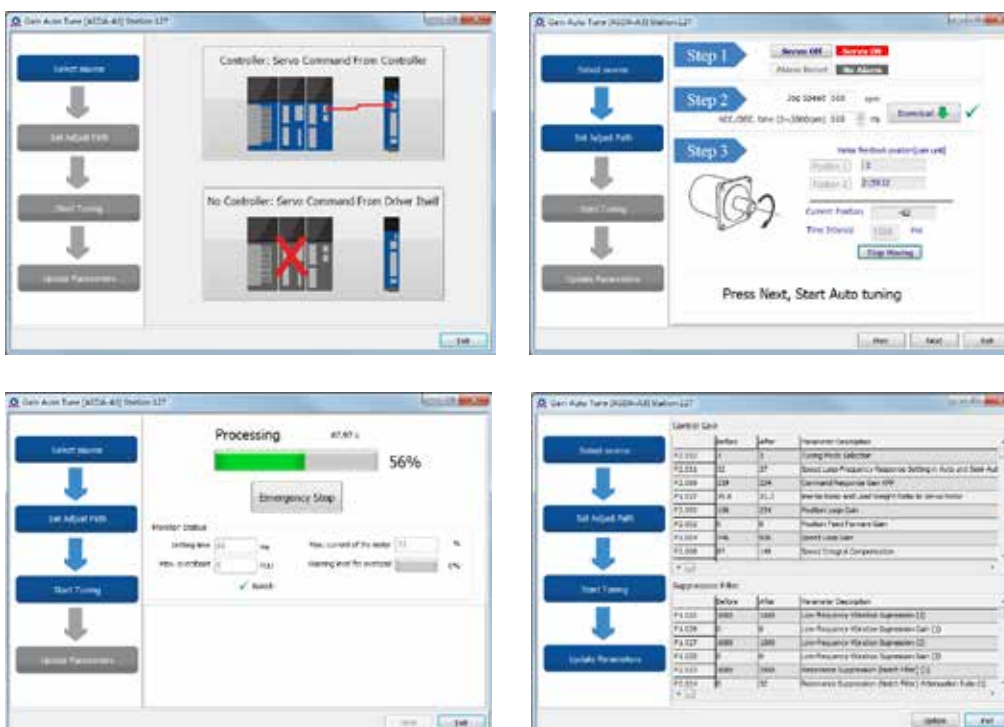

User-Friendly Software

System Analysis in Bode Plots

- Speed Open-Loop Mode**
 Tracks the optimization level of the system with bode plots for enhanced performance

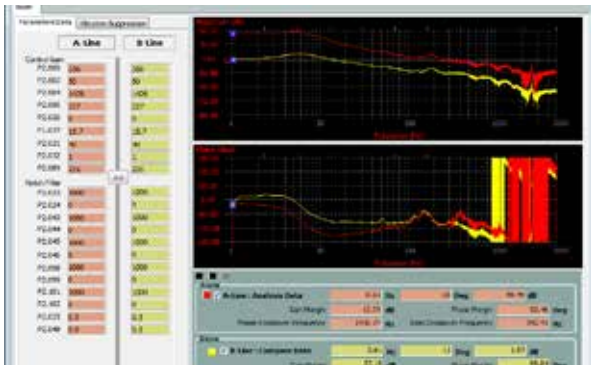

- System Module Mode**
 The machine rigidity can be identified from the bode plot in this mode

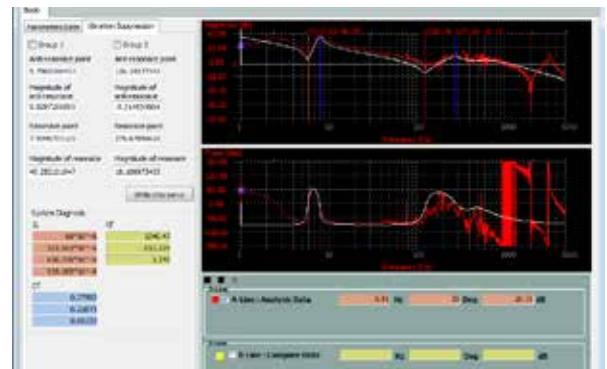

Oscilloscope

- Max. 8 channels with 16-bit data size, 10 kHz sampling rate**
- High-resolution 4 channels with 32-bit data size and 10 kHz sampling rate**
- High-sampling 4 channels with 16 bit data size and 20 kHz sampling rate**
- Analyzes spectrum and calculates RMS by simply selecting certain period of signals**
- Action and trigger conditions can be configured to collect data**

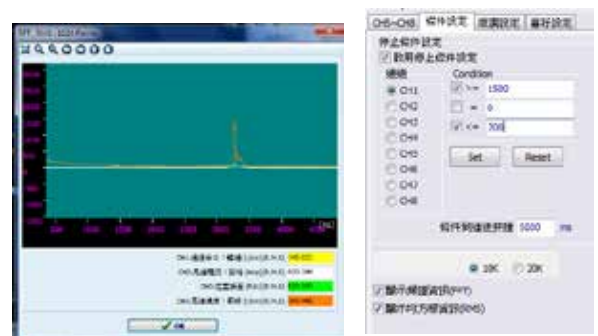

Delta Drive Safety

- Visual interface enables more intuitive safety feature configuration**

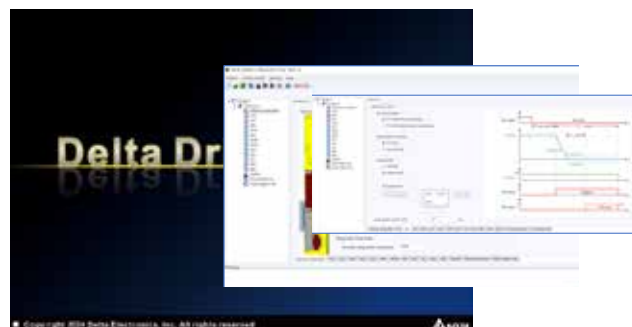

Product Information

Part Names and Functions

● STO (Safe Torque Off)

*Note: STO function is applicable to -M/-E models

- STO switch
- Connect to safety switch

● Main Circuit Input Terminal (R,S,T)

- R, S, T are used to connect to main circuit of the servo drive
- For 400W~15KW Servo Drives: Connects to 380-480V (+-10%) 3-phase power supply

● Control Circuit Input Terminal (L1c, L2c)

- L1c and L2c are used to connect DC 24V +-10 single-phase power supply

● PC Connection Port (CN4)

- Connects PCs or notebooks for operating ASDA-SOFT software
- Ethernet-based

● EtherCAT Communication Port Connector (CN6)

- EtherCAT communication control

● I/O Connector (CN1)

- Connects Delta's PLC products or other NC controllers

● Encoder Connector (CN2)

- Connects connect the encoder of the servo motor

● Safety Module Input / Output (CN12)

● Electromagnetic Brake Power Output (CN13)



● Safety Module Extension

● LED Signal



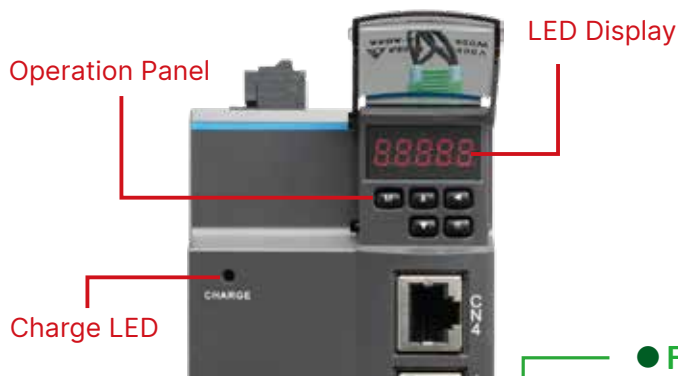

● Full-Closed Loop Control Terminal (CN5)

- Connects external linear scale or encoder for full-closed loop control

● Servo Motor Output (U, V, W)

- Connect servo motor terminal U, V, W. Never connect to main circuit power as the AC drive may be damaged beyond repair if connected to wrong cables

● Braking Resistor Terminal (P3, D C)

- Adopt internal resistor: Ensure the circuit is closed between P3 and D, and open between P3 and C (Note: Please refer to table of regenerative resistor specifications for the models with a built-in regenerative resistor from ASDA-A3 User Manual Chapter 2 Selecting Regenerative Resistors)
- Adopt external resistor: Connect it to P3 and C, and ensure an open circuit between P3 and D
- When using an external braking unit, connect it to P3、⊖ and ensure an open circuit between P3 and D, P3 and C

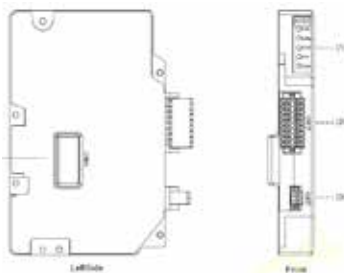

● Motors for Functional Safety

Frame Size	Model	Encoder Type
400 mm ~ 100 mm	ECM-B3□ - □2□□□□□□□□	2, A, B
	ECM-B3□ - □A□□□□□□□□	
	ECM-B3□ - □B□□□□□□□□	
130 mm	ECM-B3□ - □A□□□□□□□□	2, A, B
	ECM-B3□ - □B□□□□□□□□	
180 mm	Rated Output 2~5.5 kW ECM-B3□ - □A□□□□□□□□	2, A, B
	Rated Output 7.5 kW ECM-B3□ - □A□□□□□□□□	
220 mm	ECM-B3□ - □A□□□□□□□□	A

Number	Name	Description
(1) LED	PWR	Power light for Functional Safety Module
	Safety	Functional Safety Operating Light
	STAT	Functional Safety Module Status Light
	STO	STO Status Indicator Light
	FSoE	FSoE Status Indicator
(2) CN12	Safety Input/Output Connector	
(3) CN13	Electromagnetic Brake Power Output	
(4) CN9A	Servo Drive Connector	

Product Information

Optional Accessories

● Encoder Cables

- 3 m, 5 m, 10 m and 20 m standard cables available*^{A3 Series}
- Independent connector accessories possible on demand



● Power Cables

- 3 m, 5 m, 10 m and 20 m standard cables available*^{A3 Series}
- Independent connector accessories possible on demand
- Available in two types: with/without brake.



● Regenerative Resistor

- Refer to Chapter 2.8 of the ASDA-A3-EP User Manual for model selection



● Quick Connectors

- For 100W to 1.5kW servo drives
- Operating lever available for easy wiring



Product Information

ASDA-Soft Configuration Software

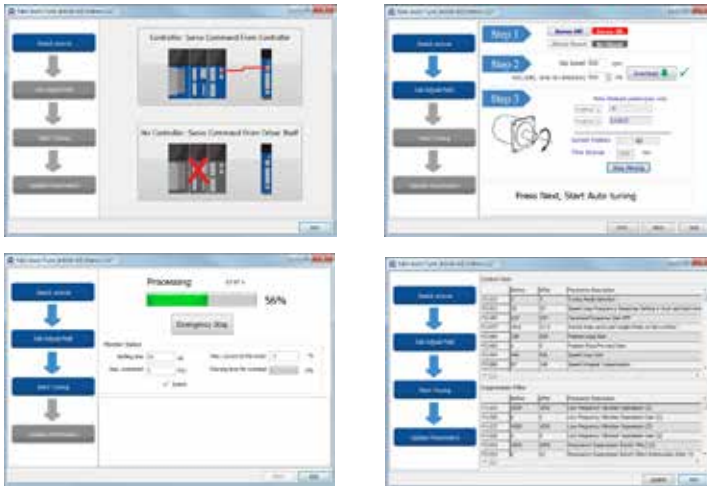

Auto-Tuning

- Step-to-step instructions
- Supports external commands and internal point-to-point commands
- Flow chart of the setting procedure and tuning progress
- Compare the tuning results (before & after)
- Downloadable gain parameters

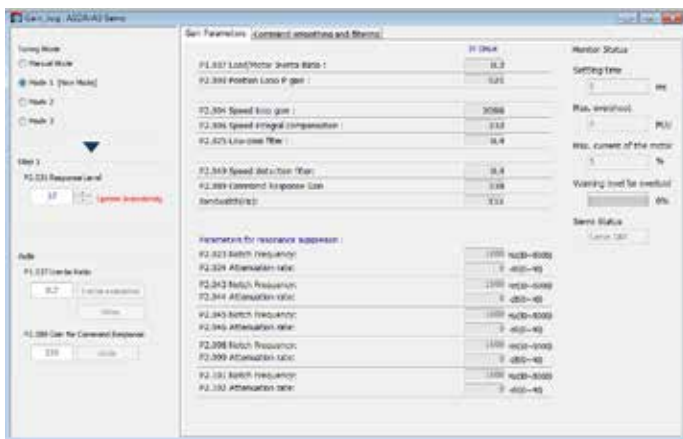

Advanced Tuning

Four advanced tuning modes:

- Manual mode: All gains tuned manually, ideal for experienced users
- Mode 1: For fine-tuning the bandwidth response level
- Mode 2: For fine-tuning the inertia and bandwidth response level
- Mode 3: For fine-tuning the inertia, bandwidth response level and command responsiveness

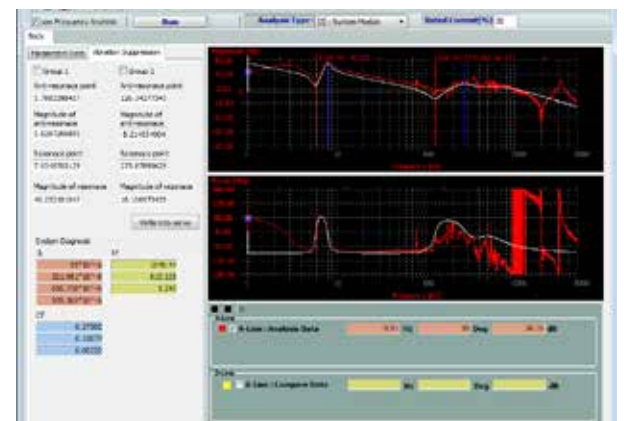

System Module and Low Frequency Analysis

- Analyze system rigidity
- Acquire the low-frequency resonance data and automatically set the relevant parameters to eliminate the vibration
- Collect data such as inertia, elasticity and viscous friction coefficient indicating the mechanism's features and wear condition



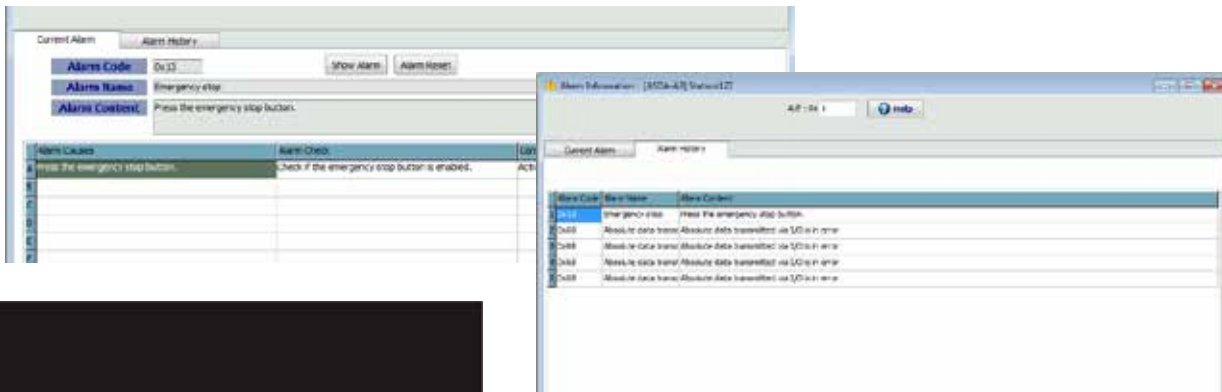

Alarm Information

- Display current alarm and alarm log
- Provide simple corrective actions for quick troubleshooting

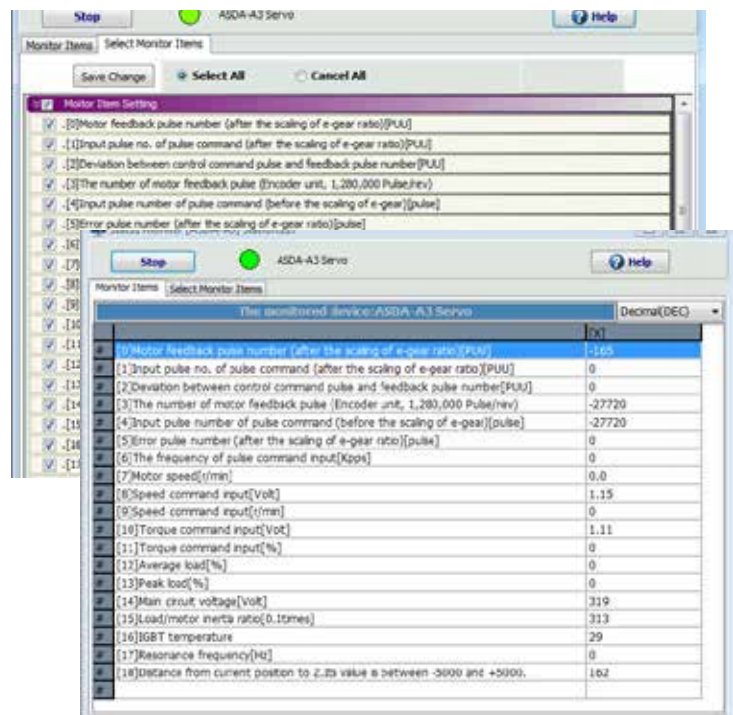

Condition Monitoring

- Real-time display of servo motor operation status via the monitoring list



Speed Open-Loop Mode

- Determine if the current system is the most optimized and thus improves the design
- Comparing between before-tuned and after-tuned control bandwidth to see the Gain Margin and Phase Margin differences.

Ordering Information

Servo System Combination Table (400V)

Motor Frame Size 60~220						Drive		Power	
Frame Size	Output (W)	Model Name	Rotational Inertia (x10 ⁻⁴ kg.m ²)	Rated / Max. Speed (rpm)	Rated / Max. Current (A)	Model Name	Frame Size	Standard	
			Standard / With Brake						
60	400	ECM-B3M-J ② 0604RB1	0.254/0.264	3000/6000	1.35/5.2	ASD-A3①-0443-EP	Frame A: 65 mm x 204 mm x 180.2 mm	ACS3-AFPWSAXX ACS3-ABPWSAXX	
		ECM-B3M-J ② 0604SB1							
80	750	ECM-B3M-J ② 0807RB1	1.07/1.13	3000/6000	2.15/7.9	ASD-A3①-0743-EP			
		ECM-B3M-J ② 0807SB1							
100	1000	ECM-B3M-J ② 1010RS1	2.78/3.06	3000/6000	3.03/9.21	ASD-A3①-0743-EP			
		ECM-B3M-J ② 1010SS1							
	1500	ECM-B3M-J ② 1015RS1	3.69/3.97	3000/6000	3.73/11.4	ASD-A3①-1543-EP			
		ECM-B3M-J ② 1015SS1							
	2000	ECM-B3M-J ② 1020RS1	4.68/4.95	3000/6000	5/15.3	ASD-A3①-1543-EP			
		ECM-B3M-J ② 1020SS1							
130	850	ECM-B3H-L ② 1308RS1	12.44/12.62	1500/4000	3.35/10	ASD-A3①-1043-EP	ACS3-CAPWA2XX ACS3-CRPWA2XX		
		ECM-B3H-L ② 1308SS1							
	1000	ECM-B3M-K ② 1310RS1	7.79/7.94	2000/3000	3/9.95	ASD-A3①-1043-EP			
		ECM-B3M-K ② 1310SS1							
	1300	ECM-B3H-L ② 1313RS1	18/18.14	1500/4000	3.85/12	ASD-A3①-1543-EP			
		ECM-B3H-L ② 1313SS1							
	1500	ECM-B3M-K ② 1315RS1	11.22/11.37	2000/3000	4.09/13.37	ASD-A3①-1543-EP			
		ECM-B3M-K ② 1315SS1							
	180	1800	ECM-B3H-L ② 1318RS1	22.6/22.8	1500/4000	5.75/18.1	ASD-A3①-2043-EP	Frame B: 110 mm x 200.8 mm x 260 mm	ACS3-CAPWC3XX ACS3-CRPWC3XX
			ECM-B3H-L ② 1318SS1						
		2000	ECM-B3M-K ② 1320RS1	14.65/14.8	2000/3000	5.3/17.1	ASD-A3①-2043-EP		
			ECM-B3M-K ② 1320SS1						
2000		ECM-B3M-K ② 1820RS1	29.11/30.38	2000/3000	5.7/18.1	ASD-A3①-2043-EP			
		ECM-B3M-K ② 1820SS1							
3000	ECM-B3M-L ② 1830RS1	53.63/54.9	1500/3000	9.1/29.45	ASD-A3①-3043-EP				
	ECM-B3M-L ② 1830SS1								
180	4500	ECM-B3M-L ② 1845RS1	67.73/69.15	1500/4000	13.3/35.35	ASD-A3①-4543-EP	ACS3-CAPWC4XX ACS3-CRPWC4XX		
		ECM-B3M-L ② 1845SS1							
	5500	ECM-B3M-L ② 1855R31	98.88/100.1	1500/4000	15.3/49.29	ASD-A3①-5543-EP			
		ECM-B3M-L ② 1855S31							
220	7500	ECM-B3M-L ② 1875R31	134.95/136.24	1500/4000	22.1/56.68	ASD-A3①-7543-EP	Frame C: 120 mm x 206 mm x 273 mm	ACS3-CAPWE6XX ACS3-CRPWE6XX	
		ECM-B3M-L ② 1875S31							
220	11000	ECM-B3M-L ② 221BR31	302.2/303.1	1500/4000	21.2/56.5	ASD-A3①-1B43-EP	Frame D: 141 mm x 225.5 mm x 312 mm		
		ECM-B3M-L ② 221BS31							
	15000	ECM-B3M-L ② 221FRS1	400/400.09	1500/4000	29.2/77	ASD-A3①-1F43-EP			
		ECM-B3M-L ② 221FSS1							

Notes:

- 1.Cable model name: The "XX" stands for cable length. 03 = 3 m, 05 = 5 m, 10 = 10 m, 20 = 20 m
- 2.Servo motor model name: 2 = encoder type
- 3.Servo drive model name: 1 = product series, 2 = model code.
- 4.Cables are divided into standard, torsion-resistant, angle connector.
For details, please refer to the ordering information.

Connector & Cable						
Cable	Power Cable with Brake		Incremental type / Battery-free type		Absolute Encoder Cable	
Torsion-Resistant	Standard	Torsion-Resistant	Standard	Torsion-Resistant	Standard	Torsion-Resistant
ACS3-AFPRSAXX ACS3-ABPRSAXX	ACS3-AFPWSBXX ACS3-ABPWSBXX	ACS3-AFPRSBXX ACS3-ABPRSBXX	ACS3-AFEASIXX ACS3-ABEASIXX ACS3-AFEASIOX ACS3-ABEASIOX	ACS3-AFERSIXX ACS3-ABERSIXX ACS3-AFERSIOX ACS3-ABERSIOX	ACS3-AFEASAXX ACS3-ABEASAXX ACS3-AFEASAOX ACS3-ABEASAOX	ACS3-AFERSAXX ACS3-ABERSAXX ACS3-AFERSAOX ACS3-ABERSAOX
ACS3-CAPFA2XX ACS3-CRPFA2XX	ACS3-CABRA1XX ACS3-CRBRA1XX	ACS3-CABFA1XX ACS3-CRBFA1XX	ACS3-CAENA1XX ACS3-CRENA1XX	ACS3-CAEFA1XX ACS3-CREFA1XX	ACS3-CAEAA1XX ACS3-CREAA1XX	ACS3-CAEBA1XX ACS3-CREBA1XX
ACS3-CAPFC3XX ACS3-CRPFC3XX						
ACS3-CAPFC4XX ACS3-CRPFC4XX						
ACS3-CAPFE6XX ACS3-CRPFE6XX						

Product Information

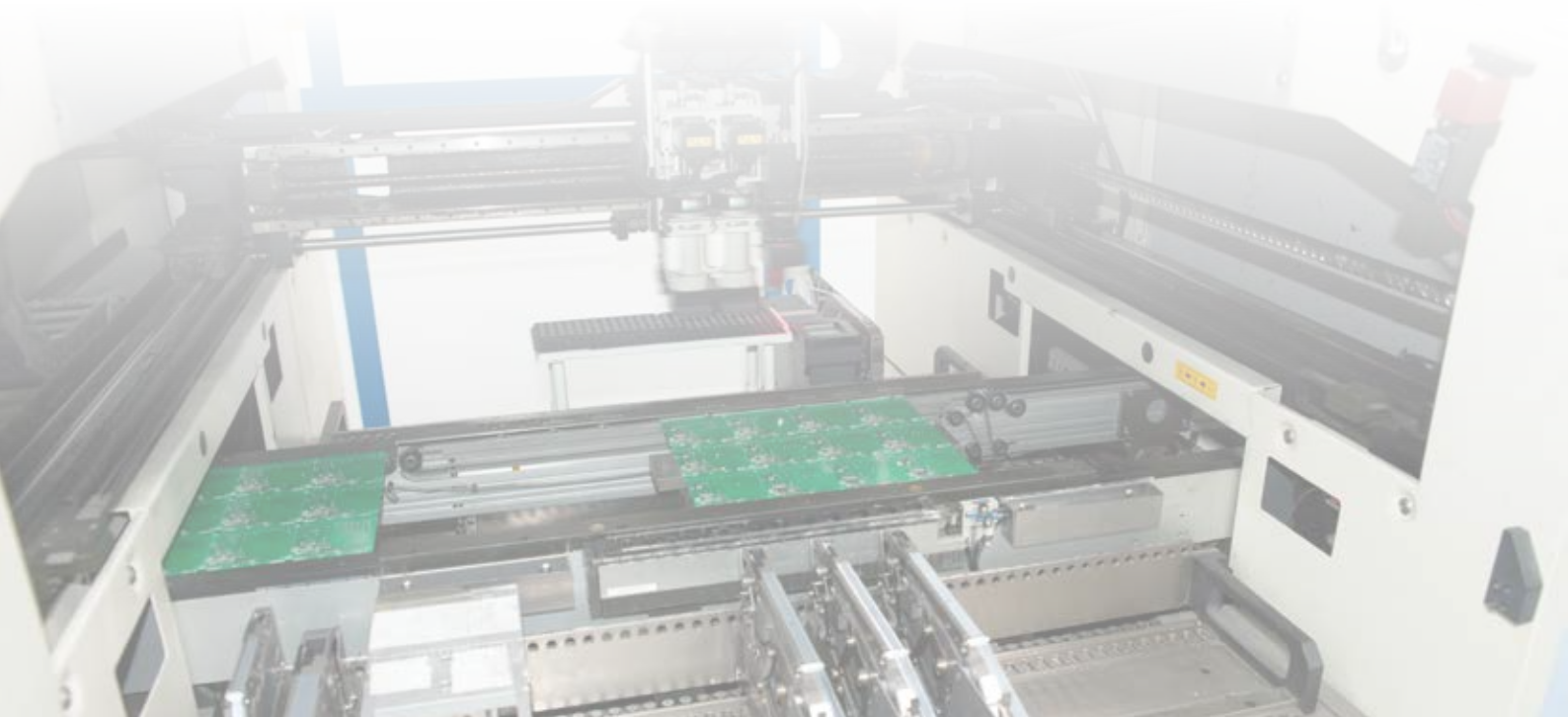
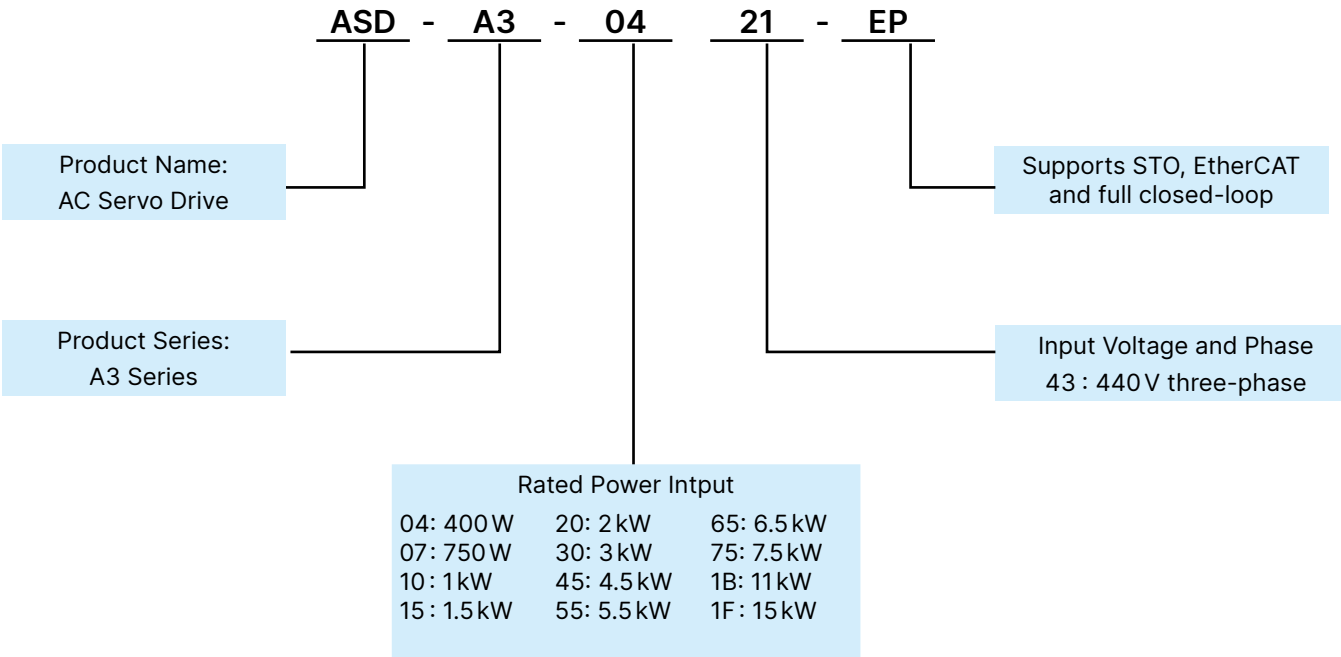

Model Description

ASDA-A3-EP Series AC Servo Drive



Ordering Information

Servo Drive Specifications 400 V



ASDA-A3		400W	750W	1kW	1.5kW	2kW	3kW
		0.4	0.75	1	1.5	2	3
Power Supply	Phase / Voltage	Three-phase 400VAC					
	Permissible Voltage	Three-phase 380 ~ 480 VAC , -10% ~ +10%					
	Input Current (3PH) (Unit: Arms)	0.9	1.8	2.4	3.4	4.5	6.3
	Input Current (1PH) (Unit: Arms)	1.7	1.7	1.7	1.7	2.1	2.1
	Continuous Output Current (Unit: Arms)	1.6	3.12	3.52	5.06	6.6	9.11
	Max. Instantaneous Output Current (Unit: Arms)	5.4	9.7	10.54	16.35	19.88	29.45
	Final Power Dissipation (W)	49	72	86	105	125	195
Cooling Method	Fan cooling						
Drive Resolution	24-bit (16,777,216 p/rev)						
Main Circuit Control	SVPW Mcontrol						
Tuning Mode	Auto/Manual						
Regenerative Resistor	No						
Control Mode Position	Smoothing Method	Low-pass and P-curve filters					
	E-Gear Ratio	E-Gear ratio: N / M times, limited to (1 / 4 < N / M < 262,144) N: 1 ~ 536,870,911/M: 1 ~ 2,147,483,647					
	Torque Limit	Parameter settings					
	Feed Forward Compensation	Parameter settings					
Speed Control Mode	Analog Command Input (Non-DMCNET mode only)	Voltag Range	0 ~ ±10 V _{DC}				
		Resolution	15-bit				
		Input Impedance	1MΩ				
		Time Constant	25 μs				
	Speed Control Range ^{*1}	1 : 6,000					
	Smoothing Method	Low-pass and S-curve filters					
	Torque Limit	Parameter settings or analog input (Non-DMCNET mode only)					
Bandwidth	Maximum 3.1kHz						
	±0.01% at 0% to 100% load fluctuation						
	±0.01% at ±10% power fluctuation						
Speed Calibration Ratio ^{*2}	±0.01% at 0°C to 50°C ambient temperature fluctuation						
Control Mode Torque	Analog Command Input (DMCNET mode only)	Voltag Range	0 ~ ±10 V _{DC}				
		Input Impedance	1MΩ				
		Time Constant	25 μs				
	Smoothing Method	Low-pass filter					
Analog Monitor Output	Monitoring signal can be set with parameters (voltage output range: ±8V); resolution: 10-bit						
Digital I/O	Input	L, M : 10 Inputs; F, E: 4 DI Inputs. Refer to Ch. 8 of Manual for function settings.					
	Output	L, M : 6 outputs; F, E: 2 DO outputs. Refer to Ch. 8 of Manual for function settings.					
Protection Function	Overcurrent, Overvoltage, Undervoltage, Overheat, Regeneration error, Overload, Excessive speed deviation, Excessive position deviation, Encoder error, Adjustment error, Emergency stop, Forward / reverse limit error, Serial communication error, RST leak phase, Serial communication timeout, Short-circuit protection for terminals U, V, W						
Communication Interface	RS-485 / USB / CANopen / DMCNET / Ethernet / EtherCAT						
Environment	Installation Site	Indoors (avoid direct sunlight), no corrosive vapor (avoid fumes, flammable gases, and dust)					
	Altitude	Altitude 2,000 m or lower above sea level					
	Atmospheric Pressure	86 kPa ~ 106 kPa					
	Operating Temperature	0 °C ~ 55 °C (If operating temperature is above 45°C, forced cooling is required)					
	Storage Temperature	-20 °C ~ 65 °C					
	Humidity	0 to 90 % RH (non-condensing)					
	Vibration	10 Hz ~ 57 Hz: 0.075 mm amplitude ; 58 Hz ~ 150 Hz: 1 G					
	IP Rating	IP20					
	Power System	TN system ^{*3*4}					
Certifications	IEC / EN / UL 61,800-5-1  						

Notes:

- *1. Within the rated load, the speed ratio is: the minimum speed (smooth operation) / rated speed.
- *2. When the command is at the rated speed, the speed regulation rate is defined as: (No-load speed - Full-load speed) / Rated speed
- *3. TN system: the neutral point of the power system connects directly to the ground.
The exposed metal components connect to the ground through the protective ground conductor
- *4. Use a single-phase three-wire power system for the single-phase power model.
- *5 To meet safety function requirements, please install the servo drive in a control cabinet with a protection rating of IP54 or higher.
- *6 According to EN 61,800-5-1:2007 / A1:2,017, this device does not include the following functions: Thermal memory for shutdown, Thermal memory for power loss, Speed-sensitive functionality

Ordering Information

Servo Drive Specifications 400 V

ASDA-A3		4.5kW	5.5kW	7.5kW	11kW	15kW
		4.5	5.5	7.5	11	W
Power Supply	Phase / Voltage	Three-phase 400 VAC				
	Permissible Voltage	Three-phase 380 ~ 480 VAC, -10% ~ +10%				
	Input Current (3PH) (Unit: Arms)	8.7	10.7	14.1	21.8	29.6
	Input Current (1PH) (Unit: Arms)	2.1	2.1	2.5	3	3
	Continuous Output Current (Unit: Arms)	13.3	15.34	22.4	27.3	31
	Max. Instantaneous Output Current (Unit: Arms)	35.35	49.29	56.68	68.25	80.2
	Final Power Dissipation (W)	220	310	400	465	530
Cooling Method	Fan cooling					
Drive Resolution	24-bit (16777216 p/rev)					
Main Circuit Control	SVPWM control					
Tuning Mode	Auto/Manual					
Regenerative Resistor	No					
Position Control Mode	Smoothing Method	Low-pass and P-curve filters				
	E-Gear Ratio	E-Gear ratio: N / M times, limited to (1 / 4 < N / M < 262,144) N : 1 ~ 536,870,911 / M : 1 ~ 2,147,483,647				
	Torque Limit	Parameter settings				
	Feed Forward Compensation	Parameter settings				
Speed Control Mode	Analog Command Input (Non-DMCNET mode only)	Voltage Range	0 ~ ±10 V _{DC}			
		Resolution	15-bit			
		Input Impedance	1MΩ			
		Time Constant	25 μs			
	Speed Control Range *1	1 : 6,000				
	Smoothing Method	Low-pass and S-curve filters				
	Torque Limit	Parameter settings or analog input (Non-DMCNET mode only)				
Bandwidth	Maximum 3.1kHz					
	±0.01% at 0% to 100% load fluctuation					
	±0.01% at ±10% power fluctuation					
Speed Calibration Ratio *2	±0.01% at 0°C to 50°C ambient temperature fluctuation					
Torque Control Mode	Analog Command Input (DMCNET mode only)	Voltage Range	0 ~ ±10 V _{DC}			
		Input Impedance	1MΩ			
		Time Constant	25 μs			
	Smoothing Method	Low-pass filter				
Analog Monitor Output	Monitoring signal can be set with parameters (voltage output range: ±8V); resolution: 10-bit					
Digital I/O	Input	L, M : 10 Inputs; F, E : 4 DI Inputs. Refer to Ch. 8 of Manual for function settings.				
	Output	L, M : 6 outputs; F, E : 2 DO outputs. Refer to Ch. 8 of Manual for function settings.				
Protection Function	Overcurrent, Overvoltage, Undervoltage, Overheat, Regeneration error, Overload, Excessive speed deviation, Excessive position deviation, Encoder error, Adjustment error, Emergency stop, Forward / reverse limit error, Serial communication error, RST leak phase, Serial communication timeout, Short-circuit protection for terminals U, V, W					
Communication Interface	RS-485 / USB / CANopen / DMCNET / Ethernet / EtherCAT					
Environment	Installation Site	Indoors (avoid direct sunlight), no corrosive vapor (avoid fumes, flammable gases, and dust)				
	Altitude	Altitude 2,000 m or lower above sea level				
	Atmospheric Pressure	86 kPa ~ 106 kPa				
	Operating Temperature	0 °C ~ 55 °C (If operating temperature is above 45°C, forced cooling is required)				
	Storage Temperature	-20 °C ~ 65 °C				
	Humidity	0 to 90% RH (non-condensing)				
	Vibration	10 Hz ~ 57 Hz: 0.075 mm amplitude ; 58 Hz ~ 150 Hz: 1G				
	IP Rating	IP20				
Power System	TN system *3+4					
Certifications	IEC/EN/UL 61800-5-1  					

Notes:

- *1. Within the rated load, the speed ratio is: the minimum speed (smooth operation) / rated speed.
- *2. When the command is at the rated speed, the speed regulation rate is defined as: (No-load speed - Full-load speed) / Rated speed
- *3. TN system: the neutral point of the power system connects directly to the ground. The exposed metal components connect to the ground through the protective ground conductor.
- *4. Use a single-phase three-wire power system for the single-phase power model.
- *5. To meet safety function requirements, please install the servo drive in a control cabinet with a protection rating of IP54 or higher.
- *6. According to EN 61800-5-1:2007/A1:2017, this device does not include the following functions: Thermal memory for shutdown, Thermal memory for power loss, Speed-sensitive functionality

Ordering Information

Safety Module Model Description

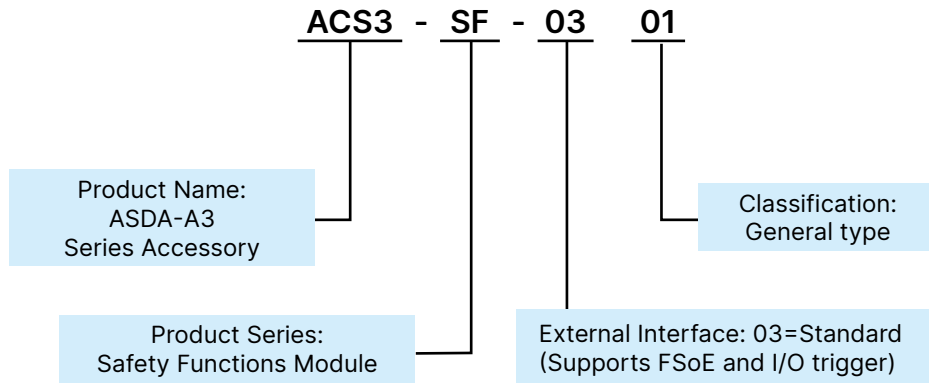

Safety Module Standard Specifications

Item		Certification standards	I/O Type		Communication	
HFT	Hardware fault tolerance	IEC/EN61508	1		1	
Type	Subsystem type	IEC/EN61508	Type B		Type B	
SIL	Safety integrity level	IEC/EN61508	SIL 3		SIL 3	
		IEC/EN62061	Maximum SIL 3		Maximum SIL 3	
PFH	Dangerous failure rate	IEC/EN62061	Refer to the table below.			
Response Time	Response time	IEC/EN61508	STO, SBC	10 ms	STO, SBC	15 ms
			Others	25 ms	Others	25 ms
Fault Reaction Time	Failure reaction time	IEC/EN61800-5-2	STO stop	10 ms	STO stop	10 ms
			SS1 stop	25 ms	SS1 stop	25 ms
Category	Category	EN ISO13849-1:2015	Type 3		Type 3	
PL	Performance level	EN ISO13849-1:2015	PL e		PL e	
MTTFd	Mean dangerous failure time	EN ISO13849-1:2015	High (≥ 100 years)		High (≥ 100 years)	
DC	Diagnostic range	EN ISO13849-1:2015	DC ≥ 98[%]		DC ≥ 98[%]	
Mission Time	Mission time	EN ISO13849-1:2015	20 years		20 years	

Dangerous Failure Rate (PFH) PFH varies by input type and safety functions.

Safety Functions	I/O Type	Communication Type
STO	PFH < 1.4 x 10 ⁻⁸ (1/h)	PFH < 1.5 x 10 ⁻⁸ (1/h)
SS1/SS2/SOS/SLS/SLI/SDI/SLP	PFH < 1.7 x 10 ⁻⁸ (1/h)	PFH < 1.8 x 10 ⁻⁸ (1/h)
SMS	PFH < 1.7 x 10 ⁻⁸ (1/h)	PFH < 1.7 x 10 ⁻⁸ (1/h)
SSM	PFH < 1.9 x 10 ⁻⁸ (1/h)	PFH < 1.8 x 10 ⁻⁸ (1/h)
SBC	PFH < 1.6 x 10 ⁻⁸ (1/h)	PFH < 1.6 x 10 ⁻⁸ (1/h)

Ordering Information

Servo Drive Dimensions - 400 V

Frame D

400W/750W/1kW/1.5kW

Weight

1.8 kg

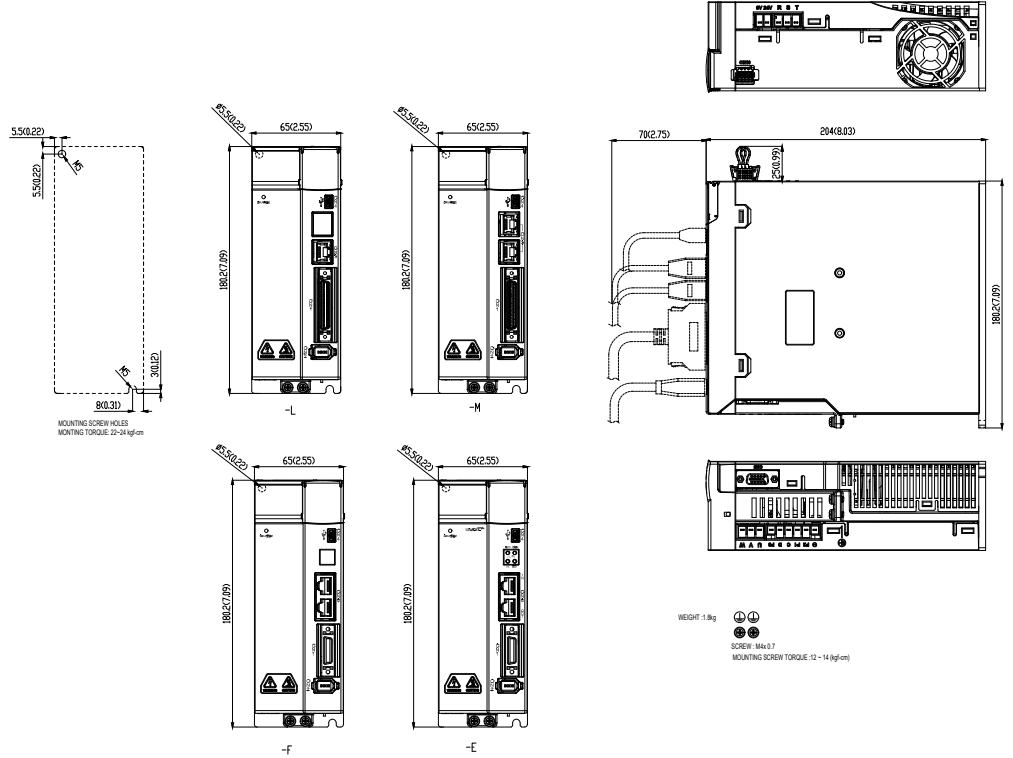

Frame E

2kW/3kW/5.5kW

Weight

2 kW/3 kW 3.45 kg

4.5 kW / 5.5 kW 4 kg

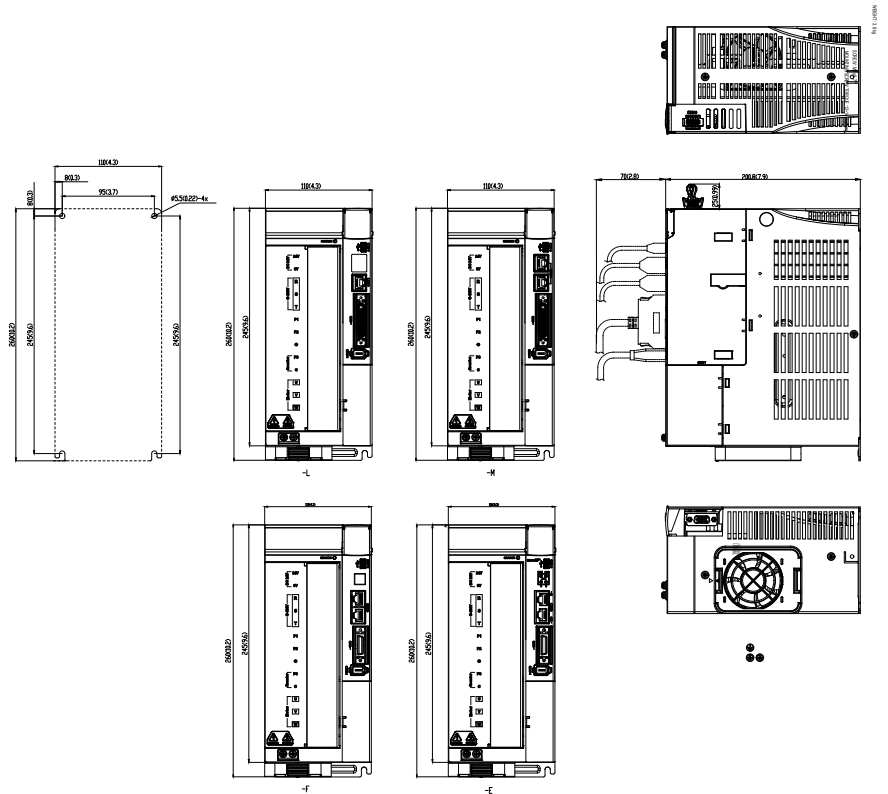

Ordering Information

Servo Drive Dimensions - 400 V

Frame F

6.5kW/7.5kW

Weight

5.5 kg

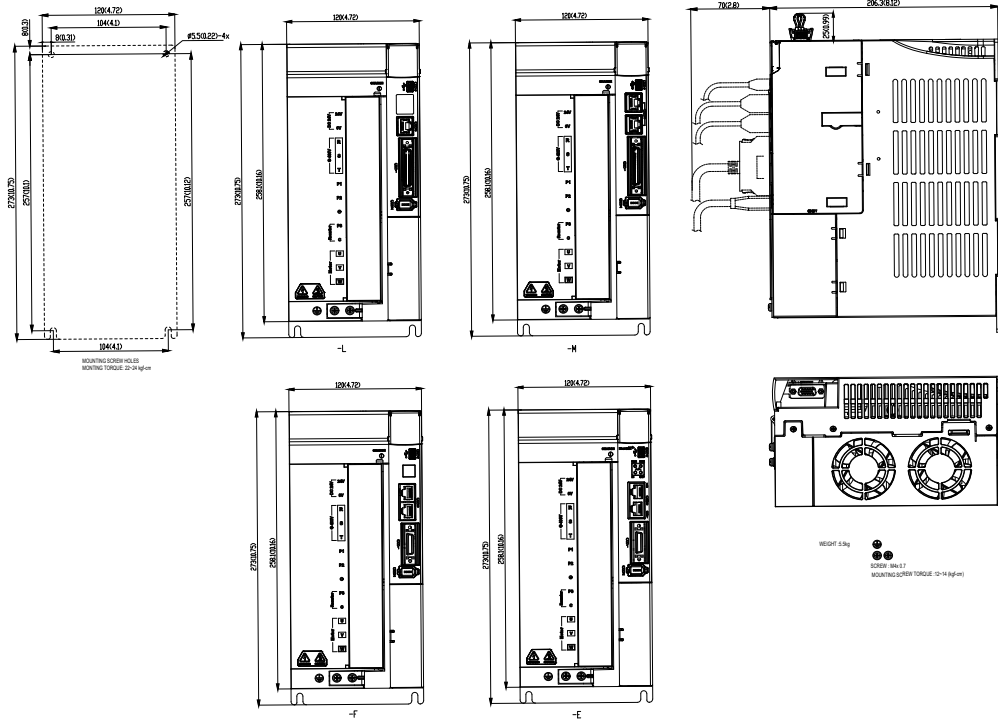

Frame G

11kW/15kW

Weight

7.5 kg

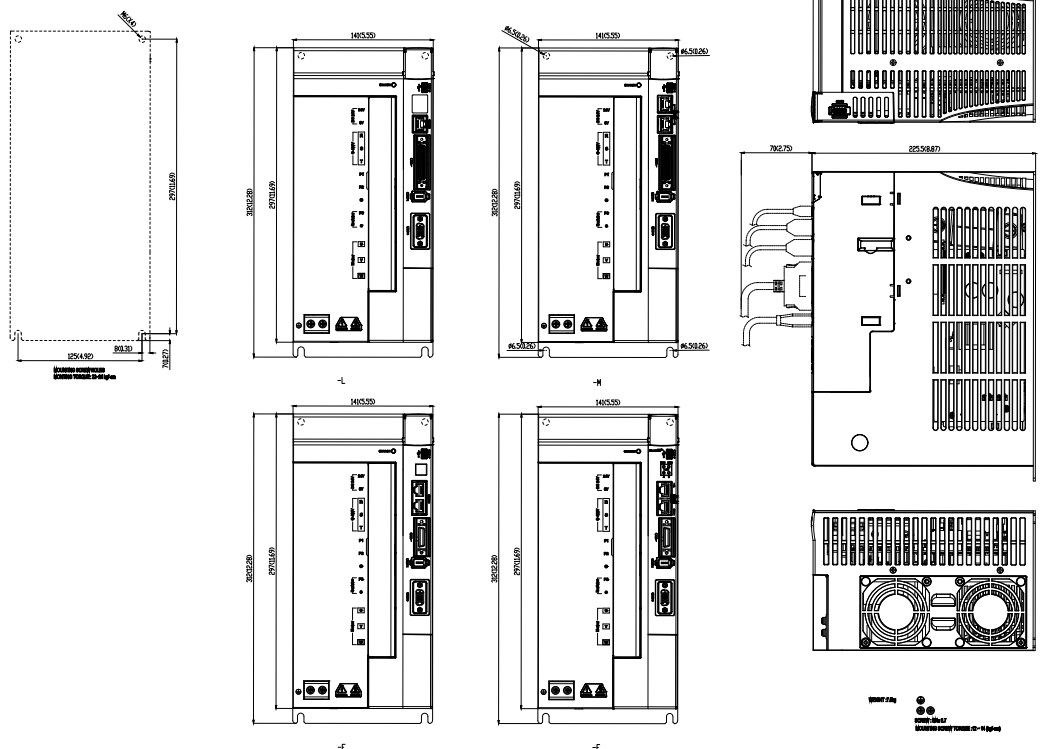

Ordering Information

Servo Motor Model Information ECM-B3 Series

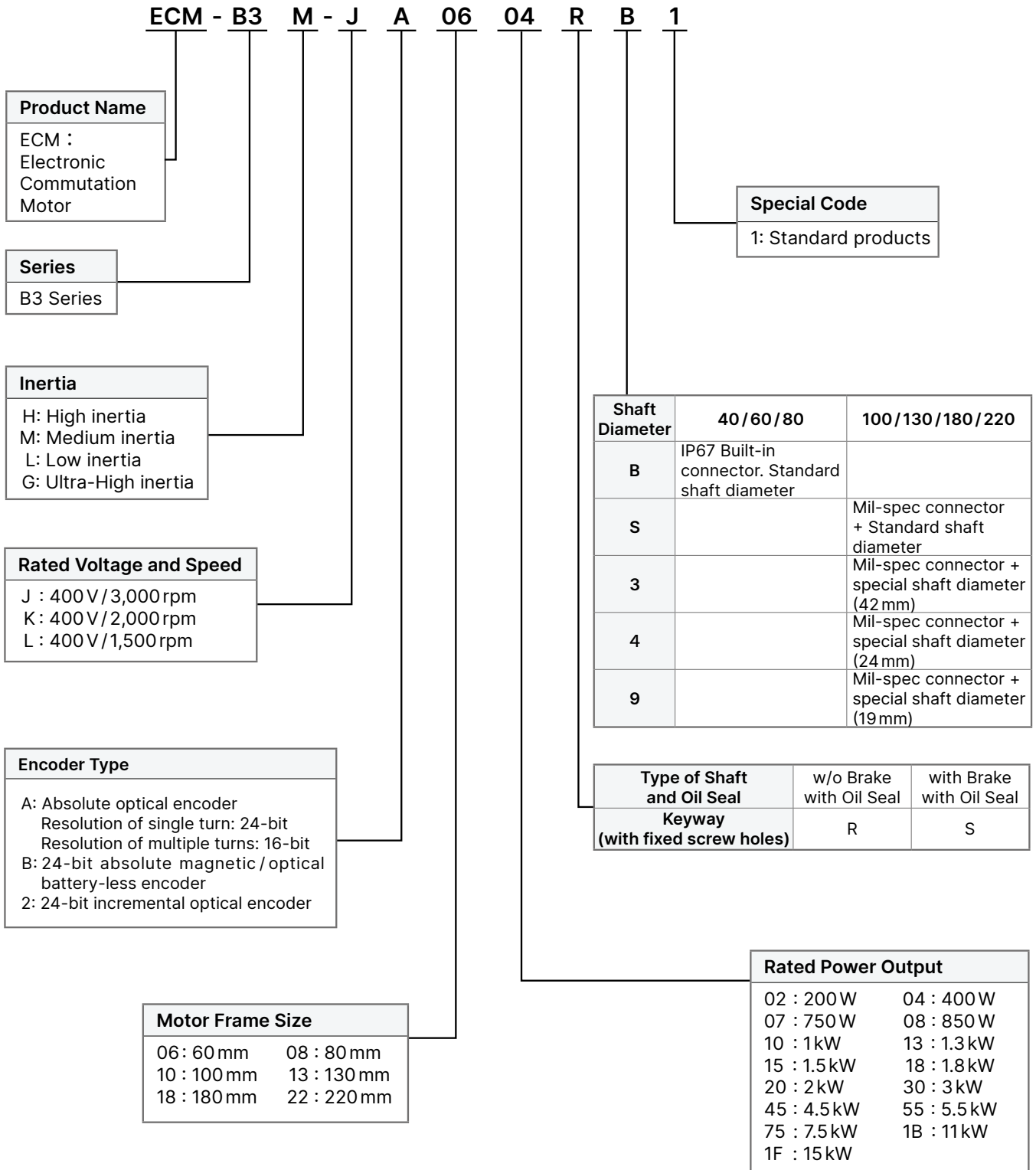

Ordering Information

ECM-B3M Series Servo Motor Specifications (400 V)

	ECM-B3M-J 0604	ECM-B3M-J 0807
Rated Power (kW)	0.4	0.75
Rated Torque (N-m) ^{*2}	1.27	2.4
Maximum Torque (N-m)	4.45	8.4
Rated Speed (rpm)	3,000	
Maximum Speed (rpm)	6,000	
Rated Current (Arms)	1.35	2.15
Max. Instantaneous Current (Arms)	5.20	7.90
Rated Power Rate (kW/s)	63.5	53.83
Rated Power Rate (kW/s) with brake	61.09	50.97
Rotor Inertia (×10 ⁻⁴ kg.m ²)	0.254	1.07
Rotor Inertia (×10 ⁻⁴ kg.m ²) with brake	0.264	1.13
Mechanical Time Constant (ms)	0.53	0.55
Mechanical Time Constant (ms) with brake	0.55	0.58
Torque Constant -KT (N-m/A)	0.94	1.12
Voltage Constant -KE (mV/(rpm))	34.66	40.34
Armature Resistance (Ohm)	6.47	2.20
Armature Inductance (mH)	20.6	11.2
Electrical Time Constant (ms)	3.18	5.09
Weight – without brake (kg)	1.2	2.34
Weight – with brake (kg)	1.6	3.15
Max. Radial Loading (N) ^{*5}	245	392
Max. Axial Loading (N) ^{*5}	74	147
Brake Working Voltage	24 V _{DC} ± 10%	
Brake Power Consumption (at 20°C)[W]	7.6	8.5
Brake Holding Torque [Nt-m (min)] ^{*3}	1.3	3.2
Brake Release Time [ms (Max)]	20	30
Brake Pull-In Time [ms (Max)]	50	60
Derating (%) (with oil seal)	5	5
Torque Feature (T-N Curve)		
Insulation Class	Class A (UL) , Class B (CE)	
Insulation Resistance	>100 MΩ , DC 500 V	
Insulation Strength	2.3k V _{AC} , 1sec	
Vibration Level (μm)	V15	
Operating Temperature	-20°C ~ 60°C*4	
Storage Temperature	-20°C ~ 80°C	
Storage & Operation Humidity	20 ~ 90% RH (non-condensing)	
Vibration Capacity	2.5 G	
IP Rating	IP67	
Certifications		

Notes:
 1. In the servo motor model name, 2 represents the encoder type
 2. If the motor frame temperature exceeds 90° C, please enhance heat dissipation (e.g., install a heat sink).
 The rated torque is the continuous permissible torque between 0 to 40°C operating temperature which is suitable for the servo motor mounted with the following heat sink dimensions.
 F100: 300 mm x 300 mm x 12 mm
 F130: 400 mm x 400 mm x 20 mm
 3. The built-in servo motor brake is only for keeping the object in a stopped state.
 4. If the operating temperature is over 40°C, refer to the power derating curves of B3 motors on page 37 on page 37.

5. Please follow the max. tolerant loading of the motor shaft end listed below during operation

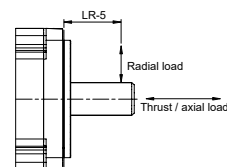

Ordering Information

ECM-B3H Series Servo Motor Specifications (400 V)

	ECM-B3H-L □ 1308	ECM-B3H-L □ 1313	ECM-B3H-L □ 1318
Rated Power (kW)	0.85	1.3	1.8
Rated Torque (N-m) ²	5.39	8.34	11.5
Maximum Torque (N-m)	16.17	25.02	34.5
Rated Speed (rpm)		1,500	
Maximum Speed (rpm)		4,000	
Rated Current (Arms)	3.35	3.85	5.75
Max. Instantaneous Current (Arms)	10.0	12.0	18.1
Rated Power Rate (kW/s)	23.4	38.6	58.5
Rated Power Rate (kW/s) with brake	23.0	38.3	58.0
Rotor Inertia (×10 ⁻⁴ kg.m ²)	12.44	18.00	22.60
Rotor Inertia (×10 ⁻⁴ kg.m ²) with brake	12.62	18.14	22.80
Mechanical Time Constant (ms)	2.5	1.97	1.69
Mechanical Time Constant (ms) with brake	2.54	1.99	1.71
Torque Constant -KT (N-m/A)	1.61	2.17	2.00
Voltage Constant -KE (mV/(rpm))	59.5	77.6	70.7
Armature Resistance (Ohm)	1.84	1.76	1.01
Armature Inductance (mH)	10.0	11.0	6.80
Electrical Time Constant (ms)	5.43	6.25	6.73
Weight – without brake (kg)	6.0	7.0	8.0
Weight – with brake (kg)	7.5	8.5	9.5
Max. Radial Loading (N) ⁵	490	686	980
Max. Axial Loading (N) ⁵	98	343	392
Brake Working Voltage	24 V _{DC} ± 10%		
Brake Power Consumption (at 20°C)[W]	24	24	24
Brake Holding Torque [Nt-m (min)] ^{*3}	16	16	16
Brake Release Time [ms (Max)]	60	60	60
Brake Pull-In Time [ms (Max)]	120	120	120
Derating (%) (with oil seal)	5	5	5
Torque Feature (T-N Curve)	<p>— ASD-B3□-1543-□ - - - ASD-B3□-1503-□</p> <p>Torque (N-m): 16.17(300%), 13.6(252%), 11.55(214%), 8.57(159%), 5.39(100%), 2.02(38%)</p> <p>Speed (rpm): 1500, 2700, 3000, 4000</p>	<p>— ASD-B3□-2043-□ - - - ASD-B3□-1543-□</p> <p>Torque (N-m): 25.02(300%), 22.14(266%), 16.47(198%), 13.2(158%), 8.34(100%), 3.13(38%)</p> <p>Speed (rpm): 1500, 2200, 2100, 4000</p>	<p>Torque (N-m): 34.5(300%), 24.67(214%), 13.9(121%), 11.5(100%), 4.31(38%)</p> <p>Speed (rpm): 1500, 2300, 4000</p>
Insulation Class	Class F (UL), Class F (CE)		
Insulation Resistance	> 100 MΩ · DC 500 V		
Insulation Strength	2.3 k V _{AC} · 1 sec		
Vibration Level (μm)	V15		
Operating Temperature	-20°C ~ 60°C* ⁴		
Storage Temperature	-20°C ~ 80°C		
Storage & Operation Humidity	20 ~ 90% RH (non-condensing)		
Vibration Capacity	2.5 G		
IP Rating	IP67 (when using waterproof connections and when an oil seal is fitted to the rotating shaft (for an oil seal model))		
Certifications			

Notes:

- In the servo motor model name, 2 represents the encoder type
- If the motor frame temperature exceeds 90° C, please enhance heat dissipation (e.g., install a heat sink). The rated torque is the continuous permissible torque between 0 to 40°C operating temperature which is suitable for the servo motor mounted with the following heat sink dimensions.
F100: 300 mm x 300 mm x 12 mm
F130: 400 mm x 400 mm x 20 mm
- The built-in servo motor brake is only for keeping the object in a stopped state.
- If the operating temperature is over 40°C, refer to the power derating curves of B3 motors on page 37 on page 37.

- Please follow the max. tolerant loading of the motor shaft end listed below during operation

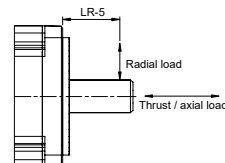

Ordering Information

ECM-B3H Series Servo Motor Specifications (400 V)

	ECM-B3M-J 1010	ECM-B3M-J 1015	ECM-B3M-J 1020
Rated Power (kW)	1	1.5	2
Rated Torque (N-m) ^{*2}	3.18	4.77	6.37
Maximum Torque (N-m)	9.54	14.31	19.11
Rated Speed (rpm)	3,000		
Maximum Speed (rpm)	6,000		
Rated Current (Arms)	3.03	3.73	5.00
Max. Instantaneous Current (Arms)	9.21	11.4	15.3
Rated Power Rate (kW/s)	36.4	61.7	86.7
Rated Power Rate (kW/s) with brake	33	57.3	82.0
Rotor Inertia (×10 ⁻⁴ kg.m ²)	2.78	3.69	4.68
Rotor Inertia (×10 ⁻⁴ kg.m ²) with brake	3.06	3.97	82.0
Mechanical Time Constant (ms)	0.737	0.546	0.528
Mechanical Time Constant (ms) with brake	0.811	0.587	0.559
Torque Constant -KT (N-m/A)	1.05	1.28	1.27
Voltage Constant -KE (mV/(rpm))	39.5	47.8	47.2
Armature Resistance (Ohm)	1.05	0.864	0.646
Armature Inductance (mH)	7.5	6.63	4.89
Electrical Time Constant (ms)	7.50	7.67	7.57
Weight – without brake (kg)	3.56	4.37	5.09
Weight – with brake (kg)	4.88	5.68	6.505
Max. Radial Loading (N) ^{*5}	490	490	490
Max. Axial Loading (N) ^{*5}	196	196	196
Brake Working Voltage	24 V _{DC} ± 10%		
Brake Power Consumption (at 20°C)[W]	17.6	17.6	17.6
Brake Holding Torque [Nt-m (min)] ^{*3}	9.5	9.5	9.5
Brake Release Time [ms (Max)]	50	50	50
Brake Pull-In Time [ms (Max)]	110	110	110
Derating (%) (with oil seal)	5	5	5
Torque Feature (T-N Curve)			
Insulation Class	Class A (UL) , Class B (CE)		
Insulation Resistance	> 100 MΩ , DC 500 V		
Insulation Strength	2.3k V _{AC} , 1 sec		
Vibration Level (μm)	V15		
Operating Temperature	-20°C ~ 60°C*4		
Storage Temperature	-20°C ~ 80°C		
Storage & Operation Humidity	20 ~ 90% RH (non-condensing)		
Vibration Capacity	2.5 G		
IP Rating	IP67		
Certifications			

Notes:

- In the servo motor model name, 2 represents the encoder type
- If the motor frame temperature exceeds 90°C, please enhance heat dissipation (e.g., install a heat sink). The rated torque is the continuous permissible torque between 0 to 40°C operating temperature which is suitable for the servo motor mounted with the following heat sink dimensions.
F100: 300mm x 300mm x 12mm
F130: 400mm x 400mm x 20mm
- The built-in servo motor brake is only for keeping the object in a stopped state.
- If the operating temperature is over 40°C, refer to the power derating curves of B3 motors on page 37 on page 37.
- Please follow the max. tolerant loading of the motor shaft end listed below during operation

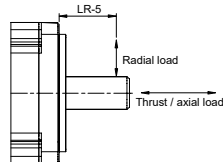

Ordering Information

ECM-B3M Series Servo Motor Specifications (400 V)

	ECM-B3M-K □ 1310	ECM-B3M-K □ 1315	ECM-B3M-K □ 1320
Rated Power (kW)	1	1.5	2
Rated Torque (N-m) ^{*2}	4.77	7.16	9.55
Maximum Torque (N-m)	14.3	21.48	28.65
Rated Speed (rpm)	2,000		
Maximum Speed (rpm)	3,000		
Rated Current (Arms)	3.00	4.09	5.30
Max. Instantaneous Current (Arms)	9.95	13.37	17.1
Rated Power Rate (kW/s)	29.21	45.69	62.25
Rated Power Rate (kW/s) with brake	28.66	45.09	61.62
Rotor Inertia (×10 ⁻⁴ kg.m ²)	7.79	11.22	14.65
Rotor Inertia (×10 ⁻⁴ kg.m ²) with brake	7.94	11.37	14.80
Mechanical Time Constant (ms)	1.47	1.10	1.03
Mechanical Time Constant (ms) with brake	1.50	1.12	1.04
Torque Constant -KT (N-m/A)	1.59	1.75	1.80
Voltage Constant -KE (mV/(rpm))	58.60	63.38	65.40
Armature Resistance (Ohm)	1.68	1.04	0.792
Armature Inductance (mH)	16.0	11.2	8.72
Electrical Time Constant (ms)	9.52	10.8	11.0
Weight – without brake (kg)	4.9	6.0	7.0
Weight – with brake (kg)	6.3	7.4	8.5
Max. Radial Loading (N) ^{*5}	490	686	980
Max. Axial Loading (N) ^{*5}	98	343	392
Brake Working Voltage	24 V _{DC} ± 10%		
Brake Power Consumption (at 20°C)[W]	21.5	21.5	21.5
Brake Holding Torque [Nt-m (min)] ^{*3}	10	10	10
Brake Release Time [ms (Max)]	50	50	50
Brake Pull-In Time [ms (Max)]	110	110	110
Derating (%) (with oil seal)	5	5	5
Torque Feature (T-N Curve)			
Insulation Class	Class A (UL) , Class B (CE)		
Insulation Resistance	> 100 MΩ , DC 500 V		
Insulation Strength	2.3 k V _{AC} , 1 sec		
Vibration Level (μm)	V15		
Operating Temperature	-20°C ~ 60°C*4		
Storage Temperature	-20°C ~ 80°C		
Storage & Operation Humidity	20 ~ 90% RH (non-condensing)		
Vibration Capacity	2.5 G		
IP Rating	IP67		
Certifications			

Notes:

- In the servo motor model name, 2 represents the encoder type
- If the motor frame temperature exceeds 90°C, please enhance heat dissipation (e.g., install a heat sink).
The rated torque is the continuous permissible torque between 0 to 40°C operating temperature which is suitable for the servo motor mounted with the following heat sink dimensions.
F100: 300 mm x 300 mm x 12 mm
F130: 400 mm x 400 mm x 20 mm
- The built-in servo motor brake is only for keeping the object in a stopped state.
- If the operating temperature is over 40°C, refer to the power derating curves of B3 motors on page 37 on page 37.

- Please follow the max. tolerant loading of the motor shaft end listed below during operation

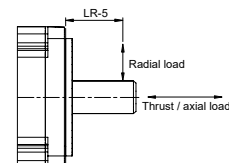

Ordering Information

ECM-B3M Series Servo Motor Specifications (400 V)

	ECM-B3M-K □ 1820	ECM-B3M-L □ 1830	ECM-B3M-L □ 1845
Rated Power (kW)	2	3	4.5
Rated Torque (N-m) ^{*2}	9.55	19.1	28.65
Maximum Torque (N-m)	28.65	57.29	71.6
Rated Speed (rpm)	2,000	1,500	1,500
Maximum Speed (rpm)	3,000	3,000	4,000
Rated Current (Arms)	5.7	9.1	13.3
Max. Instantaneous Current (Arms)	18.1	29.45	35.35
Rated Power Rate (kW/s)	31.33	68.02	121
Rated Power Rate (kW/s) with brake	30.02	66.45	119
Rotor Inertia (×10 ⁻⁴ kg.m ²)	29.11	53.63	67.73
Rotor Inertia (×10 ⁻⁴ kg.m ²) with brake	30.38	54.9	69.15
Mechanical Time Constant (ms)	1.83	1.21	1.07
Mechanical Time Constant (ms) with brake	1.91	1.24	1.09
Torque Constant -KT (N-m/A)	1.68	2.10	2.15
Voltage Constant -KE (mV/(rpm))	63.2	75.8	78.8
Armature Resistance (Ohm)	0.636	0.344	0.255
Armature Inductance (mH)	9.36	6.08	4.68
Electrical Time Constant (ms)	14.72	17.67	18.4
Weight – without brake (kg)	10	13.9	16.5
Weight – with brake (kg)	13.7	17.6	20.2
Max. Radial Loading (N) ^{*5}	1,470	1,470	1,470
Max. Axial Loading (N) ^{*5}	490	490	490
Brake Working Voltage	24 V _{DC} ± 10%		
Brake Power Consumption (at 20°C)[W]	31	31	31
Brake Holding Torque [Nt-m (min)] ^{*3}	25	25	55
Brake Release Time [ms (Max)]	30	30	50
Brake Pull-In Time [ms (Max)]	120	120	150
Derating (%) (with oil seal)	5	5	0
Torque Feature (T-N Curve)			
Insulation Class	Class A (UL) , Class B (CE)		Class F (UL) , Class F (CE)
Insulation Resistance	> 100 MΩ , DC 500 V		
Insulation Strength	2.3 k V _{AC} , 1 sec		
Vibration Level (μm)	V15		
Operating Temperature	-20°C ~ 60°C*4		
Storage Temperature	-20°C ~ 80°C		
Storage & Operation Humidity	20 ~ 90% RH (non-condensing)		
Vibration Capacity	2.5 G		
IP Rating	IP67		
Certifications			

Notes:

- In the servo motor model name, 2 represents the encoder type
- If the motor frame temperature exceeds 90° C, please enhance heat dissipation (e.g., install a heat sink). The rated torque is the continuous permissible torque between 0 to 40°C operating temperature which is suitable for the servo motor mounted with the following heat sink dimensions.
F100: 300 mm x 300 mm x 12 mm
F130: 400 mm x 400 mm x 20 mm
- The built-in servo motor brake is only for keeping the object in a stopped state.
- If the operating temperature is over 40°C, refer to the power derating curves of B3 motors on page 37 on page 37.

- Please follow the max. tolerant loading of the motor shaft end listed below during operation

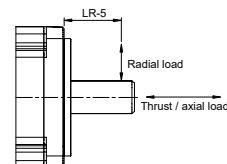

Ordering Information

ECM-B3M Series Servo Motor Specifications (400 V)

	ECM-B3M-L □ 1855	ECM-B3M-L □ 1875
Rated Power (kW)	5.5	7.5
Rated Torque (N-m) ^{*2}	35.01	47.75
Maximum Torque (N-m)	105	119
Rated Speed (rpm)	1,500	
Maximum Speed (rpm)	4,000	
Rated Current (Arms)	15.3	22.1
Max. Instantaneous Current (Arms)	49.29	56.68
Rated Power Rate (kW/s)	124	169
Rated Power Rate (kW/s) with brake	122	167
Rotor Inertia (×10 ⁻⁴ kg.m ²)	98.88	134.95
Rotor Inertia (×10 ⁻⁴ kg.m ²) with brake	100.1	136.24
Mechanical Time Constant (ms)	1.01	1.01
Mechanical Time Constant (ms) with brake	1.02	1.02
Torque Constant -KT (N-m/A)	2.29	2.16
Voltage Constant -KE (mV/(rpm))	81.8	77.4
Armature Resistance (Ohm)	0.182	0.120
Armature Inductance (mH)	3.48	2.27
Electrical Time Constant (ms)	19.1	18.9
Weight - without brake (kg)	21.2	27.2
Weight - with brake (kg)	24.9	30.9
Max. Radial Loading (N) ^{*5}	1764	1764
Max. Axial Loading (N) ^{*5}	588	588
Brake Working Voltage	24 V _{DC} ± 10%	
Brake Power Consumption (at 20°C)[W]	31	31
Brake Holding Torque [Nt-m (min)] ^{*3}	55	55
Brake Release Time [ms (Max)]	50	50
Brake Pull-In Time [ms (Max)]	150	150
Derating (%) (with oil seal)	0	0
Torque Feature (T-N Curve)		
Insulation Class	Class F (UL) › Class F (CE)	
Insulation Resistance	> 100 MΩ › DC 500 V	
Insulation Strength	2.3k V _{AC} › 1sec	
Vibration Level (μm)	V15	
Operating Temperature	-20°C ~ 60°C*4	
Storage Temperature	-20°C ~ 80°C	
Storage & Operation Humidity	20 ~ 90% RH (non-condensing)	
Vibration Capacity	2.5G	
IP Rating	IP67	
Certifications		

Notes:

- In the servo motor model name, 2 represents the encoder type
- If the motor frame temperature exceeds 90°C, please enhance heat dissipation (e.g., install a heat sink). The rated torque is the continuous permissible torque between 0 to 40°C operating temperature which is suitable for the servo motor mounted with the following heat sink dimensions.
F100: 300 mm x 300 mm x 12 mm
F130: 400 mm x 400 mm x 20 mm
- The built-in servo motor brake is only for keeping the object in a stopped state.
- If the operating temperature is over 40°C, refer to the power derating curves of B3 motors on page 37 on page 37.

- Please follow the max. tolerating loading of the motor shaft end listed below during operation

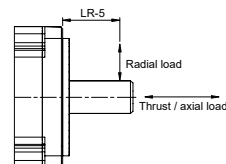

Ordering Information

ECM-B3M Series Servo Motor Specifications (400 V)

	ECM-B3M- L □ 221B	ECM-B3M- L □ 221F
Rated Power (kW)	11	15
Rated Torque (N-m) ^{*2}	70.03	95.49
Maximum Torque (N-m)	175	238.5
Rated Speed (rpm)	1,500	
Maximum Speed (rpm)	4,000	
Rated Current (Arms)	21.2	29.2
Max. Instantaneous Current (Arms)	56.5	77
Rated Power Rate (kW/s)	162	228
Rated Power Rate (kW/s) with brake	162	227
Rotor Inertia (×10 ⁻⁴ kg.m ²)	302.2	400
Rotor Inertia (×10 ⁻⁴ kg.m ²) with brake	303.1	400.9
Mechanical Time Constant (ms)	1.03	0.94
Mechanical Time Constant (ms) with brake	1.04	0.94
Torque Constant -KT (N-m/A)	3.3	3.27
Voltage Constant -KE (mV/(rpm))	118	118
Armature Resistance (Ohm)	0.127	0.0862
Armature Inductance (mH)	3.69	2.43
Electrical Time Constant (ms)	29.1	28.2
Weight – without brake (kg)	50.9	62.1
Weight – with brake (kg)	58.2	69.4
Max. Radial Loading (N) ^{*5}	3300	3300
Max. Axial Loading (N) ^{*5}	1100	1100
Brake Working Voltage	24 V _{DC} ± 10%	
Brake Power Consumption (at 20°C)[W]	32	32
Brake Holding Torque [Nt-m (min)] ^{*3}	115	115
Brake Release Time [ms (Max)]	100	100
Brake Pull-In Time [ms (Max)]	300	300
Derating (%) (with oil seal)	0	0
Torque Feature (T-N Curve)		
Insulation Class	Class F (UL) , Class F (CE)	
Insulation Resistance	> 100MΩ , DC 500 V	
Insulation Strength	2.3k V _{AC} , 1 sec	
Vibration Level (μm)	V15	
Operating Temperature	-20°C ~ 60°C*4	
Storage Temperature	-20°C ~ 80°C	
Storage & Operation Humidity	20 ~ 90% RH (non-condensing)	
Vibration Capacity	2.5 G	
IP Rating	IP67	
Certifications		

Notes:

- In the servo motor model name, 2 represents the encoder type
- If the motor frame temperature exceeds 90°C, please enhance heat dissipation (e.g., install a heat sink).
The rated torque is the continuous permissible torque between 0 to 40°C operating temperature which is suitable for the servo motor mounted with the following heat sink dimensions.
F100: 300 mm x 300 mm x 12 mm
F130: 400 mm x 400 mm x 20 mm
- The built-in servo motor brake is only for keeping the object in a stopped state.
- If the operating temperature is over 40°C, refer to the power derating curves of B3 motors on page 37 on page 37.

- Please follow the max. tolerant loading of the motor shaft end listed below during operation

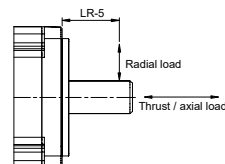

Ordering Information

ECM-B3 Series Servo Motor Specifications Power Derating Curves

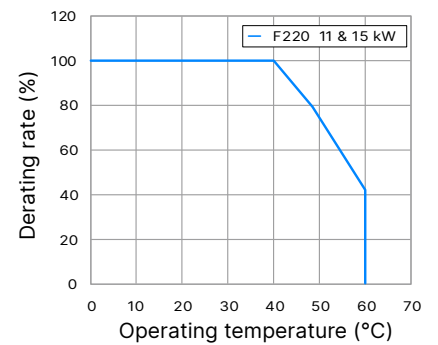
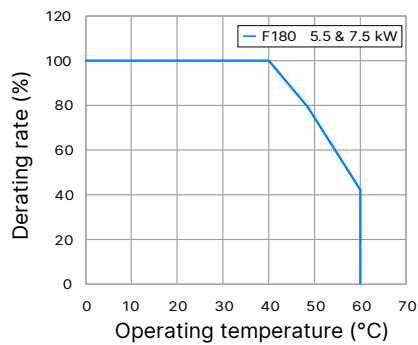
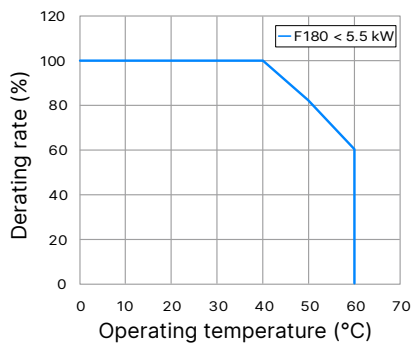
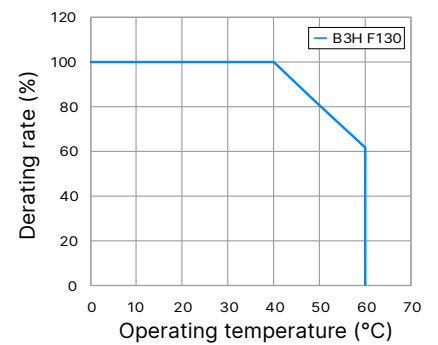
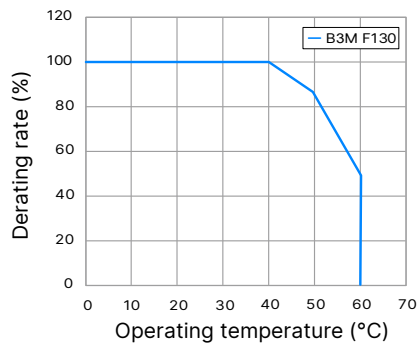
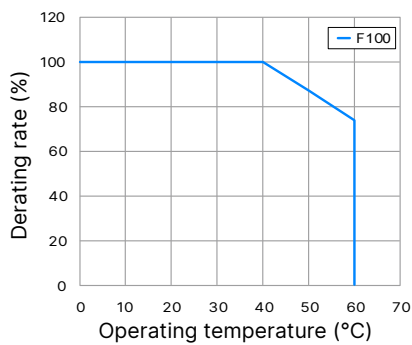
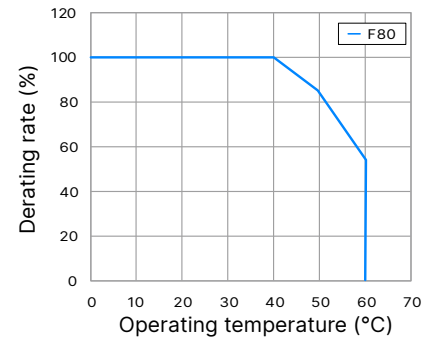
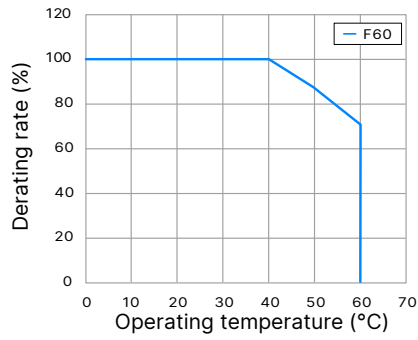
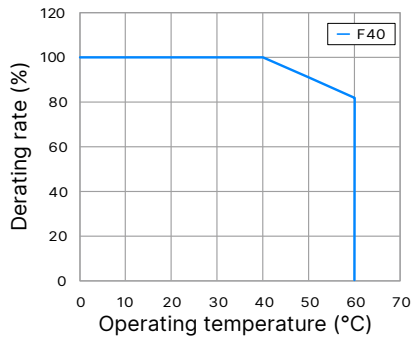

Ordering Information

ECM-B3 Built-in Series Servo Motor Specifications 400 V, Frame Size 60/80 mm

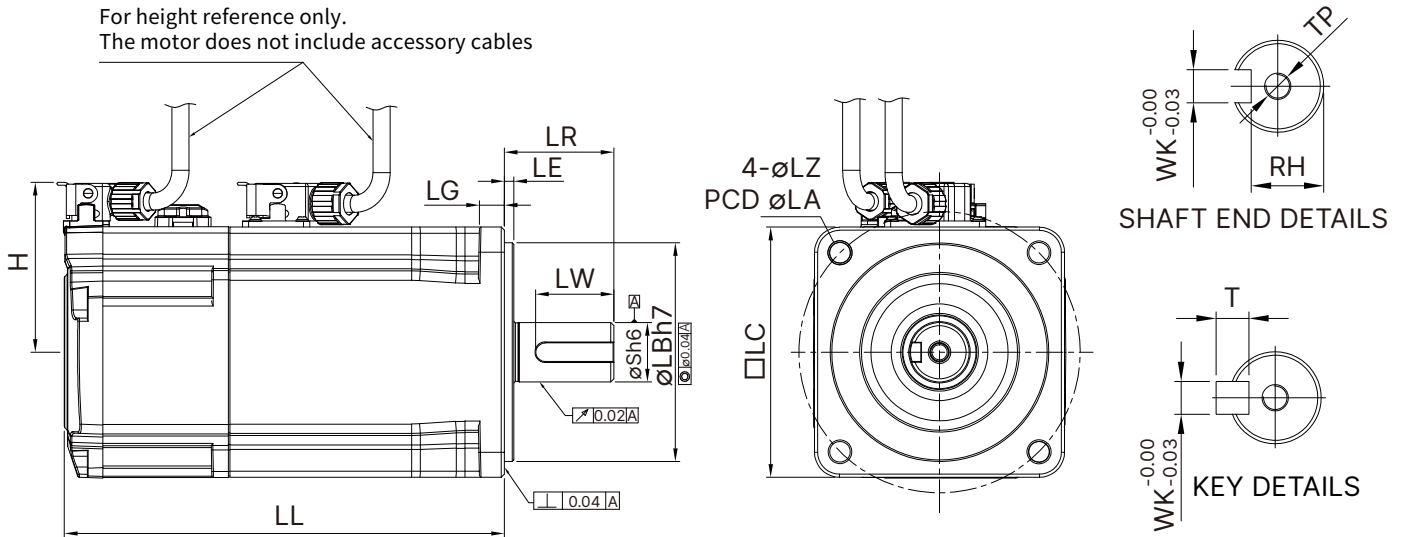

Model	B3M-J* ② 0604	B3M-J* ② 0807
LC	60	80
LZ	5.5	6.6
LA	70	90
S	14 ^(+0/-0.011)	19 ^(+0/-0.013)
LB	50 ^(+0/-0.025)	70 ^(+0/-0.030)
LL (w/o brake)	91	105.2
LL (with brake)	122.9	140.8
H	44	54
LR	30	35
LE	3	3
LG	7.5	8
LW	20	25
RH	11	15.5
WK	5	6
W	5	6
T	5	6
TP	M4 Depth 15	M6 Depth 20

Note: 1. Servo motor model name: ② = encoder type
2. The length of battery-less encoder frame LL increases as shown below

F60/F80
+6.5mm

Ordering Information

ECM-B3 Series Servo Motor Specifications 400 V, Frame Size 100 mm

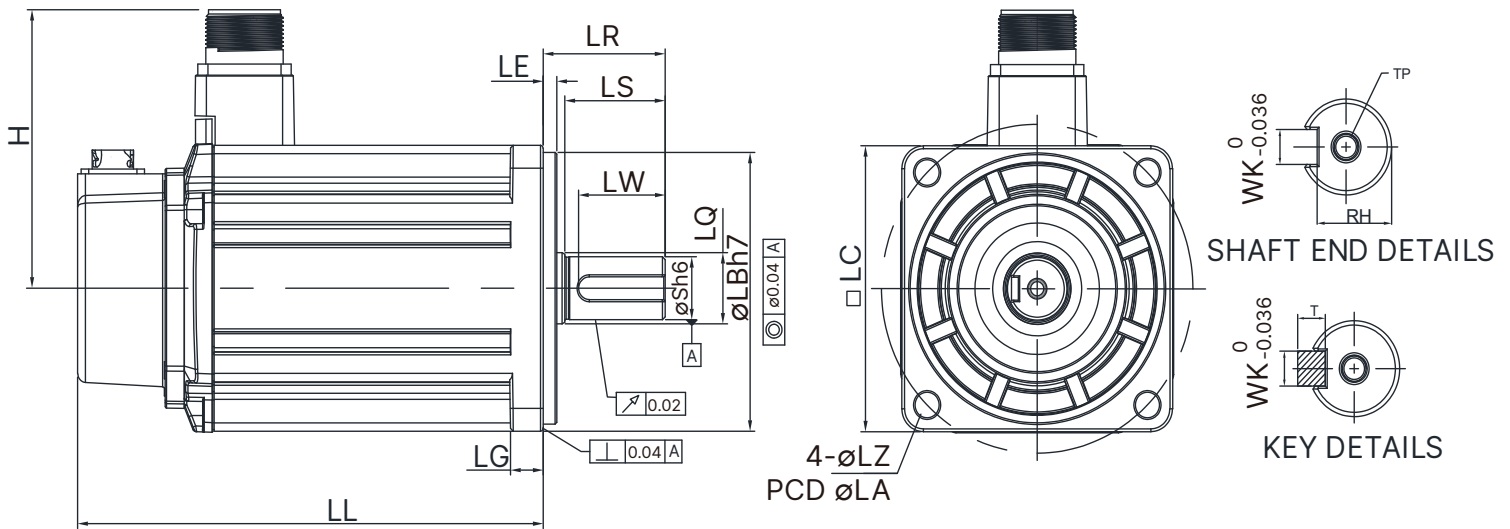

Model	B3M-J ② 1010	B3M-J ② 1015	B3M-J ② 1020
LC	100	100	100
LZ	9	9	9
LA	115	115	115
S	22 ^(+0/-0.013)	22 ^(+0/-0.013)	22 ^(+0/-0.013)
LB	95 ^(+0/-0.03)	95 ^(+0/-0.03)	95 ^(+0/-0.03)
LL (w/o brake)	141.8	156.8	171.8
LL (with brake)	179.9	194.9	209.9
H	97.4	97.4	97.4
LS	37	37	37
LR	45	45	45
LQ	25	25	25
LE	5	5	5
LG	12	12	12
LW	32	32	32
RH	18	18	18
WK	8	8	8
W	8	8	8
T	7	7	7
TP	M6 Depth 12	M6 Depth 12	M6 Depth 12

Note: 1. Servo motor model name: ② = encoder type
2. The length of battery-less encoder frame LL increases as shown below

F100/F130/F180
+6.5mm

Ordering Information

ECM-B3 Series Servo Motor Specifications 400V, Frame Size 130 m

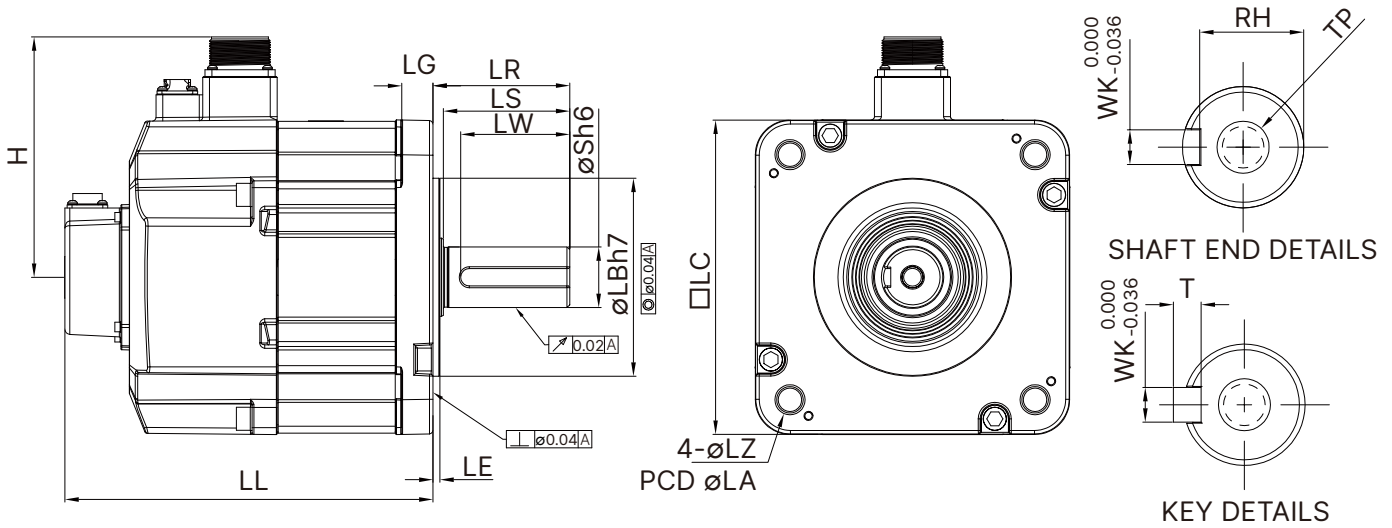

Model	B3M-K ② 1310	B3M-K ② 1315	B3M-K ② 1320	B3H-L ② 1308	B3H-L ② 1313	B3H-L ② 1318
LC	130	130	130	130	130	130
LZ	9	9	9	9	9	9
LA	145	145	145	145	145	145
S	22($^{+0}_{-0.013}$)	22($^{+0}_{-0.013}$)	22($^{+0}_{-0.013}$)	22($^{+0}_{-0.013}$)	22($^{+0}_{-0.013}$)	22($^{+0}_{-0.013}$)
LB	110($^{+0}_{-0.035}$)	110($^{+0}_{-0.035}$)	110($^{+0}_{-0.035}$)	110($^{+0}_{-0.035}$)	110($^{+0}_{-0.035}$)	110($^{+0}_{-0.035}$)
LL (w/o brake)	127.9	139.9	151.9	127.9	139.9	151.9
LL (with brake)	168.5	180.5	192.5	168.5	180.5	192.5
H	115	115	115	115	115	115
LS	47	47	47	47	47	47
LR	55	55	55	55	55	55
LQ	28	28	28	28	28	28
LE	6	6	6	6	6	6
LG	12.5	12.5	12.5	12.5	12.5	12.5
LW	36	36	36	36	36	36
RH	18	18	18	18	18	18
WK	8	8	8	8	8	8
W	8	8	8	8	8	8
T	7	7	7	7	7	7
TP	M6 Depth 12	M6 Depth 12	M6 Depth 12	M6 Depth 12	M6 Depth 12	M6 Depth 12

Note: 1. Servo motor model name: ② = encoder type
2. The length of battery-less encoder frame LL increases as shown below

F130
+6.5mm

Ordering Information

ECM-B3 Series Servo Motor Specifications 400 V, Frame Size 180 mm

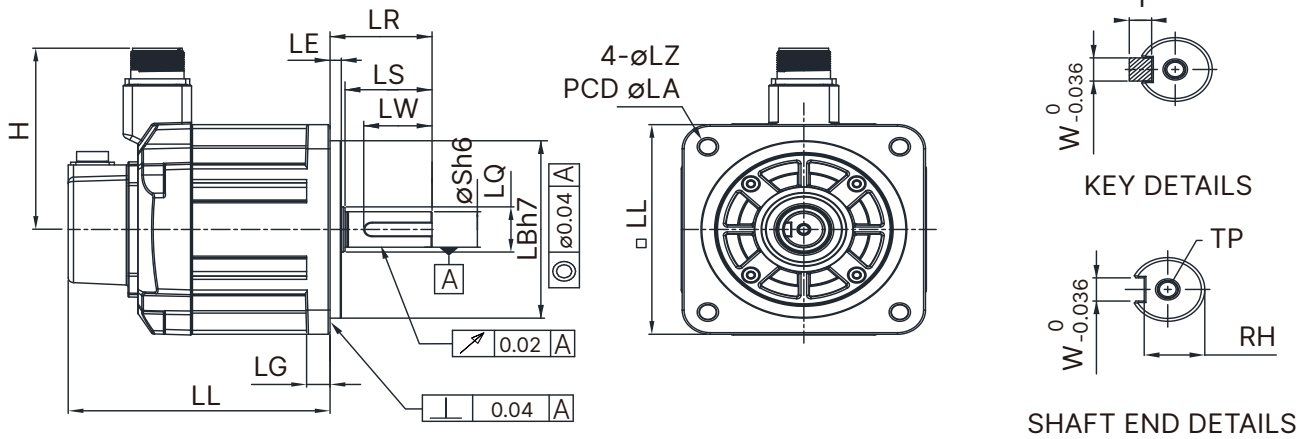

Model	B3M-K ② 1820	B3M-L ② 1830	B3M-L ② 1845
LC	180	180	180
LZ	13.5	13.5	13.5
LA	200	200	200
S	35 ^(+0/-0.016)	35 ^(+0/-0.016)	35 ^(+0/-0.016)
LB	114.3 ^(+0/-0.035)	114.3 ^(+0/-0.035)	114.3 ^(+0/-0.035)
LL (w/o brake)	137.5	160.5	174
LL (with brake)	189.5	212.5	226
H	139	139	139
LS	73	73	73
LR	79	79	79
LQ	45	45	45
LE	4	4	4
LG	18	18	18
LW	63	63	63
RH	30	30	30
WK	10	10	10
W	10	10	10
T	8	8	8
TP	M12 Depth 25	M12 Depth 25	M12 Depth 25

Note: 1. Servo motor model name: ② = encoder type
2. The length of battery-less encoder frame LL increases as shown below

F180
+6.5mm

Ordering Information

ECM-B3 Series Servo Motor Specifications 400V, Frame Size 180 mm

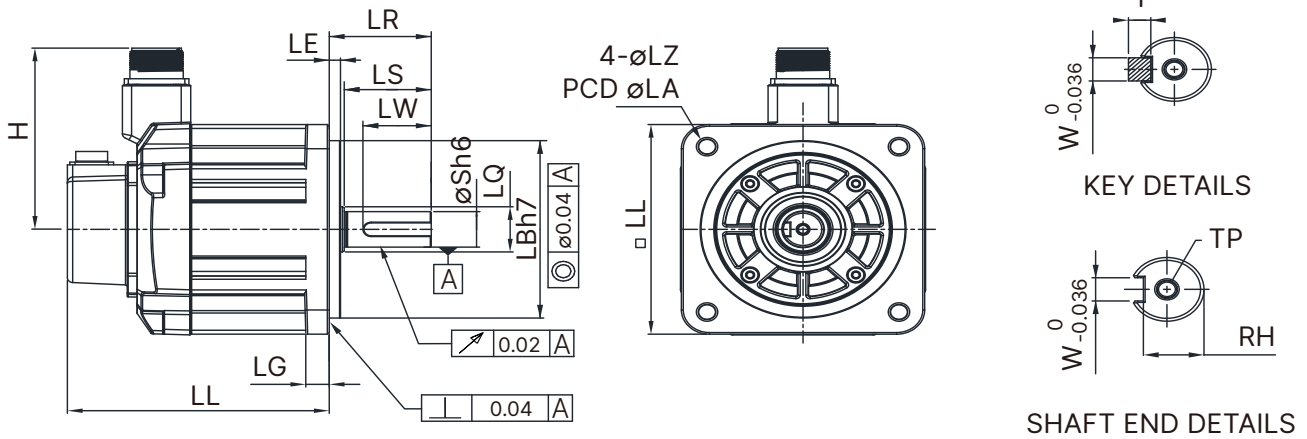

Model	B3M-L ② 1855	B3M-L ② 1875
LC	180	180
LZ	13.5	13.5
LA	200	200
S	42($^{+0}_{-0.016}$)	42($^{+0}_{-0.016}$)
LB	114.3($^{+0}_{-0.035}$)	114.3($^{+0}_{-0.035}$)
LL (w/o brake)	218	260.1
LL (with brake)	265	307.1
H	144.5	144.5
LS	108.5	108.5
LR	113	113
LQ	45	45
LE	4	4
LG	18	18
LW	90	90
RH	37	37
WK	12	12
W	12	12
T	8	8
TP	M16 Depth 32	M16 Depth 32

Note: 1. Servo motor model name: ② = encoder type
2. The length of battery-less encoder frame LL increases as shown below

F180
+6.5mm

Ordering Information

ECM-B3 Series Servo Motor Specifications 400 V, Frame Size 220 mm

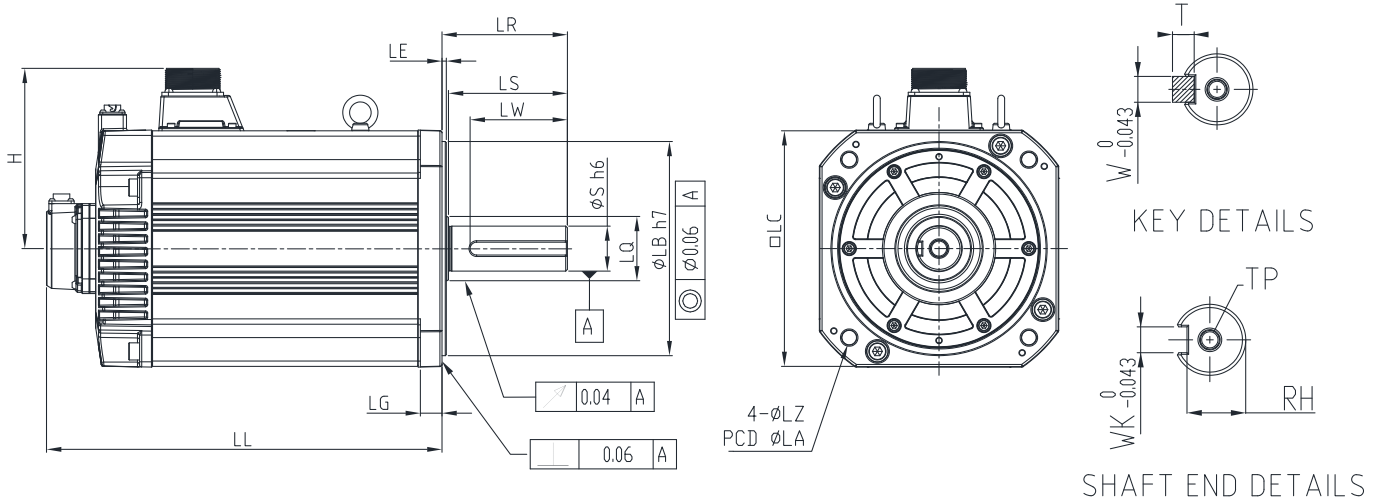

Model	B3M-L ② 221B	B3M-L ② 221F
LC	220	220
LZ	13.5	13.5
LA	235	235
S	42($\begin{smallmatrix} +0 \\ -0.016 \end{smallmatrix}$)	55($\begin{smallmatrix} +0 \\ -0.016 \end{smallmatrix}$)
LB	200($\begin{smallmatrix} +0 \\ -0.035 \end{smallmatrix}$)	200($\begin{smallmatrix} +0 \\ -0.035 \end{smallmatrix}$)
LL (w/o brake)	331.5	365.6
LL (with brake)	378.5	412.6
H	168.3	168.3
LS	110	110
LR	116	116
LQ	60	60
LE	4	4
LG	20	20
LW	90	90
RH	37	49
WK	12	16
W	12	16
T	8	10
TP	M16 Depth32	M20 Depth 40

Note: 1. Servo motor model name: ② = encoder type

Ordering Information

EtherCAT Communication Mode Standard Wiring

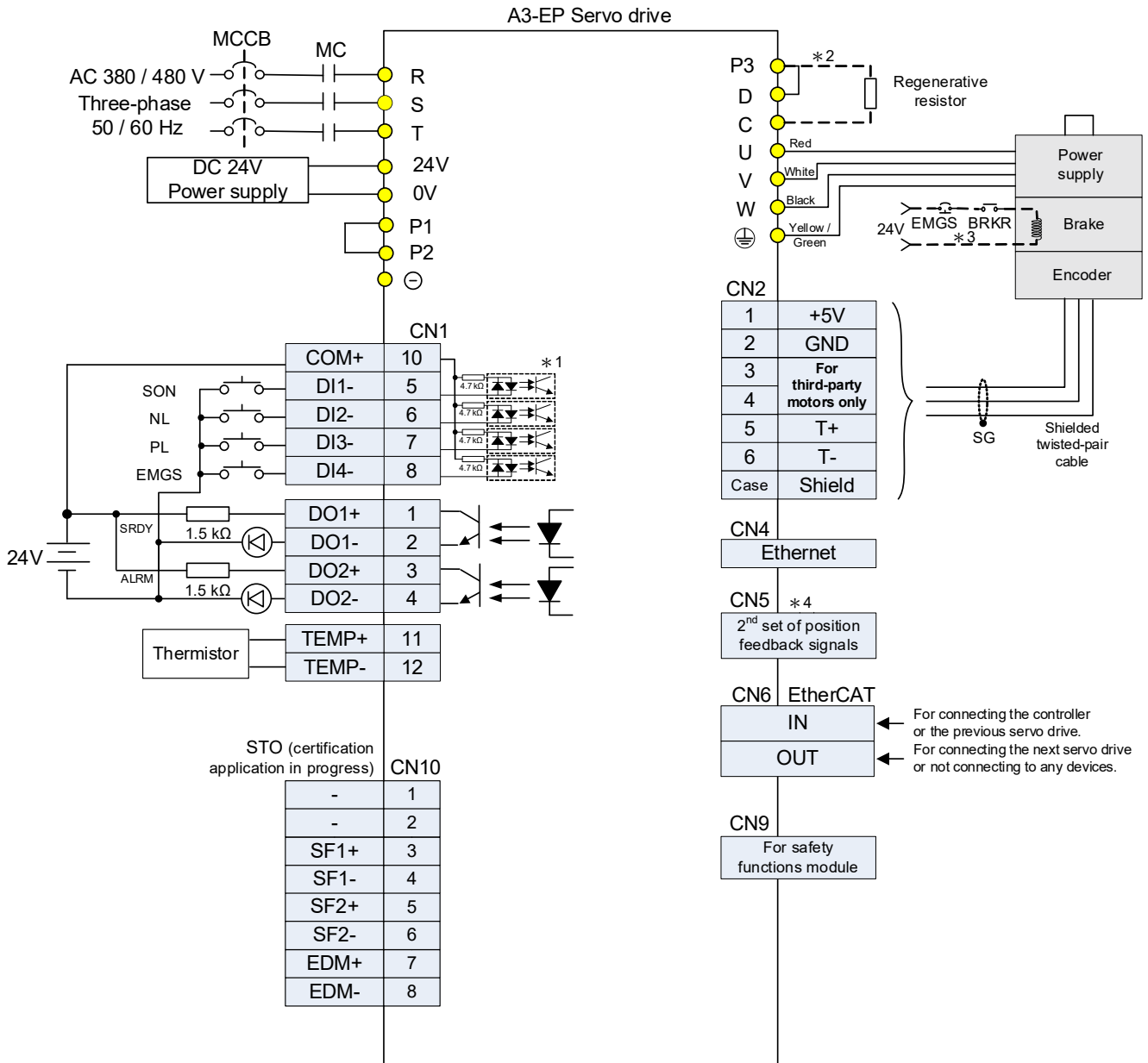

Notes:

- *1: Refer to Section 3.3 in the ASDA-A3-EP user manual for wiring
- *2: Models of 2 kW and above have no built-in regenerative resistor
- *3: The brake coil has no polarity
- *4: Please refer to Section 3.6 for the pin assignment of the CN5 connector (second set of position feedback signals).

Ordering Information

Accessories

Built-in Motor with Frame Size of 80 mm or Below

Power Connectors

ACS3-AFPWSS00

With or w/o brake
Cable exit direction towards motor shaft

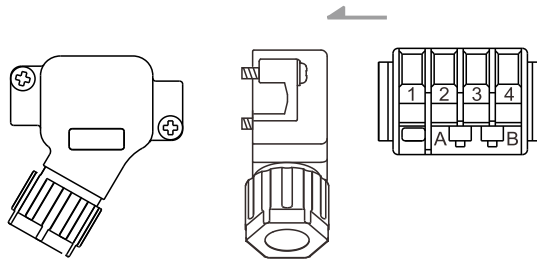

ACS3-ABPWSS00

With or w/o brake
Cable exit direction towards encoder

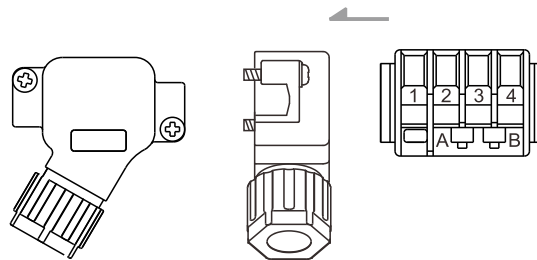

Encoder Connectors

ACS3-AFEASA00

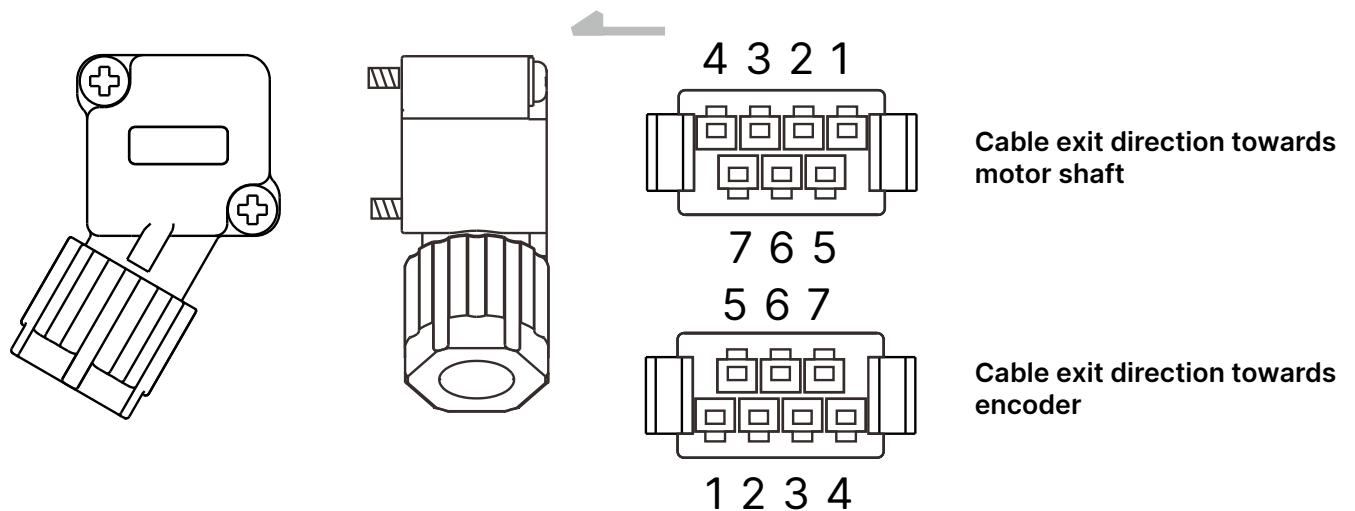

Ordering Information

Accessories

Power Connectors (For F100 and above)

ACS3-CAP WA000
(for F100 ~ F130)
Mil-Spec: MIL 3106A18-10S

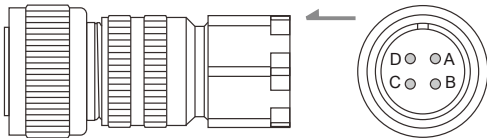

ACS3-CAP WE000
(F180 5.5kW and above)
Mil-Spec: MIL 3106A32-17S

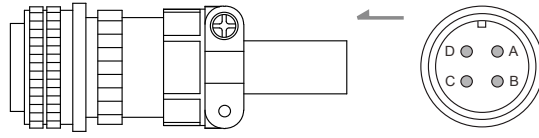

ACS3-CRP WA000
(for F100 ~ F130)
Mil-Spec: MIL 3108A18-10S

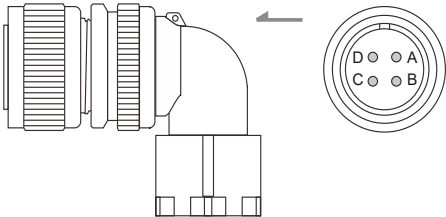

ACS3-CRP WE000
(for F180 5.5kW and above)
Mil-Spec: MIL 3108A32-17S

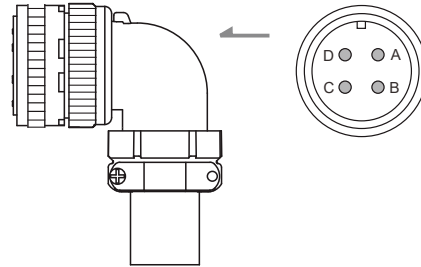

ACS3-CAP WC000
(for F180 2/3/4.5kW)
Mil-Spec: MIL 3106A22-22S

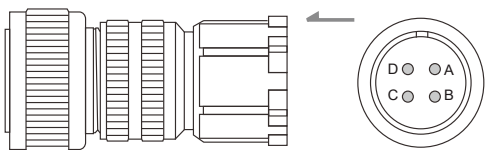

ACS3-CABRA000
(for F100 ~ F220 Brake Model Applicable)
Mil-Spec: CMV1-SP2S

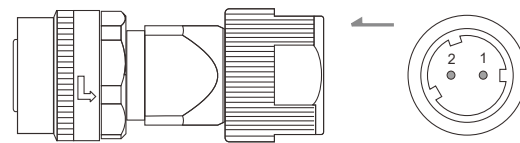

ACS3-CRP WC000
(for F180 2/3/4.5kW)
Mil-Spec: MIL 3108A22-22S

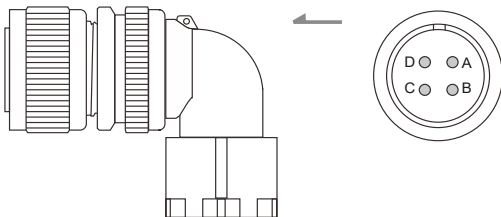

ACS3-CRBRA000
(for F100 ~ F220 Brake Model Applicable)
Mil-Spec: CMV1-AP2S

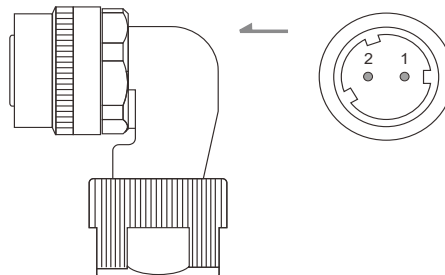

Ordering Information

Accessories

Power Cables w/o brake

Cable exit direction towards motor shaft

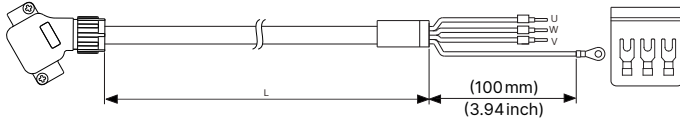

Cable	Model Name	UVW	L	
		AWG (mm ²)	mm	inch
Standard	ACS3-AFPWSA03	20 (0.5)	3,000 ± 50	118 ± 2
	ACS3-AFPWSA05	20 (0.5)	5,000 ± 50	197 ± 2
	ACS3-AFPWSA10	20 (0.5)	10,000 ± 100	394 ± 4
	ACS3-AFPWSA20	20 (0.5)	20,000 ± 100	787 ± 4
Torsion-Resistant	ACS3-AFPRSA03	20 (0.5)	3,000 ± 50	118 ± 2
	ACS3-AFPRSA05	20 (0.5)	5,000 ± 50	197 ± 2
	ACS3-AFPRSA10	20 (0.5)	10,000 ± 100	394 ± 4
	ACS3-AFPRSA20	20 (0.5)	20,000 ± 100	787 ± 4

Cable exit direction towards encoder

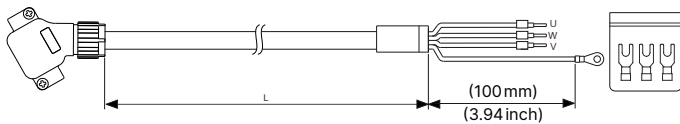

Cable	Model Name	UVW	L	
		AWG (mm ²)	mm	inch
Standard	ACS3-ABPWSA03	20 (0.5)	3,000 ± 50	118 ± 2
	ACS3-ABPWSA05	20 (0.5)	5,000 ± 50	197 ± 2
	ACS3-ABPWSA10	20 (0.5)	10,000 ± 100	394 ± 4
	ACS3-ABPWSA20	20 (0.5)	20,000 ± 100	787 ± 4
Torsion-Resistant	ACS3-ABPRSA03	20 (0.5)	3,000 ± 50	118 ± 2
	ACS3-ABPRSA05	20 (0.5)	5,000 ± 50	197 ± 2
	ACS3-ABPRSA10	20 (0.5)	10,000 ± 100	394 ± 4
	ACS3-ABPRSA20	20 (0.5)	20,000 ± 100	787 ± 4

Power Cables with brake

Cable exit direction towards motor shaft

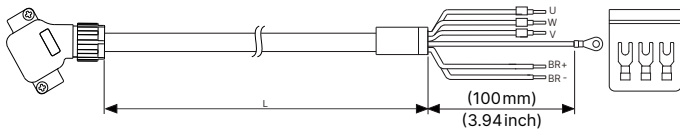

Cable	Model Name	UVW	L	
		AWG (mm ²)	mm	inch
Standard	ACS3-AFPWSB03	20 (0.5) + 24 (0.2)	3,000 ± 50	118 ± 2
	ACS3-AFPWSB05	20 (0.5) + 24 (0.2)	5,000 ± 50	197 ± 2
	ACS3-AFPWSB10	20 (0.5) + 24 (0.2)	10,000 ± 100	394 ± 4
	ACS3-AFPWSB20	20 (0.5) + 24 (0.2)	20,000 ± 100	787 ± 4
Torsion-Resistant	ACS3-AFPRSB03	20 (0.5) + 24 (0.2)	3,000 ± 50	118 ± 2
	ACS3-AFPRSB05	20 (0.5) + 24 (0.2)	5,000 ± 50	197 ± 2
	ACS3-AFPRSB10	20 (0.5) + 24 (0.2)	10,000 ± 100	394 ± 4
	ACS3-AFPRSB20	20 (0.5) + 24 (0.2)	20,000 ± 100	787 ± 4

Cable exit direction towards encoder

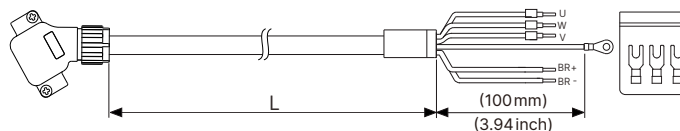

線材	Model Name	UVW	L	
		AWG (mm ²)	mm	inch
Standard	ACS3-ABPWSB03	20 (0.5) + 24 (0.2)	3,000 ± 50	118 ± 2
	ACS3-ABPWSB05	20 (0.5) + 24 (0.2)	5,000 ± 50	197 ± 2
	ACS3-ABPWSB10	20 (0.5) + 24 (0.2)	10,000 ± 100	394 ± 4
	ACS3-ABPWSB20	20 (0.5) + 24 (0.2)	20,000 ± 100	787 ± 4
Torsion-Resistant	ACS3-ABPRSB03	20 (0.5) + 24 (0.2)	3,000 ± 50	118 ± 2
	ACS3-ABPRSB05	20 (0.5) + 24 (0.2)	5,000 ± 50	197 ± 2
	ACS3-ABPRSB10	20 (0.5) + 24 (0.2)	10,000 ± 100	394 ± 4
	ACS3-ABPRSB20	20 (0.5) + 24 (0.2)	20,000 ± 100	787 ± 4

Ordering Information

Accessories

Power Cables

F100 ~ F130

B3 motor, w/o brake, straight connector

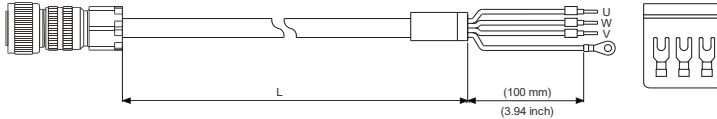

F100 ~ F130

B3 motor, w/o brake, angular connector

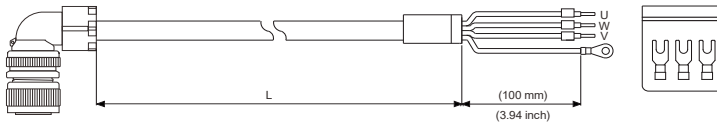

F180, 2/3/4.5 kW

B3 motor, w/o brake, straight connector

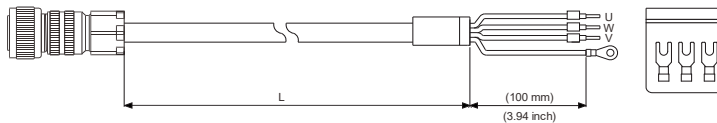

Cable	Model Name	UVW		L	
		AWG (mm ²)	mm	mm	inch
Standard	ACS3-CAPWC303	14 (2.1)	3,000 ± 50	118 ± 2	
	ACS3-CAPWC305	14 (2.1)	5,000 ± 50	197 ± 2	
	ACS3-CAPWC310	14 (2.1)	10,000 ± 100	394 ± 4	
	ACS3-CAPWC320	14 (2.1)	20,000 ± 100	787 ± 4	
	ACS3-CAPWC403	12 (3.3)	3,000 ± 50	118 ± 2	
	ACS3-CAPWC405	12 (3.3)	5,000 ± 50	197 ± 2	
	ACS3-CAPWC410	12 (3.3)	10,000 ± 100	394 ± 4	
	ACS3-CAPWC420	12 (3.3)	20,000 ± 100	787 ± 4	
	ACS3-CAPWC503	10 (5.3)	3,000 ± 50	118 ± 2	
	ACS3-CAPWC505	10 (5.3)	5,000 ± 50	197 ± 2	
	ACS3-CAPWC510	10 (5.3)	10,000 ± 100	394 ± 4	
	ACS3-CAPWC520	10 (5.3)	20,000 ± 100	787 ± 4	
	ACS3-CAPWC603	8 (8.4)	3,000 ± 50	118 ± 2	
	ACS3-CAPWC605	8 (8.4)	5,000 ± 50	197 ± 2	
	ACS3-CAPWC610	8 (8.4)	10,000 ± 100	394 ± 4	
	ACS3-CAPWC620	8 (8.4)	20,000 ± 100	787 ± 4	

Cable	Model Name	UVW		L	
		AWG (mm ²)	mm	mm	inch
Standard	ACS3-CAPWA203	16 (1.3)	3,000 ± 50	118 ± 2	
	ACS3-CAPWA205	16 (1.3)	5,000 ± 50	197 ± 2	
	ACS3-CAPWA210	16 (1.3)	10,000 ± 100	394 ± 4	
	ACS3-CAPWA220	16 (1.3)	20,000 ± 100	787 ± 4	
	ACS3-CAPWA303	14 (2.1)	3,000 ± 50	118 ± 2	
	ACS3-CAPWA305	14 (2.1)	5,000 ± 50	197 ± 2	
	ACS3-CAPWA310	14 (2.1)	10,000 ± 100	394 ± 4	
ACS3-CAPWA320	14 (2.1)	20,000 ± 100	787 ± 4		
Torsion-Resistant	ACS3-CAPFA203	16 (1.3)	3,000 ± 50	118 ± 2	
	ACS3-CAPFA205	16 (1.3)	5,000 ± 50	197 ± 2	
	ACS3-CAPFA210	16 (1.3)	10,000 ± 100	394 ± 4	
	ACS3-CAPFA220	16 (1.3)	20,000 ± 100	787 ± 4	
	ACS3-CAPFA303	14 (2.1)	3,000 ± 50	118 ± 2	
	ACS3-CAPFA305	14 (2.1)	5,000 ± 50	197 ± 2	
	ACS3-CAPFA310	14 (2.1)	10,000 ± 100	394 ± 4	
ACS3-CAPFA320	14 (2.1)	20,000 ± 100	787 ± 4		

Cable	Model Name	UVW		L	
		AWG (mm ²)	mm	mm	inch
Standard	ACS3-CRPWA203	16 (1.3)	3,000 ± 50	118 ± 2	
	ACS3-CRPWA205	16 (1.3)	5,000 ± 50	197 ± 2	
	ACS3-CRPWA210	16 (1.3)	10,000 ± 100	394 ± 4	
	ACS3-CRPWA220	16 (1.3)	20,000 ± 100	787 ± 4	
	ACS3-CRPWA303	14 (2.1)	3,000 ± 50	118 ± 2	
	ACS3-CRPWA305	14 (2.1)	5,000 ± 50	197 ± 2	
	ACS3-CRPWA310	14 (2.1)	10,000 ± 100	394 ± 4	
ACS3-CRPWA320	14 (2.1)	20,000 ± 100	787 ± 4		
Torsion-Resistant	ACS3-CRPFA203	16 (1.3)	3,000 ± 50	118 ± 2	
	ACS3-CRPFA205	16 (1.3)	5,000 ± 50	197 ± 2	
	ACS3-CRPFA210	16 (1.3)	10,000 ± 100	394 ± 4	
	ACS3-CRPFA220	16 (1.3)	20,000 ± 100	787 ± 4	
	ACS3-CRPFA303	14 (2.1)	3,000 ± 50	118 ± 2	
	ACS3-CRPFA305	14 (2.1)	5,000 ± 50	197 ± 2	
	ACS3-CRPFA310	14 (2.1)	10,000 ± 100	394 ± 4	
ACS3-CRPFA320	14 (2.1)	20,000 ± 100	787 ± 4		

Cable	Model Name	UVW		L	
		AWG (mm ²)	mm	mm	inch
Torsion-Resistant	ACS3-CAPFC303	14 (2.1)	3,000 ± 50	118 ± 2	
	ACS3-CAPFC305	14 (2.1)	5,000 ± 50	197 ± 2	
	ACS3-CAPFC310	14 (2.1)	10,000 ± 100	394 ± 4	
	ACS3-CAPFC320	14 (2.1)	20,000 ± 100	787 ± 4	
	ACS3-CAPFC403	12 (3.3)	3,000 ± 50	118 ± 2	
	ACS3-CAPFC405	12 (3.3)	5,000 ± 50	197 ± 2	
	ACS3-CAPFC410	12 (3.3)	10,000 ± 100	394 ± 4	
	ACS3-CAPFC420	12 (3.3)	20,000 ± 100	787 ± 4	
	ACS3-CAPFC503	10 (5.3)	3,000 ± 50	118 ± 2	
	ACS3-CAPFC505	10 (5.3)	5,000 ± 50	197 ± 2	
	ACS3-CAPFC510	10 (5.3)	10,000 ± 100	394 ± 4	
	ACS3-CAPFC520	10 (5.3)	20,000 ± 100	787 ± 4	
	ACS3-CAPFC603	8 (8.4)	3,000 ± 50	118 ± 2	
	ACS3-CAPFC605	8 (8.4)	5,000 ± 50	197 ± 2	
	ACS3-CAPFC610	8 (8.4)	10,000 ± 100	394 ± 4	
	ACS3-CAPFC620	8 (8.4)	20,000 ± 100	787 ± 4	

Ordering Information

Accessories

Power Cables

F180, 2/3/4.5kW

B3 motor, w/o brake, angular connector

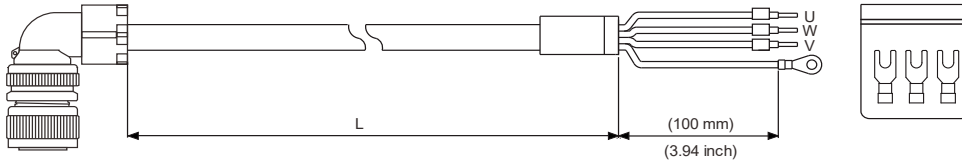

Cable	Model Name	UVW		L	
		AWG (mm ²)	mm	mm	inch
Standard	ACS3-CRPWC303	14 (2.1)	3,000 ± 50	118 ± 2	
	ACS3-CRPWC305	14 (2.1)	5,000 ± 50	197 ± 2	
	ACS3-CRPWC310	14 (2.1)	10,000 ± 100	394 ± 4	
	ACS3-CRPWC320	14 (2.1)	20,000 ± 100	787 ± 4	
	ACS3-CRPWC403	12 (3.3)	3,000 ± 50	118 ± 2	
	ACS3-CRPWC405	12 (3.3)	5,000 ± 50	197 ± 2	
	ACS3-CRPWC410	12 (3.3)	10,000 ± 100	394 ± 4	
	ACS3-CRPWC420	12 (3.3)	20,000 ± 100	787 ± 4	
	ACS3-CRPWC503	10 (5.3)	3,000 ± 50	118 ± 2	
	ACS3-CRPWC505	10 (5.3)	5,000 ± 50	197 ± 2	
	ACS3-CRPWC510	10 (5.3)	10,000 ± 100	394 ± 4	
	ACS3-CRPWC520	10 (5.3)	20,000 ± 100	787 ± 4	
	ACS3-CRPWC603	8 (8.4)	3,000 ± 50	118 ± 2	
	ACS3-CRPWC605	8 (8.4)	5,000 ± 50	197 ± 2	
	ACS3-CRPWC610	8 (8.4)	10,000 ± 100	394 ± 4	
	ACS3-CRPWC620	8 (8.4)	20,000 ± 100	787 ± 4	

Cable	Model Name	UVW		L	
		AWG (mm ²)	mm	mm	inch
Torsion-Resistant	ACS3-CRPFC303	14 (2.1)	3,000 ± 50	118 ± 2	
	ACS3-CRPFC305	14 (2.1)	5,000 ± 50	197 ± 2	
	ACS3-CRPFC310	14 (2.1)	10,000 ± 100	394 ± 4	
	ACS3-CRPFC320	14 (2.1)	20,000 ± 100	787 ± 4	
	ACS3-CRPFC403	12 (3.3)	3,000 ± 50	118 ± 2	
	ACS3-CRPFC405	12 (3.3)	5,000 ± 50	197 ± 2	
	ACS3-CRPFC410	12 (3.3)	10,000 ± 100	394 ± 4	
	ACS3-CRPFC420	12 (3.3)	20,000 ± 100	787 ± 4	
	ACS3-CRPFC503	10 (5.3)	3,000 ± 50	118 ± 2	
	ACS3-CRPFC505	10 (5.3)	5,000 ± 50	197 ± 2	
	ACS3-CRPFC510	10 (5.3)	10,000 ± 100	394 ± 4	
	ACS3-CRPFC520	10 (5.3)	20,000 ± 100	787 ± 4	
	ACS3-CRPFC603	8 (8.4)	3,000 ± 50	118 ± 2	
	ACS3-CRPFC605	8 (8.4)	5,000 ± 50	197 ± 2	
	ACS3-CRPFC610	8 (8.4)	10,000 ± 100	394 ± 4	
	ACS3-CRPFC620	8 (8.4)	20,000 ± 100	787 ± 4	

F180, 5.5 kW and above

B3 motor, w/o brake, straight connector

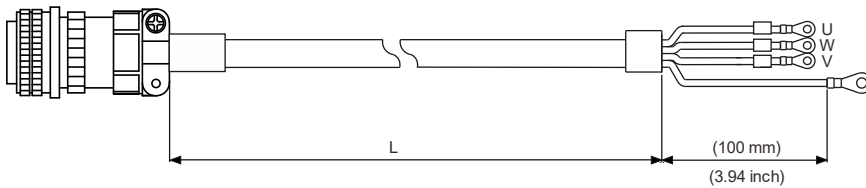

Cable	Model Name	UVW		L	
		AWG (mm ²)	mm	mm	inch
Standard	ACS3-CAPWE603	8 (8.4)	3,000 ± 50	118 ± 2	
	ACS3-CAPWE605	8 (8.4)	5,000 ± 50	197 ± 2	
	ACS3-CAPWE610	8 (8.4)	10,000 ± 100	394 ± 4	
	ACS3-CAPWE620	8 (8.4)	20,000 ± 100	787 ± 4	
	ACS3-CAPWE703	6 (13.3)	3,000 ± 50	118 ± 2	
	ACS3-CAPWE705	6 (13.3)	5,000 ± 50	197 ± 2	
	ACS3-CAPWE710	6 (13.3)	10,000 ± 100	394 ± 4	
	ACS3-CAPWE720	6 (13.3)	20,000 ± 100	787 ± 4	
	ACS3-CAPWE803	4 (21.2)	3,000 ± 50	118 ± 2	
	ACS3-CAPWE805	4 (21.2)	5,000 ± 50	197 ± 2	
	ACS3-CAPWE810	4 (21.2)	10,000 ± 100	394 ± 4	
	ACS3-CAPWE820	4 (21.2)	20,000 ± 100	787 ± 4	

Cable	Model Name	UVW		L	
		AWG (mm ²)	mm	mm	inch
Torsion-Resistant	ACS3-CAPFC303	14 (2.1)	3,000 ± 50	118 ± 2	
	ACS3-CAPFC305	14 (2.1)	5,000 ± 50	197 ± 2	
	ACS3-CAPFC310	14 (2.1)	10,000 ± 100	394 ± 4	
	ACS3-CAPFC320	14 (2.1)	20,000 ± 100	787 ± 4	
	ACS3-CAPFC403	12 (3.3)	3,000 ± 50	118 ± 2	
	ACS3-CAPFC405	12 (3.3)	5,000 ± 50	197 ± 2	
	ACS3-CAPFC410	12 (3.3)	10,000 ± 100	394 ± 4	
	ACS3-CAPFC420	12 (3.3)	20,000 ± 100	787 ± 4	
	ACS3-CAPFC503	10 (5.3)	3,000 ± 50	118 ± 2	
	ACS3-CAPFC505	10 (5.3)	5,000 ± 50	197 ± 2	
	ACS3-CAPFC510	10 (5.3)	10,000 ± 100	394 ± 4	
	ACS3-CAPFC520	10 (5.3)	20,000 ± 100	787 ± 4	

Ordering Information

Accessories

Power Cables

F180, 5.5 kW and above

B3 motor, w/o brake, angular connector

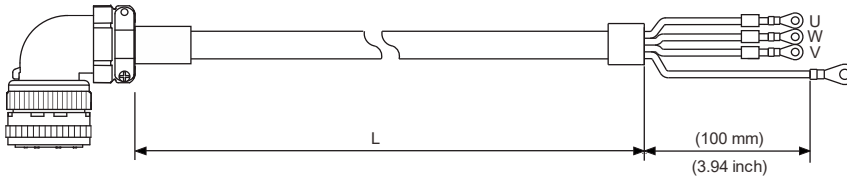

Cable	Model Name	UVW		L	
		AWG (mm ²)	mm	mm	inch
Standard	ACS3-CRPWE603	8 (8.4)	3,000 ± 50	118 ± 2	
	ACS3-CRPWE605	8 (8.4)	5,000 ± 50	197 ± 2	
	ACS3-CRPWE610	8 (8.4)	10,000 ± 100	394 ± 4	
	ACS3-CRPWE620	8 (8.4)	20,000 ± 100	787 ± 4	
	ACS3-CRPWE703	6 (13.3)	3,000 ± 50	118 ± 2	
	ACS3-CRPWE705	6 (13.3)	5,000 ± 50	197 ± 2	
	ACS3-CRPWE710	6 (13.3)	10,000 ± 100	394 ± 4	
	ACS3-CRPWE720	6 (13.3)	20,000 ± 100	787 ± 4	
	ACS3-CRPWE803	4 (21.2)	3,000 ± 50	118 ± 2	
	ACS3-CRPWE805	4 (21.2)	5,000 ± 50	197 ± 2	
	ACS3-CRPWE810	4 (21.2)	10,000 ± 100	394 ± 4	
	ACS3-CRPWE820	4 (21.2)	20,000 ± 100	787 ± 4	

Cable	Model Name	UVW		L	
		AWG (mm ²)	mm	mm	inch
Torsion-Resistant	ACS3-CRPFE603	8 (8.4)	3,000 ± 50	118 ± 2	
	ACS3-CRPFE605	8 (8.4)	5,000 ± 50	197 ± 2	
	ACS3-CRPFE610	8 (8.4)	10,000 ± 100	394 ± 4	
	ACS3-CRPFE620	8 (8.4)	20,000 ± 100	787 ± 4	
	ACS3-CRPFE703	6 (13.3)	3,000 ± 50	118 ± 2	
	ACS3-CRPFE705	6 (13.3)	5,000 ± 50	197 ± 2	
	ACS3-CRPFE710	6 (13.3)	10,000 ± 100	394 ± 4	
	ACS3-CRPFE720	6 (13.3)	20,000 ± 100	787 ± 4	
	ACS3-CRPFE803	4 (21.2)	3,000 ± 50	118 ± 2	
	ACS3-CRPFE805	4 (21.2)	5,000 ± 50	197 ± 2	
	ACS3-CRPFE810	4 (21.2)	10,000 ± 100	394 ± 4	
	ACS3-CRPFE820	4 (21.2)	20,000 ± 100	787 ± 4	

F100 ~ F220 Brake Cable

B3 motor, with brake, straight connector

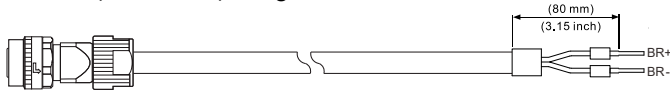

Cable	Model Name	UVW		L	
		AWG (mm ²)	mm	mm	inch
Standard	ACS3-CABRA103	20 (0.5)	3,000 ± 50	118 ± 2	
	ACS3-CABRA105	20 (0.5)	5,000 ± 50	197 ± 2	
	ACS3-CABRA110	20 (0.5)	10,000 ± 100	394 ± 4	
	ACS3-CABRA120	20 (0.5)	20,000 ± 100	787 ± 4	
Torsion-Resistant	ACS3-CABFA103	20 (0.5)	3,000 ± 50	118 ± 2	
	ACS3-CABFA105	20 (0.5)	5,000 ± 50	197 ± 2	
	ACS3-CABFA110	20 (0.5)	10,000 ± 100	394 ± 4	
	ACS3-CABFA120	20 (0.5)	20,000 ± 100	787 ± 4	

F100 ~ F220 Brake Cable

B3 motor, with brake, angular connector

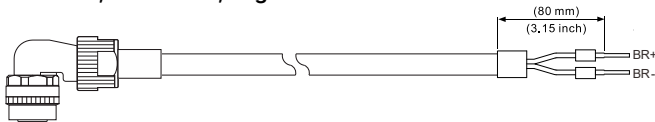

Cable	Model Name	UVW		L	
		AWG (mm ²)	mm	mm	inch
Standard	ACS3-CRBRA103	20 (0.5)	3,000 ± 50	118 ± 2	
	ACS3-CRBRA105	20 (0.5)	5,000 ± 50	197 ± 2	
	ACS3-CRBRA110	20 (0.5)	10,000 ± 100	394 ± 4	
	ACS3-CRBRA120	20 (0.5)	20,000 ± 100	787 ± 4	
Torsion-Resistant	ACS3-CRBFA103	20 (0.5)	3,000 ± 50	118 ± 2	
	ACS3-CRBFA105	20 (0.5)	5,000 ± 50	197 ± 2	
	ACS3-CRBFA110	20 (0.5)	10,000 ± 100	394 ± 4	
	ACS3-CRBFA120	20 (0.5)	20,000 ± 100	787 ± 4	

Encoder Connectors

ACS3-CAENA000
(F100 ~ F180)
Mil-Spec: CM V1-SP10S

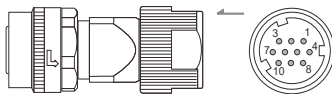

ACS3-CNENC200
(connecting to drive)

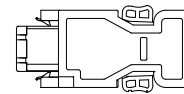

ACS3-CRENA000
(F100 ~ F180)
Mil-Spec: CM V1-AP10S

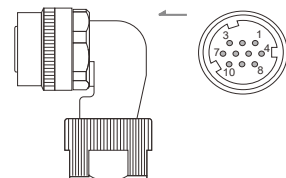

Ordering Information

Accessories

Encoder Cable (Battery-Less / Incremental)

Cable exit direction towards motor shaft

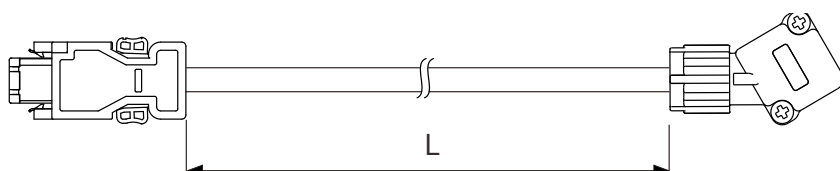

Cable	Model Name	L	
		mm	inch
Standard	ACS3-AFEASI03	3,000 ± 50	118 ± 2
	ACS3-AFEASI50	5,000 ± 50	197 ± 2
	ACS3-AFEASI10	10,000 ± 50	394 ± 4
	ACS3-AFEASI202	20,000 ± 50	787 ± 4
Torsion-Resistant	ACS3-AFERSI030	3,000 ± 50	118 ± 2
	ACS3-AFERSI05	5,000 ± 50	197 ± 2
	ACS3-AFERSI101	10,000 ± 50	394 ± 4
	ACS3-AFERSI202	20,000 ± 50	787 ± 4

Cable exit direction towards encoder

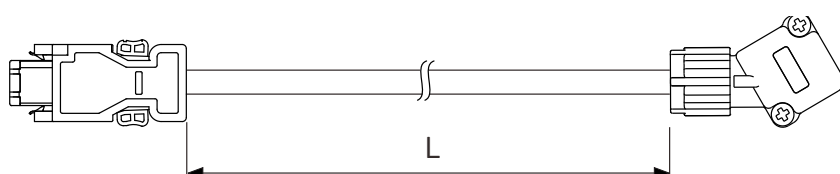

Cable	Model Name	L	
		mm	inch
Standard	ACS3-ABEASI030	3,000 ± 50	118 ± 2
	ACS3-ABEASI050	5,000 ± 50	197 ± 2
	ACS3-ABEASI101	10,000 ± 50	394 ± 4
	ACS3-ABEASI202	20,000 ± 50	787 ± 4
Torsion-Resistant	ACS3-ABERSI030	3,000 ± 50	118 ± 2
	ACS3-ABERSI050	5,000 ± 50	197 ± 2
	ACS3-ABERSI101	10,000 ± 50	394 ± 4
	ACS3-ABERSI202	20,000 ± 50	787 ± 4

Encoder Cable (Incremental)

F100 ~ F180

B3 motor, straight connector

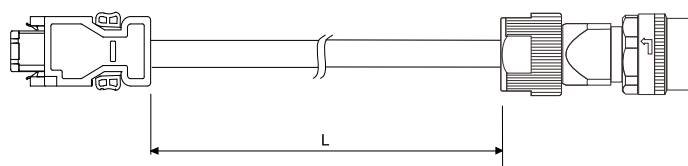

Cable	Model Name	L	
		mm	inch
Standard	ACS3-CAENA103	3,000 ± 50	118 ± 2
	ACS3-CAENA105	5,000 ± 50	197 ± 2
	ACS3-CAENA110	10,000 ± 100	394 ± 4
	ACS3-CAENA120	20,000 ± 100	787 ± 4
Torsion-Resistant	ACS3-CAEFA103	3,000 ± 50	118 ± 2
	ACS3-CAEFA105	5,000 ± 50	197 ± 2
	ACS3-CAEFA110	10,000 ± 100	394 ± 4
	ACS3-CAEFA120	20,000 ± 100	787 ± 4

F100 ~ F180

AA3/B3 Motor, angular connector

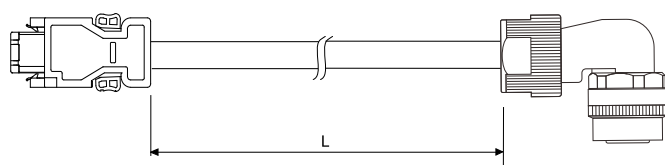

Cable	Model Name	L	
		mm	inch
Standard	ACS3-CRENA103	3,000 ± 50	118 ± 2
	ACS3-CRENA105	5,000 ± 50	197 ± 2
	ACS3-CRENA110	10,000 ± 100	394 ± 4
	ACS3-CRENA120	20,000 ± 100	787 ± 4
Torsion-Resistant	ACS3-CREFA103	3,000 ± 50	118 ± 2
	ACS3-CREFA105	5,000 ± 50	197 ± 2
	ACS3-CREFA110	10,000 ± 100	394 ± 4
	ACS3-CREFA120	20,000 ± 100	787 ± 4

Ordering Information

Accessories

Encoder Cable (Incremental)

Cable exit direction towards motor shaft

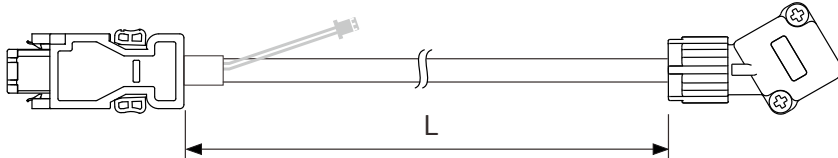

Cable	Model Name	L	
		mm	inch
Standard	ACS3-AFEESA03	3,000 ± 50	118 ± 2
	ACS3-AFEESA050	5,000 ± 50	197 ± 2
	ACS3-AFEESA10	10,000 ± 50	394 ± 4
	ACS3-AFEESA202	20,000 ± 50	787 ± 4
Torsion-Resistant	ACS3-AFERSA030	3,000 ± 50	118 ± 2
	ACS3-AFERSA05	5,000 ± 50	197 ± 2
	ACS3-AFERSA10	10,000 ± 50	394 ± 4
	ACS3-AFERSA202	20,000 ± 50	787 ± 4

Cable exit direction towards encoder

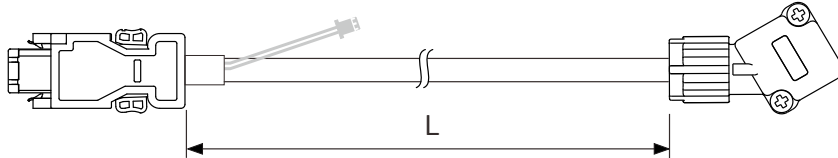

Cable	Model Name	L	
		mm	inch
Standard	ACS3-ABEESA030	3,000 ± 50	118 ± 2
	ACS3-ABEESA050	5,000 ± 50	197 ± 2
	ACS3-ABEESA101	10,000 ± 50	394 ± 4
	ACS3-ABEESA202	20,000 ± 50	787 ± 4
Torsion-Resistant	ACS3-ABERSA030	3,000 ± 50	118 ± 2
	ACS3-ABERSA050	5,000 ± 50	197 ± 2
	ACS3-ABERSA101	10,000 ± 50	394 ± 4
	ACS3-ABERSA202	20,000 ± 50	787 ± 4

Encoder Cable (Absolute)

F100 ~ F180

A3/B3 Motor, straight connector

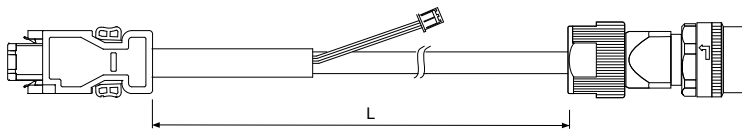

Cable	Model Name	L	
		mm	inch
Standard	ACS3-CAEAA103	3,000 ± 50	118 ± 2
	ACS3-CAEAA105	5,000 ± 50	197 ± 2
	ACS3-CAEAA110	10,000 ± 100	394 ± 4
	ACS3-CAEAA120	20,000 ± 100	787 ± 4
Torsion-Resistant	ACS3-CAEBA103	3,000 ± 50	118 ± 2
	ACS3-CAEBA105	5,000 ± 50	197 ± 2
	ACS3-CAEBA110	10,000 ± 100	394 ± 4
	ACS3-CAEBA120	20,000 ± 100	787 ± 4

F100 ~ F180

A3/B3 Motor, angular connector

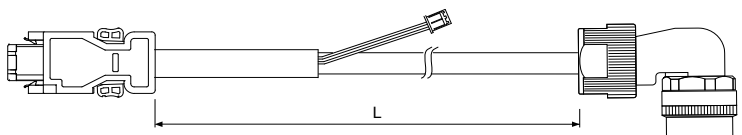

Cable	Model Name	L	
		mm	inch
Standard	ACS3-CREAA103	3,000 ± 50	118 ± 2
	ACS3-CREAA105	5,000 ± 50	197 ± 2
	ACS3-CREAA110	10,000 ± 100	394 ± 4
	ACS3-CREAA120	20,000 ± 100	787 ± 4
Torsion-Resistant	ACS3-CREBA103	3,000 ± 50	118 ± 2
	ACS3-CREBA105	5,000 ± 50	197 ± 2
	ACS3-CREBA110	10,000 ± 100	394 ± 4
	ACS3-CREBA120	20,000 ± 100	787 ± 4

Ordering Information

Accessories

Absolute Battery Box

**Single Battery Box
ASD-MDBT0100**

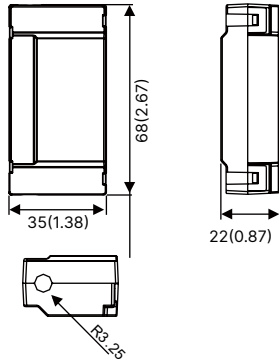

**Double Battery Box
ASD-MDBT0200**

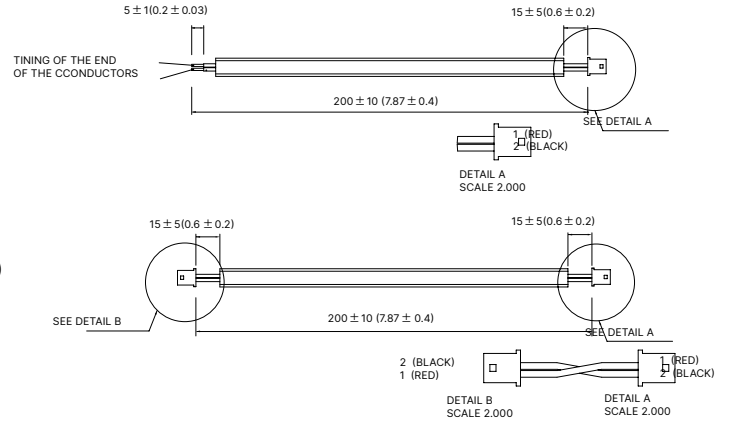
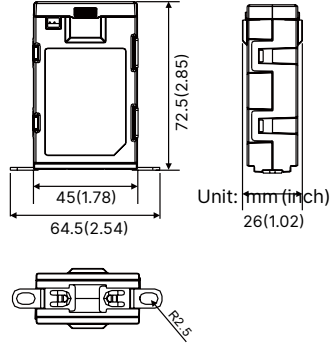

Note: Contact Delta Global Service team if ordering battery box cord only

Ordering Information

A3-EP Accessory

Item	P/N	Picture
D	3050605646	
E	3479065500	
F	3050027000	
G	3050606846	

Item	P/N	Picture
H	3050609246	
I	3050611946	
J	3050609346	

Servo Drive Standards

Standard	ASD-A3-EP servo drive conforms to the highest standards and recommendations for electrical industrial control equipment (IEC, EN)
EMC Immunity	EN61000-4-6 Level 3
	EN61000-4-3 Level 3
	EN61000-4-2 Level 2 & 3
	EN61000-4-4 Level 3
	EN61000-4-8 Level 4
	EN61000-4-5 Level 3
Conducted and Radiated EMC Interference of Servo Driv	EN61800-3 Level 3, with external EMC filter
CE Marking	Servo Drive with CE marking and conform to the European Union Low Voltage Directive (2014/35/EU) and EMC Directive (2014/30/EU)
Product Certification	UL (USA) , KC (Korea) , cUL (Canada)
STO	EN 61800-5-2:2007
	EN 61800-5-2:2017
	EN 61800-5-1:2007 + A1:2017, 4.3, 5.2.3.8, 5.2.6
	EN IEC 61800-3:2018
	EN 62061:2005 + AC:2010 + A1:2013 + A2:2015
	EN ISO 13849-1:2015
	EN 61508 Parts 1-7:2010
Product Certification	IEC/EN50178 , IP20
Vibration Resistance Protection	20 Hz and below (1G), 20 ~ 50Hz (0.6 G) conforms to IEC/EN50178
Shock Resistance Protection	15 gn 11 ms conforms to IEC/EN600028-2-27
Pollution Degree	Degree 2 conforms to IEC/EN61800-5-1
CE	EN 60034-1
Certification	UL, CE, cRUus
Protection Level	IP67
Vibration Resistance Protection	30 Hz ≤ f ≤ 2,000Hz Fix Acceleration: 5 G
Energy Efficiency Certification	CHINA ENERGY (Power > 550 W)
Safety Card	IEC 61800-5-2/IEC 61508 /IEC 62061/ISO 13849-1/IEC 61800-5-2



Smarter. Greener. Together.

Industrial Automation Headquarters

Taiwan: Delta Electronics, Inc.

Taoyuan Technology Center
No.18, Xinglong Rd., Taoyuan District,
Taoyuan City 330477, Taiwan
TEL: +886-3-362-6301 / FAX: +886-3-371-6301

Asia

China: Delta Electronics (Shanghai) Co., Ltd.

No.182 Minyu Rd., Pudong Shanghai, P.R.C.
Post code : 201209
TEL: +86-21-6872-3988 / FAX: +86-21-6872-3996
Customer Service: 400-820-9595

Japan: Delta Electronics (Japan), Inc.

Industrial Automation Sales Department
4-11-25, Shibaura, Minato-ku, Tokyo 108-0023, Japan
TEL: +81-3-6811-5470 / FAX: +81-3-6811-5802

Korea: Delta Electronics (Korea), Inc.

1511, 219, Gasan Digital 1-Ro., Geumcheon-gu,
Seoul, 08501 South Korea
TEL: +82-2-515-5305 / FAX: +82-2-515-5302

Singapore: Delta Energy Systems (Singapore) Pte Ltd.

4 Kaki Bukit Avenue 1, #05-04, Singapore 417939
TEL: +65-6747-5155 / FAX: +65-6744-9228

India: Delta Electronics (India) Pvt. Ltd.

Plot No.43, Sector 35, HSIIDC Gurgaon,
PIN 122001, Haryana, India
TEL: +91-124-4874900 / FAX: +91-124-4874945

Thailand: Delta Electronics (Thailand) PCL.

909 Soi 9, Moo 4, Bangpoo Industrial Estate (E.P.Z),
Pattana 1 Rd., T.Phraksa, A.Muang,
Samutprakarn 10280, Thailand
TEL: +66-2709-2800 / FAX: +66-2709-2827

Australia: Delta Electronics (Australia) Pty Ltd.

Unit 2, Building A, 18-24 Ricketts Road,
Mount Waverley, Victoria 3149 Australia
Mail: IA.au@deltaww.com
TEL: +61-1300-335-823 / +61-3-9543-3720

Americas

USA: Delta Electronics (Americas) Ltd.

5101 Davis Drive, Research Triangle Park, NC 27709, U.S.A.
TEL: +1-919-767-3813

Brazil: Delta Electronics Brazil Ltd.

Estrada Velha Rio-São Paulo, 5300 Eugênio de
Melo - São José dos Campos CEP: 12247-004 - SP - Brazil
TEL: +55-12-3932-2300 / FAX: +55-12-3932-237

Mexico: Delta Electronics International Mexico S.A. de C.V.

Gustavo Baz No. 309 Edificio E PB 103
Colonia La Loma, CP 54060
Tlalnepantla, Estado de México
TEL: +52-55-3603-9200

EMEA

EMEA Headquarters: Delta Electronics (Netherlands) B.V.

Sales: Sales.IA.EMEA@deltaww.com
Marketing: Marketing.IA.EMEA@deltaww.com
Technical Support: iatechnicalsupport@deltaww.com
Customer Support: Customer-Support@deltaww.com
Service: Service.IA.emea@deltaww.com
TEL: +31(0)40 800 3900

BENELUX: Delta Electronics (Netherlands) B.V.

Automotive Campus 260, 5708 JZ Helmond, The Netherlands
Mail: Sales.IA.Benelux@deltaww.com
TEL: +31(0)40 800 3900

DACH: Delta Electronics (Netherlands) B.V.

Coesterweg 45, D-59494 Soest, Germany
Mail: Sales.IA.DACH@deltaww.com
TEL: +49 2921 987 238

France: Delta Electronics (France) S.A.

ZI du bois Challand 2, 15 rue des Pyrénées,
Lisses, 91090 Evry Cedex, France
Mail: Sales.IA.FR@deltaww.com
TEL: +33(0)1 69 77 82 60

Iberia: Delta Electronics Solutions (Spain) S.L.U

Ctra. De Villaverde a Vallecas, 265 1º Dcha Ed.
Hormigueras – P.I. de Vallecas 28031 Madrid
TEL: +34(0)91 223 74 20
Carrer Llacuna 166, 08018 Barcelona, Spain
Mail: Sales.IA.Iberia@deltaww.com

Italy: Delta Electronics (Italy) S.r.l.

Via Meda 2-22060 Novedrate(CO)
Piazza Grazioli 18 00186 Roma Italy
Mail: Sales.IA.Italy@deltaww.com
TEL: +39 039 8900365

Turkey: Delta Greentech Elektronik San. Ltd. Sti. (Turkey)

Şerifali Mah. Hendem Cad. Kule Sok. No:16-A
34775 Ümraniye – İstanbul
Mail: Sales.IA.Turkey@deltaww.com
TEL: + 90 216 499 9910

MEA: Eltek Dubai (Eltek MEA DMCC)

OFFICE 2504, 25th Floor, Saba Tower 1,
Jumeirah Lakes Towers, Dubai, UAE
Mail: Sales.IA.MEA@deltaww.com
TEL: +971(0)4 2690148